

Module 4: Weights and Dimensions

Commercial Vehicle Safety Compliance
in Alberta

Module 4: Weights and Dimensions aims to provide carriers with basic information about vehicle weights and dimensions. The contents of this module include information about:

Contents

VEHICLE WEIGHTS AND DIMENSIONS.....	1
• Legal Weights	1
• Signs on Vehicles	2
• Maximum Dimensions	3
PERMITS	4
• Conditions	4
OVER-DIMENSIONAL SAFETY REQUIREMENTS	5
ESCORT VEHICLE REQUIREMENTS	6
• Travel Requirements	6
• Equipment Requirements	6
GETTING PERMITS IN ALBERTA: ONLINE SERVICES	7
• Obtaining Permits	7
• TRAVIS Multi-Jurisdiction	8
• Third Party Agencies	8
ROAD RESTRICTIONS AND ROAD BANS.....	9
• Long Combination Vehicle (LCV) Permits and Routes	9
• High Vehicle Permits and Routes	9
RESOURCES FOR CARRIERS	9

This module serves only as a guide and cannot replace regulatory legislation.

However, every effort has been made to ensure the information in this module is accurate at the time of preparation. The material in these documents are not intended to represent a full training course in any subject area covered, nor is it intended to be reproduced or sold for commercial purposes or financial gain.

VEHICLE WEIGHTS AND DIMENSIONS

Legal Weights

Provinces and territories have laws that establish maximum vehicle weights. This is to ensure public safety and to protect Alberta's highway infrastructure. A carrier must comply with all weight restrictions for the roads they operate on. In Alberta, legal weights depend on different things such as the type of vehicle, the number of axles on the vehicle, the manufacturer's rating and the size of the tires on the vehicle.

A quick reference guide to Alberta's weight regulations for common vehicles and equipment is available online at: www.alberta.ca/weight-and-dimensions-regulations.aspx.

Carriers must be aware of weight restrictions that may apply to their vehicles. There is a calculator available on the website (www.transportation.alberta.ca/4779.htm) mentioned above which may help a carrier determine whether their vehicles meet the maximum allowable weight according to Alberta laws.

Example of online allowable vehicle weight calculator:

Maximum Allowable Weight for Tractor Semi-trailer

Feb. 23, 2022

Interaxle spacing: 5.5 m

Max. combined weight: []

Percentage axle limit: 100 %

Axle Group	Number of axles	Tridem Axle Spread	Number of tires	Tire size	Rated tire capacity	Allowable axle weight	Notes
Steering	1		2	11 in.	2750		
Drives	2	2.4-2.80 m	8	235 mm.	2200		
Trailer	3	3.0-3.10 m	12	235 mm.	2200		

Maximum Allowable Gross Weight: []

Maximum registered weight: []

Calculate Weight [Reset]

1. This function calculates the maximum allowable weights as per the Commercial Vehicle Dimension and Weight Regulation of the Traffic Safety Act. Where the information shown on this page is not in agreement with the regulation, the regulation shall prevail.
2. This function **does not** take into consideration the "gross axle weight rating" (GAWR) or the "gross vehicle weight rating" (GVWR) of the vehicle. The owner/operator of the vehicle should ensure that the weight carried is within the manufacturer's rated capacity specifications.
3. The "Rated Tire Capacity" is the rated capacity of one tire, based on either single or dual application, as stamped on the sidewall of the tire.
4. The steering axle weight for a truck tractor is capped at 6,000 kg.
5. When the interaxle spacing is less than the minimum specified in regulations, the combined axle weight for the combination is reduced by 500 kg for every 0.1 metre or portion thereof. This will also reduce the allowable GVW.

Signs on Vehicles

Once a carrier has calculated the weight of their vehicle, they must place signs on it.

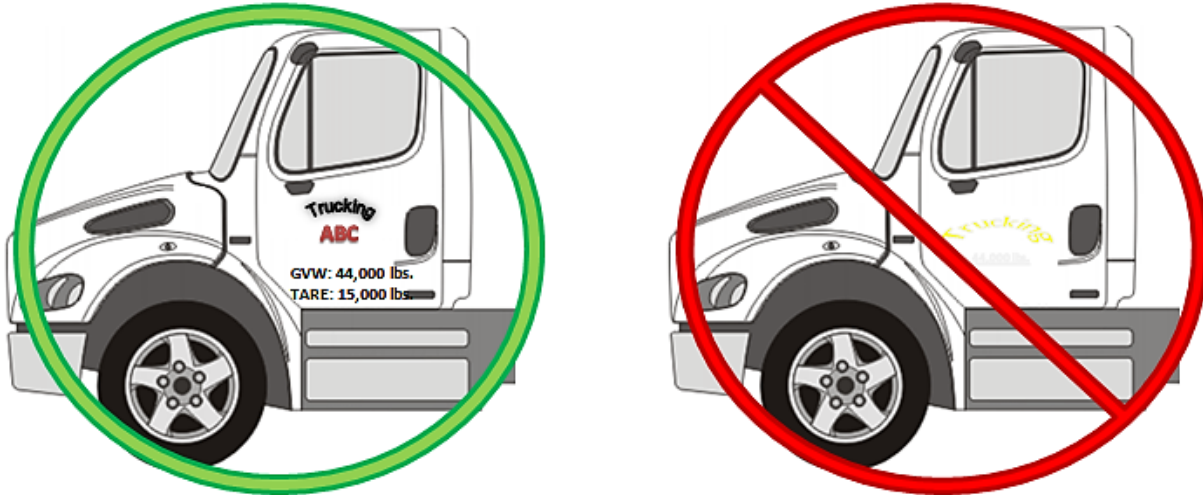

According to Schedule 1, Section 9 of the [Commercial Vehicle Safety Regulation \(AR121/2009\)](#), commercial vehicles that are weighing or registered for more than 4,500 kilograms must have the following information displayed on the left and right sides of the vehicle:

- The name or registered logo of the vehicle's owner;
- The vehicle's TARE weight;
- The licensed maximum gross weight of the vehicle (GVW).

The TARE weight of a vehicle means the weight of the vehicle when it is empty or not carrying cargo. The GVW of a vehicle means the licensed maximum weight of the vehicle as per the vehicle's certificate of registration.

The letters and numbers listed on the side of a vehicle must be at least 50 millimeters in height. They must also be a different color from their background so that the information is clearly visible. All information listed on the vehicle must be accurate.

A commercial vehicle must not be operated on a highway unless the owner of the registered vehicle has correctly decalated the sides of it.

Some exemptions do apply. Refer to the [Commercial Vehicle Safety Regulation \(AR121/2009\)](#) for details.



Maximum Dimensions

A carrier must also be aware of the actual size of their vehicle and load as maximum dimensions apply. If a vehicle or its load is too tall or too wide, it may not be able to travel on certain routes because of the heights of bridges and the width of roads.

A quick reference guide to Alberta's dimension limits for common vehicles and equipment is available online at: www.alberta.ca/weight-and-dimensions-regulations.aspx

Summarized, the maximum dimensions of common commercial vehicles in Alberta are as follows:

Width: 2.6 metres (8' 6")

Height: 4.15 metres (13' 6")

Length: Single Vehicle	12.5 metres (41' 0")
Truck-Tractor and Semi-Trailer	23.0 metres (75' 6")
Truck in Combination, Truck and Pony Trailer, Truck and Full Trailer	23.0 metres (75' 6")
Truck-Tractor, Semi-Trailer and Full Trailer or Semi-Trailer in Combination	26.0 metres (85' 3")

Part 1 - Dimension Limits

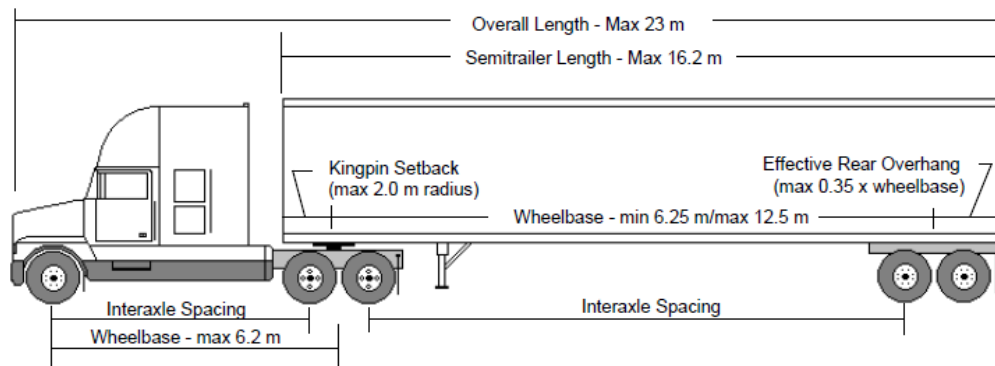

Provincial laws related to legal weights and dimensions in the trucking industry are available in paper and electronic format through the Alberta Queen's Printer Bookstore that is available online at: www.qp.alberta.ca/570.cfm.

Carriers may be eligible to obtain permits for the movement of vehicles or loads that exceed the maximum dimensions or maximum legal weights.

PERMITS

Vehicles that exceed the maximum allowable weights or dimensions may be allowed to operate if a carrier gets a permit. The Alberta government monitors, controls and issues permits for the movement of all overweight or over-dimensional commercial vehicles. This is done for the following reasons:

- To ensure the safety of the traveling public;
- To minimize the inconvenience to the traveling public;
- To protect Alberta's infrastructure (roads and bridges);
- To assist in the movement of items that cannot be divided or are not economical to transport at legal dimensions; and
- To establish and communicate to the carrier a set of conditions for the safe movement of a load.



Conditions

Conditions are applied to permits to enhance public safety. They often include things such as adding extra signage to vehicles which have exceeded the weights and dimensions in regulations. A summary of conditions may be found on the next page.

Carriers who are issued a permit must ensure they and their drivers read and follow all applicable conditions.

OVER-DIMENSIONAL SAFETY REQUIREMENTS

When a carrier operates a commercial vehicle under the authority of an over-dimensional permit, they must meet all relevant safety requirements in Part 4 of the Alberta [Commercial Vehicle Dimension and Weight Regulation \(AR 315/2002\)](#):

VEHICLE OR OPERATION TYPE	SAFETY FITNESS CERTIFICATE REQUIRED
Over 2.60 metres wide (8' 6")	<ul style="list-style-type: none"> • Vehicle equipped with flags by day; and • Vehicle equipped with warning lights by night or during adverse weather conditions.
Over 3.05 metres wide (10')	<ul style="list-style-type: none"> • As above <u>and</u> 2 dimension signs at the front and back of the vehicle in a manner that is clearly visible to approaching traffic.
Over 3.35 metres wide (11')	<ul style="list-style-type: none"> • As above <u>and</u> 1 or more flashing lights.
Over 3.85 metres wide (12' 6")	<ul style="list-style-type: none"> • As above and 1 pilot vehicle behind when on 4-lane road or 1 pilot vehicle in front when on 2-lane road; • No movement from 3:00pm until midnight on a Friday or a day preceding a statutory holiday; and • No movement on a Sunday or a statutory holiday.
Over 4.45 metres wide (14' 7")	<ul style="list-style-type: none"> • Vehicle equipped with flags, signs, and flashing lights; • On 2-lane road, need 1 pilot and 1 trailing vehicle; • On 4-lane road, vehicles up to 5.5m wide (18') need 1 trailing vehicle; • On 4-lane road, vehicles over 5.5m wide need 1 pilot and 1 trailing vehicle; • No operation on highway from 3:00pm until midnight on a Friday or a day preceding a statutory holiday; • No operation on highway on Sunday or a statutory holiday; and • Travel during DAYLIGHT HOURS ONLY.
Over 5.5 metres wide (18')	<ul style="list-style-type: none"> • As above <u>and</u> other conditions as specified on the permit; • Stopping on provincial highways only permitted at designated truck pull-outs (except for emergencies and power line lifting); and • Travel during DAYLIGHT HOURS ONLY.
Over 5.3 metres high (17' 4")	<ul style="list-style-type: none"> • Notify power and telephone companies; and • Travel during DAYLIGHT HOURS ONLY.

In addition to these requirements, carriers must also follow all conditions that are listed on their over-dimensional permit.

ESCORT VEHICLE REQUIREMENTS

According to Part 4 of the Alberta [Commercial Vehicle Dimension and Weight Regulation \(AR 315/2002\)](#), when an over-dimensional vehicle must be accompanied by an escort vehicle, the following requirements must be met:

Travel Requirements

- 2-way radio communication between the escort vehicle and the over-dimensional vehicle must be maintained at all times;
- A pilot vehicle accompanying an over-dimensional vehicle must precede it at a distance of 300 to 1000 metres;
- A trail vehicle accompanying an over-dimensional vehicle must follow it at a distance of 100 to 300 metres;
- The escort vehicle must not tow any trailer or other vehicle, or carry a load that obscures any equipment the vehicle is required to have.



Equipment Requirements

- Escort vehicles must be equipped with a dimensional sign (as shown in Schedules 4 and 5 of the regulation) that is visible from both the front and rear of the vehicle;
- An escort vehicle must carry at least the following equipment:
 - 3 approved warning devices;
 - 3 warning flags for traffic marking;
 - 1 warning flag per crew member for flagging;
 - One reflective vest per crew member; and
 - One flashlight per crew member.

For the full requirements, refer to Part 4 of the Alberta [Commercial Vehicle Dimension and Weight Regulation \(AR 315/2002\)](#) and the [Escort Vehicle Operator's Handbook](#).

GETTING PERMITS IN ALBERTA: ONLINE SERVICES

The Alberta government has an online system that allows carriers to quickly and easily apply for permits. Carriers may also check the status of applications and permits which they have already sent in.

Once a carrier has registered for Alberta Transportation Online Services, they will be able to access the website at www.trans.gov.ab.ca/TravisWebLogin/redirect.htm using their Log-in information.

The screenshot shows the 'Government of Alberta Transportation' website. The main heading is 'Online Services'. On the left is a sidebar with links: Mobile Access, Login, Minimum Requirements, FAQ, Copyright & Disclaimer, Security and Privacy, Trouble-Shooting, TRAVIS Agencies, and Application User Guides. The main content area is titled 'Alberta Transportation Online Services' and shows 'Version: Primary Version - 64Bit'. A 'Login To System' box contains fields for 'User ID' and 'Password' with a 'Submit' button. Below the login box are links for 'Need a User ID? Register', 'Forgot Your Password? Reset Password Help', and 'Forgot Your User ID? Send User Info Help'. A red announcement states: '**Month-end data for December 2021 is now available, including industry average data.**' and 'As of December 1, 2020 impaired driving contraventions are available on profiles.' Another red note says: 'It may take 5 to 30+ minutes for profiles to generate and send by email due to current volumes. Month-end data is scheduled to run on the first Saturday of the month for the previous month's data.'

More information about Alberta Transportation Online Services is available online at: www.trans.gov.ab.ca/TravisWebLogin/redirect.htm

Obtaining Permits

Carriers may apply for the following permits:

WEB ENABLED PERMITS (Applications must be sent over the internet, either by a carrier or through a third party agency)	NON-WEB ENABLED PERMITS (Applications must be sent to the <u>Central Permit Office</u> , either by a carrier or through a third party agency)
<ol style="list-style-type: none"> 1. Single trip overweight 2. Drilling rig overweight 3. Multi-trip overweight 4. Single trip overdimension 5. Multi trip overdimension 6. Seasonal log haul dimensional 7. Salvage log haul dimensional 8. Single trip licensing 9. 30/60/90 day licensing 10. Winter log haul 	<ol style="list-style-type: none"> 1. Equipment exemption 2. Road ban exemption 3. Log haul permits (specialized configurations) 4. Resource Road Log Haul 5. Annual steering axle overloads 6. Public entertainment vehicle

TRAVIS Multi-Jurisdiction

A permit system called TRAVIS Multi-Jurisdiction (TRAVIS-MJ) was developed as part of Alberta Transportation's Online Services to simplify permit applications for carriers who operate in more than one jurisdiction. In the past, carriers had to obtain provincial permits as well as permits from each local road authority.

TRAVIS-MJ allows carriers to apply for and more quickly obtain permits that cover **both** provincial highways and local roads of participating municipalities that oversize loads travel on. Rather than having to carry multiple documents, carriers are issued a single document with all required permit approvals and conditions.

More information about TRAVIS-MJ is available online at: www.trans.gov.ab.ca/TravisWebLogin/welcome.htm

Third Party Agencies

Third party agencies may assist carriers with their permit applications for a fee. These agencies can put all permit application data into Online Services for the carrier. More information on using approved third party agencies is available online at: www.trans.gov.ab.ca/TravisWebLogin/welcome.htm

For more information on obtaining permits, contact the Alberta Transportation Central Permit Office or visit www.alberta.ca/commercial-vehicle-weight-and-dimension-permits.aspx.

Business Hours

7:00am – 9:00pm Monday to Friday

8:15am – 4:00pm Saturday, Sunday and Statutory Holidays

Toll Free 800-662-7138

Local 403-342-7138

Email central.permits@gov.ab.ca

ROAD RESTRICTIONS AND ROAD BANS

Sometimes the roads in Alberta are restricted because of:

- Construction and road maintenance;
- Seasonal conditions such as spring thaw;
- Dimensional restrictions (due to overhead structures and bridges);
- Weight restrictions (due to the maximum weights that bridges or other structures are capable of holding).

Carriers should always be aware that road restrictions or bans may change, which may result in the carrier having to change their route.

Information about these restrictions is available on the Alberta Transportation website at: www.alberta.ca/road-restrictions-and-bans-overview.aspx



Long Combination Vehicle (LCV) Permits and Routes

Section 62 of the *Traffic Safety Act* gives the Registrar authority to issue permits to carriers so they may operate Long Combination Vehicles (LCV). A Long Combination Vehicle is a truck tractor with two or three trailers. The number of trailers in the combination or the combined length of the truck and trailers exceed legal dimensions (26 metres in length for A and C trains, 27.5 metres for B trains).



Applications for permits allowing the operation of an LCV and the conditions of those permits are available on the Alberta Transportation web site at: www.alberta.ca/long-combination-vehicle-program.aspx.

High Vehicle Permits and Routes

The High Load Corridor is a set of highways within the Province of Alberta which accommodate extremely high or wide loads. Permits for moving such loads through this corridor are required from the Alberta government.

A map of the corridor and the fees are available on the Alberta Transportation web site at: www.alberta.ca/high-load-corridor.aspx

RESOURCES FOR CARRIERS

For a better understanding as to how weights and dimensions regulations affect their operations, carriers may wish to refer to these resources for more information.

Commercial Vehicle Dimension and Weight Regulation (AR 315/2002)
www.qp.alberta.ca/1266.cfm?page=2002_315.cfm&leg_type=Regs&isbncln=9780779775439

Alberta Transportation: Weights and Dimensions Regulations
www.alberta.ca/weight-and-dimensions-regulations.aspx