

**ALBERTA TRANSPORTATION SPRINGBANK OFF-STREAM RESERVOIR PROJECT
RESPONSE TO NRCB AND AEP SUPPLEMENTAL INFORMATION REQUEST 1, JULY 28, 2018**

Appendix IR14-5 Dam Alignment and Toe Location Relative to the Elbow River of the Springbank Off Stream Reservoir Project
May 2019

**APPENDIX IR14-5 DAM ALIGNMENT AND TOE LOCATION
RELATIVE TO THE ELBOW RIVER OF THE
SPRINGBANK OFF STREAM RESERVOIR
PROJECT**

**ALBERTA TRANSPORTATION SPRINGBANK OFF-STREAM RESERVOIR PROJECT
RESPONSE TO NRCB AND AEP SUPPLEMENTAL INFORMATION REQUEST 1, JULY 28, 2018**

Appendix IR14-5 Dam Alignment and Toe Location Relative to the Elbow River of the Springbank Off Stream Reservoir Project
May 2019

To: Syed Abbas
Alberta Transportation

From: Hugo Aparicio, PE
Scott Peyton, PE
Stantec

File: 110773396

Date: July 22, 2016

Reference: Dam Alignment and Toe Location Relative to the Elbow River

INTRODUCTION

This memorandum includes considerations, discussion, and recommendations regarding the location of the Springbank Off-stream Storage Dam relative to the Elbow River. It is being offered as additional information, following initial site access, in response to Review Board Meeting Number 2, Comment Number 3 (below).

- 3. RB:** *The Board recommends that the benefits, design implications, and costs of moving the SR1 Dam further downstream, resulting in a possible lowering of the reservoir storage levels or, alternatively, providing additional storage, be further investigated, with due regard to the safety of the SR1 Dam toe under extreme flood conditions in the Elbow River.*

Stantec's design team focused on this issue in the first 60 days following site access to the dam site in April and May 2016. It should be noted that some important boring locations have still not been drilled. However, we have advanced our assessment of the risks relative to the dam proximity to the river sufficiently to make a recommendation on the location of the dam toe as we move into the preliminary design phase.

BACKGROUND

The initial design concept (IDC) was developed by others and documented in the June 2014 report, "Flood Mitigation Measures for the Bow River, Elbow River and Oldman River Basins" (AMEC, 2014). The IDC included provision of 41,200 dam³ of flood storage for protection up to the 1% annual exceedance probability (AEP) flood event. The storage dam had a crest elevation of 1212.0 m, maximum reservoir flood level at elevation 1210.5 m and storage volume of 57,000 dam³. The dam toe of the IDC was approximately 300 m away from the top of bank of the Elbow River at its closest location.

In April 2015, Stantec submitted the Conceptual Design Update Memorandum (Stantec, 2015). The conceptual design included provision of 70,200 dam³ of storage for flood mitigation up to the 2013 flood event. This storage requirement, along with an accounting of sedimentation and additional local watershed inflow produced a pool elevation of 1210.3 m. The resulting embankment dam had a crest elevation of 1213.5 m, which included 1.5 m of freeboard from the Probable Maximum Flood (PMF) elevation of 1212.0 m. This increased storage volume was achieved in part by moving the dam further downstream (southeast) to within approximately 100 m of the top of Elbow River north bank.

Reference: Dam Alignment and Toe Location

A comparison of the IDC (June 2014) and Stantec conceptual design (May 2015) storage dam alignment is shown in Attachment 1.

CONSIDERATIONS

The following sections include considerations relative to general site conditions, river bank erosion rates, and geotechnical conditions.

GENERAL SITE CONSIDERATIONS

Stantec performed site reconnaissance along the toe of the Elbow River banks near the dam toe area on May 3, 2016. Two gullies were observed near the location where the dam toe is closest to the top of the Elbow River bank. The two gullies are shown in Attachment 1 in plan view. Photographs of the gullies are shown below in Figure 1; the photographs give good perspective on the size and scale of the gullies. The gullies were not reviewed in detail due to land access constraints.



Figure 1. West Gully (left) and East Gully (right).

RIVER BANK EROSION RATE

Stantec reviewed peer-reviewed literature, agency guidance documents, and engineering design manuals that included methods of determining bank erosion and bank retreat rates appropriate for the Elbow River at the proposed dam toe. A number of potentially applicable

Reference: Dam Alignment and Toe Location

methods were found based on historic aerial photography, empirical relationships, and bank physics and hydraulics. Estimation of bank erosion and migration is a complex proposition resulting from a number of concurrent and potentially synergistic fluvial and geotechnical processes; therefore, the rates presented below are intended to provide an envelope of potential erosion rates that may be possible near the proposed dam embankment location based on available data, both field collected and remotely sensed.

Estimates based on historical imagery provide more accurate estimates of erosion and bank retreat, as they can consider historic channel activity over large spatial and temporal scales, and are based on directly measured data. Three methods of analysis for historical imagery were chosen for this project: direct aerial photo comparison, maximum migration method, and eroded area polygon method. Direct photo comparison is the most straightforward method, where bank lines are digitized from historic photos and the distance between successive bank lines are measured along a transect. The rate generated is an instantaneous value rather than the reach average bank retreat rate. Maximum migration rate involves fitting an arc to the outside bank of a bend and then measuring the maximum difference between successive photos. This method generally provides a conservative estimate of the retreat rate, and can be applied to situations involving bend expansion, bend translation, or bend rotation rather than just bank retreat. Eroded area polygon generates a bend average bank retreat rate by determining the area between successive bank lines, then dividing by the perimeter of the resulting erosion polygon to calculate a bend average distance of erosion perpendicular to the channel. Results from these three methods give similar average annual rates of bank retreat for the period of record, 1964 through 2013. See Table 1 for a summary of erosion rate results.

Of the empirically- and physically-based models considered, the most appropriate for use on this project are the bend curvature ratio method presented by Hickin and Nanson (1986) and the excess shear method. Bend curvature ratio uses measured data from the reach and applies it to a relationship of channel morphology to erosion rate based on data collected from a number of rivers in Alberta and British Columbia. As such, it allows an empirical estimation of erosion rate in the context of a variety of geomorphic conditions in the Elbow River's geophysical and climatic setting.

Excess shear is a method with a less empirical basis; it calculates the erosion rate of the bank based on the difference between shear stress applied to the bank and soil critical shear stress, modified by the erodibility of the bank material. The results for a single bankfull (1.5-year) event with soil parameters estimated from soil survey data map unit of the terrace is 0.5 metres; however, this could be further refined with laboratory soil data from boring D27 (not drilled yet as of July 1, 2016) or manipulated based on a storm event's flow magnitude or duration, or by varying applied shear stress on the bank. Scalability, input variability, and reliance on physical parameters add to this method's utility and applicability. Estimates of larger events are difficult to obtain, but a reasonable estimate of bank retreat due to a 25-year flood event is approximately 5 metres.

We recommend considering an average annual erosion rate ranging from 0.5 m/yr to 1.0 m/yr for areas near the proposed SR1 dam embankment toe.

Reference: Dam Alignment and Toe Location

Table 1: Estimated Bank Erosion Rates from Recommended Methods

<u>Method</u>	<u>Estimated Erosion Rate</u>	<u>Theoretical Basis</u>
Direct Photo Comparison	0.4 m/yr	Aerial photos/Historic channel behavior
Maximum Migration	0.5 m/yr	Aerial photos/Historic channel behavior
Eroded Area Polygon	0.3 m/yr	Aerial photos/Historic channel behavior
Bend Curvature Ratio	0.7 m/yr	Empirical relations among rivers in BC and AB
Excess Shear	0.5 m/bkf event	Hydraulics and bank material properties

GEOTECHNICAL

Slope instability is a common geohazard along the rivers in both the Calgary region and Southern Alberta, and typically manifest as complex rotational and/or translational failures in glacial units caused by river erosion or through man-made development, which increases the groundwater elevation, impedes drainage or surcharges the slopes. Rockfalls can occur within the Paskapoo Formation (which underlies the area of interest), typically due to undercutting of non-durable layers or wedge failures.

Site walkovers and aerial photographs have indicated that the natural slopes of the Elbow River downstream of the proposed dam toe undergo frequent slope instability, with complex rotation failures being the dominant failure mechanism (Figure 2 shows the river bank near the dam toe). The slopes are a dynamic system, in which equilibrium is recurrently disturbed by channel migration. Observations indicate the following cycle of slope regression:

- Slope at equilibrium;
- Channel migration towards the slope;
- Initiation of erosion of the toe (disturbing agent);
- Over-steepening of the slope with subsequent rotational failure. This forms a localized circular back-scarp in plan view divided by spines of steeper material;
- The steeper spines lose support and material gradually fail as blocks (wedge failure); and,
- Surface water, progressive slumping and establishment of vegetation further modify the slope until it reaches equilibrium

The following preliminary geotechnical assessment has been undertaken to determine:

Reference: Dam Alignment and Toe Location

- If the current dam alignment meets the required factor of safety (FOS) based on the existing topography with no additional engineered solutions; and if so,
- How much lateral erosion is required to compromise its stability.



Figure 2. Elbow River Bank near the Dam Toe.

Stantec performed drilling and laboratory testing at 15 boreholes as of May 18, 2016; the boreholes completed are shown below in Figure 3.

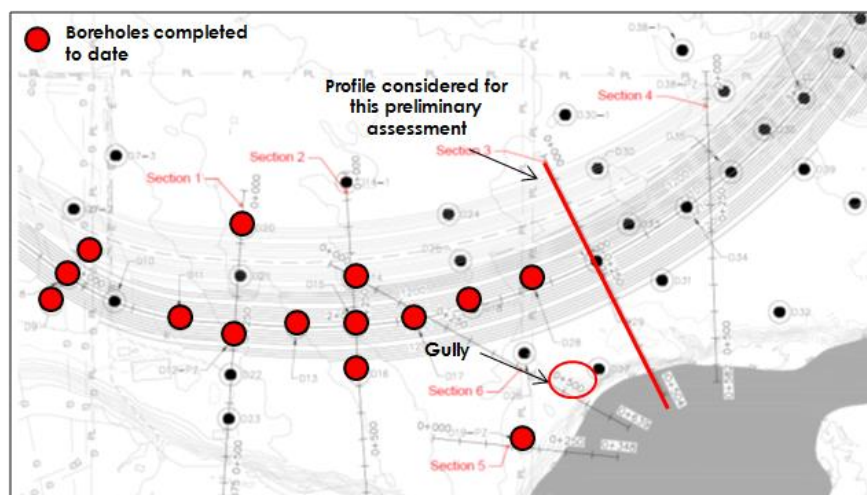

Note: Storage dam alignment shown is from current concept (April 2015)

Reference: Dam Alignment and Toe Location

Figure 3. Boreholes Completed and Location of the Analyzed Slope/W Section

The stability analysis was undertaken using Slope/W@ v12 to calculate the critical failure surface. Optimization was undertaken for the critical failure surfaces. However, unrealistic slip surfaces, which can be generated by the optimization method, were ignored, where applicable.

The Morgenstern-Price (1965) method was used for all the stability analyses.

The groundwater level was assumed to be at original ground (OG) elevation upstream and beneath the dam, with a straight line interpolation from the downstream toe of the dam to the river elevation. In the stability analysis, this assumption was applied to all foundation materials. Materials placed above OG were assumed to add weight. The reservoir under steady state conditions was modeled as a second phreatic surface and was assumed to be controlled by the filter drain located on downstream face of the core.

Preliminary material strength and pore pressure parameters were used in the stability analysis. The values were developed from the limited available site data, typical values for the soil/rock materials encountered, and from experience. These values will change as the full drilling and laboratory results become available. The material strength and pore pressure parameters used in the stability analysis are summarized in Table 2.

Results

The results of the existing conditions stability analysis are summarized in Table 3 and the generalized location of the failure surfaces are shown in Figure 4.

Table 2. Material Parameters

Material	Unit weight (kN/m ³)	Φ' (°)	c (kN/m ²)	Pore Pressure Parameters ⁽¹⁾
Zone 1 Core	21	32	0	r _u = 0.4
Zone 2 Random Fill	21	30	0	r _u = 0.3
Filter	21	33	0	Piezometric
Fluvial	20	33	0	Piezometric
Glacio-lacustrine	20	20 ⁽²⁾	S _u / σ' _v = 0.36	\bar{B} = 0.4
Glacial Till	20	27 ⁽²⁾	0	\bar{B} = 0.3
Paskapoo Formation (Mudstone unit)	21	17.5 ⁽⁴⁾	0	\bar{B} = 0.5
Paskapoo Formation (Sandstone unit)	21	45	0	Piezometric

1. Pore pressure parameters based on experience working with glacial units and Cretaceous argillaceous materials in Northern Alberta. Not site specific.
2. Drained parameters based on CUD tests and empirical relationships.
3. If applicable, the undrained strength is modeled using the 'Stress history and normalized soil engineering' (SHANSEP) approach developed by Ladd and Foott (1974). Undrained strength ratio conservatively based on Mayne et al (2001).
4. Mudstone layer assumed to have mobilized residual strength.

Reference: Dam Alignment and Toe Location

Table 3. Results of the Slope/W Analysis

Ref	Operational Conditions	Minimum FOS		
		Undrained GL	Drained GL	Failure to River
1	End of construction; no reservoir. Pore pressures modeled with \bar{B} and r_u	1.1	1.0	1.5
2	Operational, steady state reservoir at El. 1212 m. Pore pressures modeled as piezometric surface and no \bar{B} and r_u	1.5	1.4	1.7

Note: GL stands for glacio-lacustrine.

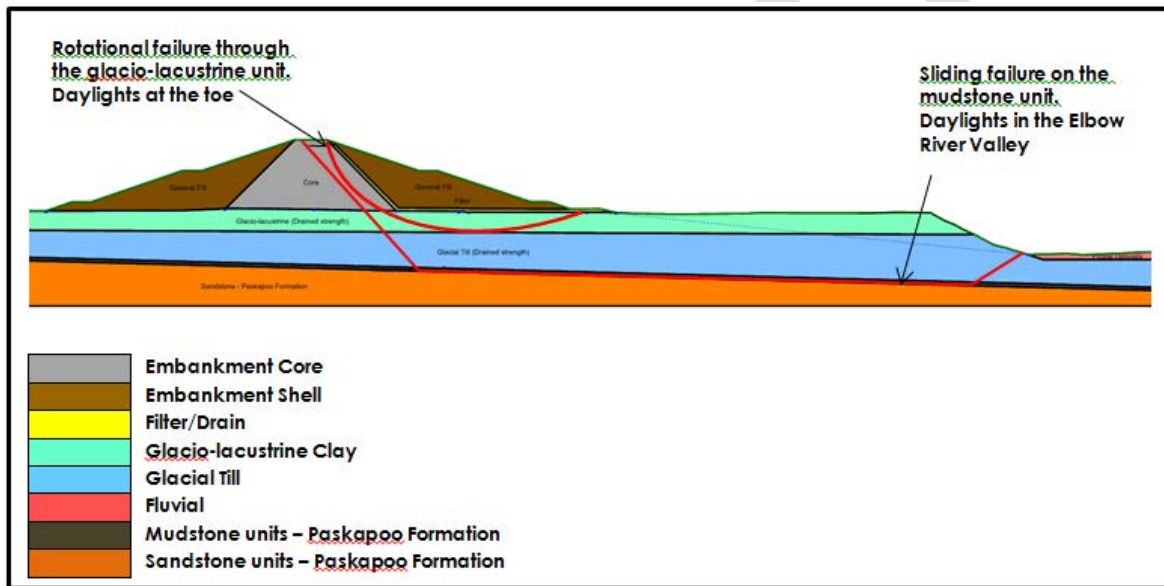

Figure 4. Generalized Failure Surfaces

Once the current design alignment conditions were analyzed for drained and undrained strength conditions, lateral erosion of the river bank was modeled using an iterative process to move the river bank closer to the toe of the dam at varying distances. This condition was analyzed assuming the reservoir is full at elevation 1212 m with the phreatic surface following the filter drain and then straight lined from the toe of the dam to the river surface. Both the entry / exit method and the fully specified failure surfaces were evaluated to determine the lowest factor of safety. It was assumed river erosion would occur long after the construction of the dam, so construction loading with excess pore pressure analysis was not considered. The results of this stability analysis are summarized in Table 4.

Reference: Dam Alignment and Toe Location

Table 4. Results of the Slope/W Analysis with Failure to the River

Ref	Operational Conditions ⁽¹⁾	Distance from Toe of Dam to River Crest, "L" (m)	Factor of Safety ⁽³⁾
1	Steady state reservoir at El. 1212m	114 ⁽²⁾	1.7
2	Steady state reservoir at El. 1212m	83	1.5
3	Steady state reservoir at El. 1212m	70	1.5
4	Steady state reservoir at El. 1212m	55	1.4
5	Steady state reservoir at El. 1212m	26	1.2
6	Steady state reservoir at El. 1212m	0	1.2

1. Pore pressures modeled as piezometric surface along the filter drain with straight line from toe of dam to river.
2. Currently proposed distance from dam toe to top of river bank.
3. Factor of safety for failures through the river bank through the mudstone layer.

The generalized location of the failure surface is shown in Figure 4. The failure surface goes through the weaker mudstone layer. As the river bank was moved closer to the toe of the dam in order to model future lateral erosion of the river bank, the failure surface continued to go through the mudstone layer.

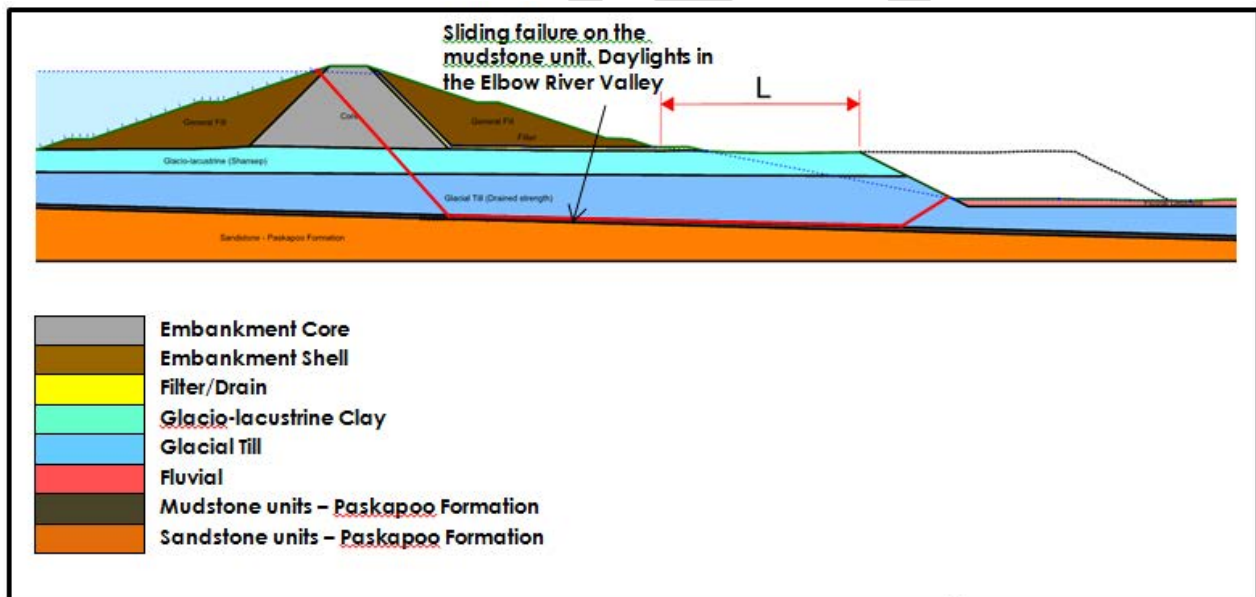

Figure 5. Iterative Lateral Erosion Analysis

The analysis for the current alignment conditions with the dam constructed ignoring potential lateral river bank erosion showed adequate factors of safety (1.5) for long term conditions with the reservoir full using a c/p ratio to characterize the strength of the glacio-lacustrine clay. The critical failure

Reference: Dam Alignment and Toe Location

surface for this scenario was a rotational failure through the toe of dam in the foundation glacio-lacustrine clay.

The potential impact of lateral river bank erosion was evaluated. The lateral river bank erosion does not impact the critical failure surface until the top of the river bank is 70 metres from the toe of the dam. This equates to approximately 44 metres of lateral erosion. At this distance, the factor of safety is equal to 1.5 and the critical failure surface is no longer the rotational failure through the toe of the dam but a sliding failure along the mudstone unit in the Paskapoo formation toward the river.

ALTERNATIVES

Stantec has developed three preliminary alternatives for the dam toe location. These alternatives are intended to mitigate geotechnical stability and river instability risks and are described below.

ALTERNATIVE 1 - DAM TOE IN CURRENT LOCATION, MONITOR

A conservative average erosion rate of 1.0 m/year results in an unacceptable factor of safety in approximately 50 years. A single large scale event, like the 2013 flood, is not likely to result in more than 10 metres of erosion based on our review of recent aerial photography and river alignments. The slow rate and timescale for this erosional process to occur are such that they would allow the implementation of slope stabilization, river training structures discussed below as Alternative 2, or other corrective actions when routine dam inspections indicate the erosion is threatening slope stability.

ALTERNATIVE 2 - DAM TOE IN CURRENT LOCATION, BANK TOE STABILIZATION

Along this reach, the Elbow River has a wide, partially braided active channel that is largely unconfined and is free to meander and switch within the valley bottom and its shallow floodplains. One area of partial confinement is where the channel runs against the toe of the terrace that is the subject of this memo. The wide active channel and valley shape result in flood depths through this reach that are relatively shallow; however high velocities, turbulence, bedload and debris can rapidly affect water levels, and must also be considered in any river training, or bank toe stabilization solution. The unconfined nature of the river also lends itself well to river training or diversion.

For this conceptual design it is recommended that river training or toe stabilization be designed to a 100-year design flood standard without the operation of SR1 (760 m³/s). A freeboard elevation of 1 m is recommended for works that are not stable when overtopped. Subject to detailed analysis, it is estimated that total net scour potential at bluff bodies (like groyne noses) in this section of the Elbow River at 760 m³/s will not exceed 4.5 m.

Should river training or toe stabilization become the preferred option then it is recommended that more detailed 2D hydraulic modelling be used to identify local velocities, their vector angles, and total net scour potential. The results of that modeling would then be used for final design.

Using the above noted design parameters, two conceptual options have been developed that would mitigate erosion at the toe of the terrace from the Elbow River (and activation of its sub-channels). Both options focus on the critical sections where the distance from the toe of the dam to

Reference: Dam Alignment and Toe Location

the toe of the terrace is smallest. This assumes that monitoring would be sufficient to address erosion in the less-critical locations along the terrace.

Alternative 2A – Groynes as River Training Structures

Groynes are long projections of earth or rock fill that disrupt flow patterns and can be used to effectively 'push' the river away from areas of high erosion potential. There are several types of groyne configurations available; however, a key consideration when determining the type and arrangement of groynes is the availability of materials and the length of reach which is to be altered. Attachment 2 identifies an arrangement that uses 5 non-overtopping, repelling groynes to achieve the desired protection.

The proposed groynes are comprised of vegetated earth fill with a class II riprap cap on their ends and a self-launching apron for scour protection. The use of non-armoured earth fill is recommended because of the length of the spurs and the amount of material required to cover the length of the reach to be protected. The use of earth fill means the spurs cannot be overtopped during the design event and therefore a 1 metre freeboard has been applied to their height. Non-overtopping groynes produce a hydraulic shadow of ineffective flow area that extends at a 1:1 angle upstream and a 4:1 angle downstream as shown in Attachment 2 and is the basis for this conceptual arrangement. Shorter groynes reduce the length of this zone of influence; and thus, would require additional groynes to achieve the same length of protection.

The opinion of probable construction cost of Alternative 2A is approximately \$ 3.4 million.

Water Act approval would be required for the implementation of the groynes. There are environmental components to the *Water Act* but a key aspect of the review would be the effect of the groynes on flood levels and diversion of the river's main channel. Because of the shallow banks and unconfined nature of the Elbow River at this location, the impacts to flood levels are expected to be minimal; however, hydraulic modeling would be required to confirm this.

Groynes G1, G2 and G3 are located entirely on sub-channels and floodplain areas and not within the current active main channel. Groynes G4 and G5 do affect the alignment of the main channel and *Fisheries Act* authorization would be required for the realignment. The location of these groynes in the main channel may also challenge environmental aspects of the *Water Act* approval; however, appurtenances like small vanes off the armored nose, boulder runs and joint planting of willows in the riprap voids can be added to the design to help offset impacts to the aquatic environment and facilitate regulatory approval.

The groynes are arranged such that they do not affect the common right to navigation; however, 2D hydraulic modelling is recommended to confirm this. A Disposition License of Occupation would also be required under the *Public Lands Act* to accommodate the footprint of the works within the bed and shore of the river (crown land).

Alternative 2B – Constructed Terrace with Riprap Revetment

A common stabilization method for tall slopes alongside rivers is to construct a terrace long its toe. The fill placed in the constructed terrace can serve as ballast against global instabilities and can

Reference: Dam Alignment and Toe Location

serve as an additional buffer to erosion, particularly if plants and rock armour are used to resist loss of the fill material. Attachment 3 provides a conceptual arrangement for a constructed terrace that would prevent the erosion of the larger slope's toe.

This concept uses an assumed 10 m wide vegetated 'bench'; however, the actual dimensions of the terrace bench are subject to geotechnical recommendations on ballast needs for global stability. The terrace can be constructed of native fill and the bench can be planted with trees as well as shrubs and native seed. Erosion protection is provided by a class II riprap revetment with a self-launching apron along the riverside face of the terrace. Voids in the revetment's riprap can be filled with loam and joint planted with willow cuttings or plugs (as shown). Though not required along its entire extent it is recommended to include the planting in the parts of the revetment that encroach on the existing main channel to help offset impact and facilitate regulatory approvals.

The opinion of probable construction cost of Alternative 2B is approximately \$ 7.2 million.

The constructed terrace and revetment has less hydraulic impact than groynes and is less aggressive a diversion of the river channel; however there are developing concerns among the regulators about large tracts of riprap and include: loss of dynamism in the aquatic environment, loss of shade and feeding areas; and, impacts to wildlife passage. Similar to Alternative 2A, the constructed terrace and revetment would require *Fisheries Act* authorization, *Water Act* approval and a disposition license of occupation for any portions that encroach on the bed and shore of the Elbow River, or any other portions of crown land. The revetment is not expected to affect the common right to navigation.

ALTERNATIVE 3 - RELOCATE DAM UPSTREAM

The third alternative for addressing bank erosion risks is to relocate the dam approximately 100m upstream from the current concept, locating it approximately 200 m from the top of bank of the Elbow River at its closest location. Relocation of the storage dam further upstream would have a relatively small impact on reservoir storage. SR1 storage needs of the 2013 storm event produces a level flood pool elevation of 1210.3 m for the current concept. Moving the dam upstream would raise the pool elevation to 1210.6 m given the same storage needs.

The storage dam emergency spillway in the conceptual design was a labyrinth spillway sized to discharge 700 cms at a head of 1.5 m. The raising of the storage pool when the dam is relocated further upstream will increase the emergency spillway invert from 1210.5 m to 1210.6 m. As a result, the design head for the emergency spillway is reduced from 1.5 m to 1.4 m. This lower head requires an increase in the crest length of the labyrinth spillway. Individual cycles of the labyrinth spillway were widened and lengthened downstream by 1 m in each direction. With six labyrinth cycles, the resulting structure will need to be widened by 6 m for a total width of 68 m and will increase the cost of this structure by approximately 10% or \$700,000.

Attachment 4 shows this alternative dam alignment. Conceptual versus alternative storage dam quantity impacts are shown in Table 5.

Reference: Dam Alignment and Toe Location

Table 5: Dam Alternative Quantities

Dam Alternative	Fill Quantity (m ³)	Footprint Area (m ²)	Centerline Length (m)
Current Concept	3,693,350	382,400	3,500
100m Upstream	3,637,800	375,850	3,375

Note: Quantities do not include emergency spillway embankment

DISCUSSION

Alternatives 1 and 3 would contain project work within the existing project boundary. No new properties would need to be acquired as a part of these proposed alternatives. Alternative 2 involves proposed work exceeding the current project boundary at a maximum of approximately 75 metres, in the case of Alternative 2.A, and approximately 10 metres in the case of Alternative 2.B.

For Alternatives 1 and 2, the dam height and components will be the same as in the conceptual design. If the dam is moved upstream as described in Alternative 3, the dam height can remain the same if the design head of the spillway is decreased to reflect an increase in the reservoir pool elevation for the 2013 design storm event.

See Table 6 for an estimated probable capital cost comparison of the various alternatives considered.

Table 6: Alternatives Cost Comparison

Alternative	Added Costs	Reduced Costs	Net Change
Alternative 1 – Monitor	\$0	\$0	\$0
Alternative 2A – River Groyne Structures	\$3.4 million	\$0	\$3.4 million
Alternative 2A – Terrace and Revetment	\$7.2 million	\$0	\$7.2 million
Alternative 3 – Relocate Dam US	\$700,000 ⁽¹⁾	\$85,000 ⁽²⁾	\$615,000

1. Expansion of Storage Dam Emergency Spillway.
2. Reduced random fill quantity needed for Storage Dam.

Reference: Dam Alignment and Toe Location

RECOMMENDATION

Stantec recommends moving the Dam up-valley 100 metres from the preliminary design concept location presented in April 2015. The impacts of this change are negligible for cost (fill quantity and emergency spillway) and footprint area.

REFERENCES

AMEC (2014). *Flood Mitigation Measures for the Bow River, Elbow River and Oldman River Basins: Volume 4 – Final*. Southern Alberta Flood Recovery Task Force. June, 2014.

Hanson, G.C. and E.J. Hickin (1986). *A Statistical Analysis of Bank Erosion and Channel Migration in Western Canada*. *Geological Society of America Bulletin* 97: 497-504.

Hickin, E.J. and G.C. Nanson (1975). *The Character of Channel Migration on the Beatton River, Northeast British Columbia, Canada*. *Geological Society of America Bulletin* 86: 487-494.

Ladd, C.C. and R. Foott (1974). *New Design Procedure for Stability of Soft Clays*. *Journal of Geotechnical Engineering* 100 (GT7): 763–786.

Mayne, P.W., et. al. (2001). *Manual on Subsurface Investigations*. National Highway Institute Publication No. FHWA NHI-01-031 Federal Highway Administration. July, 2001.

Morgenstern, N. R. and V.E. Price (1965). *The Analysis of the Stability of General Slip Surfaces*. *Geotechnique* 15(1): 79–93.

Stantec (2015). *Springbank Off-Stream Reservoir (SR1) – Conceptual Design Update*. March 31, 2015.

Stantec Consulting Services Inc.

Hugo Aparicio, PE
Senior Principal
Phone: 859-422-3000
Hugo.Aparicio@Stantec.com

Scott Peyton, PE
Senior Principal
Phone: 513-842-8200
Scott.Peyton@Stantec.com

Attachment: Attachments 1-4

c. John Montgomery, John Menninger, Norm Fallu, Eric Monteith

PlotDate: 2016.07.06 2:17 PM Login: White, Jarred
 TENDER No. ?
 AUTOCAD FILE No. U:\110773396\component_work\dams_diversion\civil\drawing\30_percent\exhibits\Dam_Toe_Memo\Attach_1_Concept_Compare.dwg

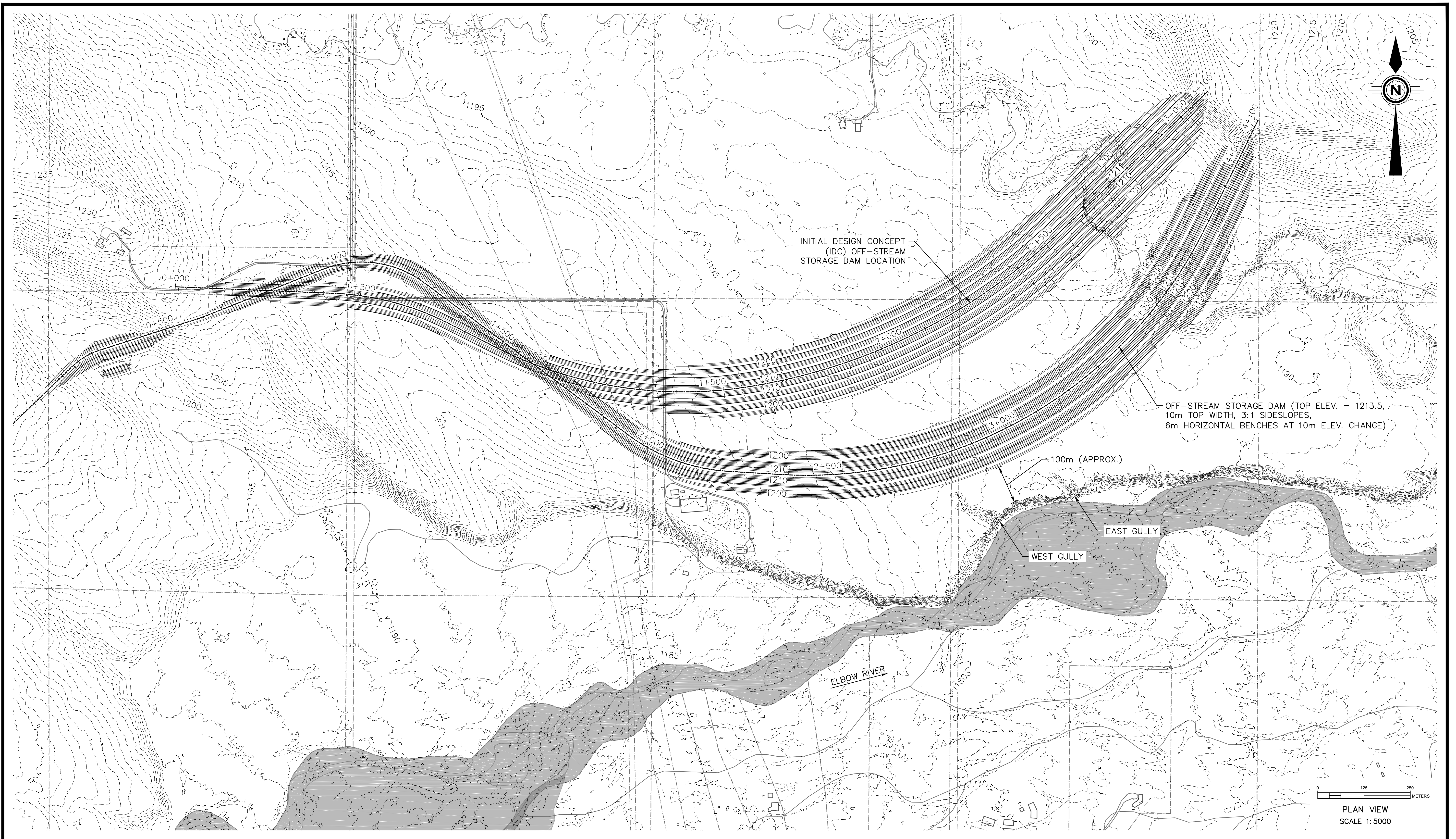

THIS DRAWING MAY HAVE BEEN REDUCED.
 ALL SCALE NOTATIONS INDICATED (i.e. 1:1000 etc)
 ARE BASED ON 22" X 34" FORMAT DRAWINGS

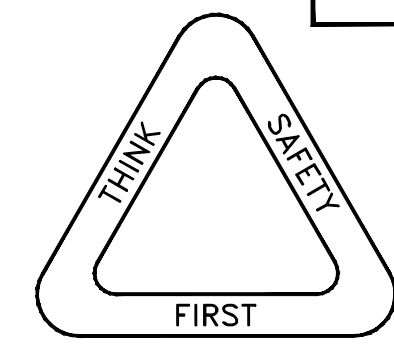

Stantec
 Project No.: 110773396
 200 - 325 25th Street SE
 Calgary AB Canada T2A 7H8
 Tel. 403.716.8000
 www.stantec.com

REV	DATE	REVISIONS	BY

PRELIMINARY - NOT FOR CONSTRUCTION

DATE: 2016-07-06

DESIGNER	CHECKER
DATE	DATE

ALBERTA ENVIRONMENT AND PARKS CAPITAL PROJECTS NUMBER

Alberta
 Transportation

SITE: SR1 - ROCKY VIEW, ALBERTA

SPRINGBANK OFF-STREAM STORAGE PROJECT

DAM ALIGNMENT AND TOE LOCATION
 RELATIVE TO THE ELBOW RIVER
 ATTACHMENT 1
 STORAGE DAM LOCATION -
 CONCEPT COMPARISON

SHEET: 1 OF 7	CONSULTANT DRAWING	TRANSPORTATION DRAWING
---------------	--------------------	------------------------

DEPARTMENT BAR CODE

PlotDate: 2016.07.06 10:37 AM Login: White, Jarred
 AUTOCAD FILE No. U:\110773396\component_work\dams_diversion\civil\drawing\30_percent\exhibits\Dam_Toe_Memo\ELBOW_RIVER_TRAINING_STRUCTURES_2A.dwg TENDER No. ?

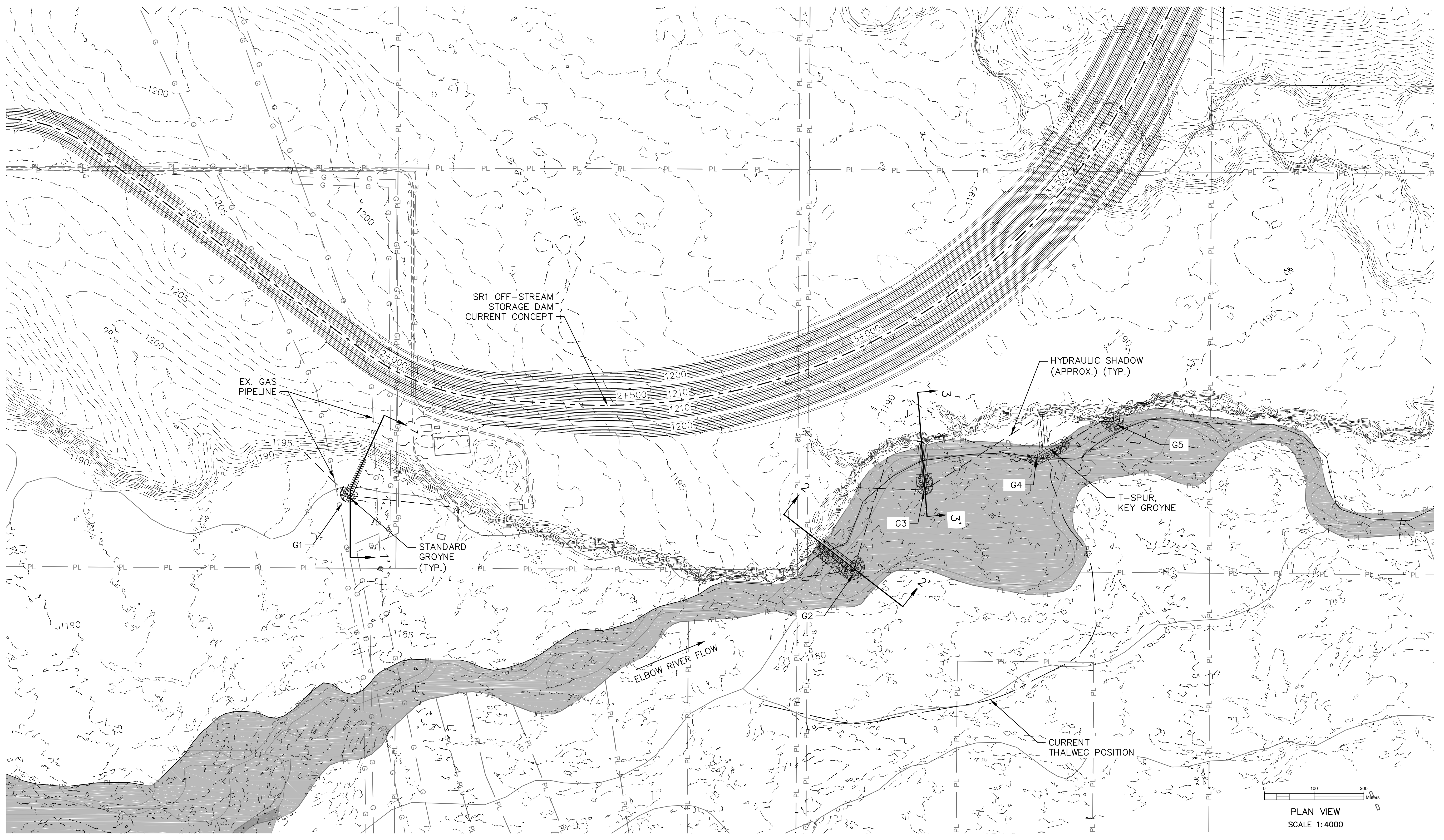

THIS DRAWING MAY HAVE BEEN REDUCED.
 ALL SCALE NOTATIONS INDICATED (i.e. 1:1000 etc)
 ARE BASED ON 22" X 34" FORMAT DRAWINGS

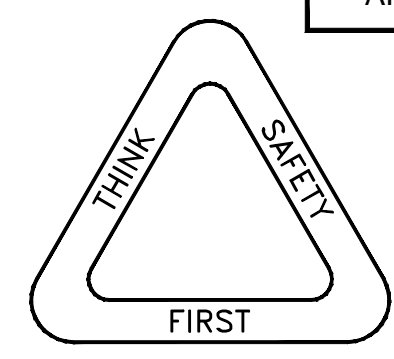

Stantec
 Project No.: 110773396
 200 - 325 25th Street SE
 Calgary AB Canada T2A 7H8
 Tel. 403.716.8000
 www.stantec.com

REV	DATE	REVISIONS	BY

PRELIMINARY - NOT FOR CONSTRUCTION	DESIGNER	CHECKER
	DATE	DATE
2016-07-06	ALBERTA ENVIRONMENT AND PARKS CAPITAL PROJECTS NUMBER	

Alberta
 Transportation

SITE
 SR1 - ROCKY VIEW, ALBERTA

SPRINGBANK OFF-STREAM STORAGE PROJECT		
DAM ALIGNMENT AND TOE LOCATION RELATIVE TO THE ELBOW RIVER ATTACHMENT 2-1 RIVER TRAINING STRUCTURES CONCEPT OPTION 2A - PLAN		
SHEET	CONSULTANT DRAWING	TRANSPORTATION DRAWING
2 OF 7		

PLAN VIEW
 SCALE 1:4000

PlotDate: 2016.07.06 10:42 AM Login: White, Jarred
 TENDER No. ?
 AUTOCAD FILE No. U:\110773396\component_work\dams_diversion\civil\drawing\30_percent\exhibits\Dam_Toe_Memo\RIVER_TRAINING_STRUCTURES_2A.dwg

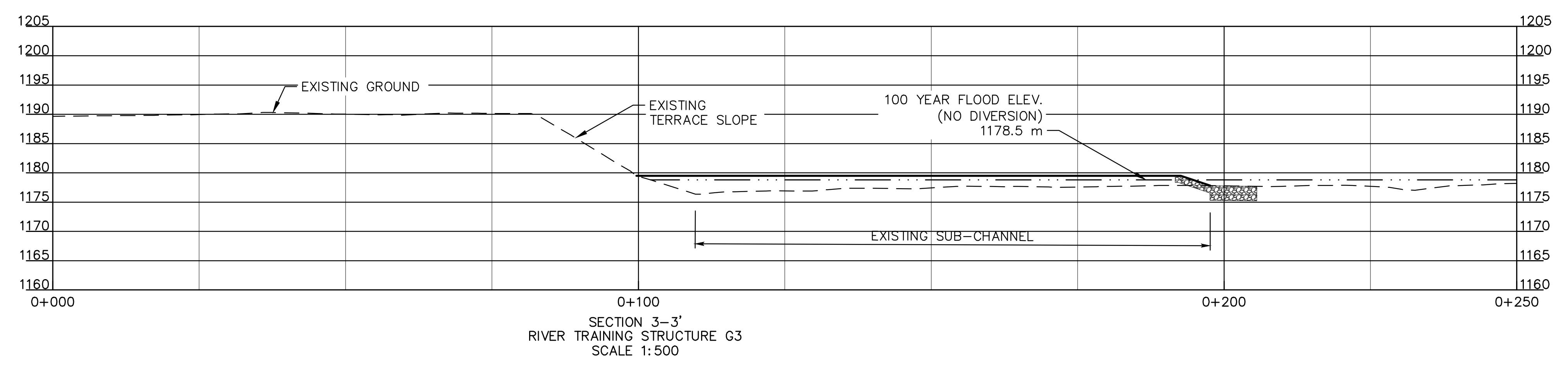
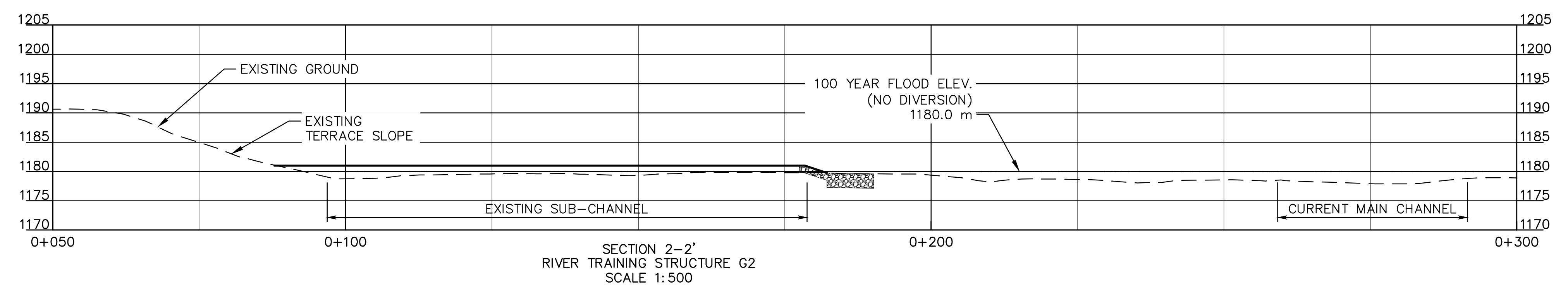
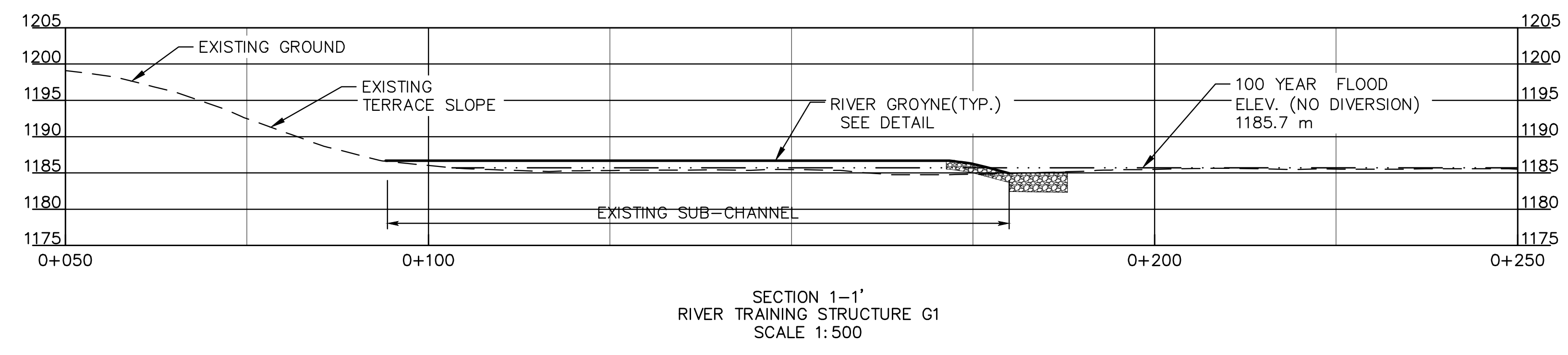

THIS DRAWING MAY HAVE BEEN REDUCED.
 ALL SCALE NOTATIONS INDICATED (i.e. 1:1000 etc)
 ARE BASED ON 22" X 34" FORMAT DRAWINGS

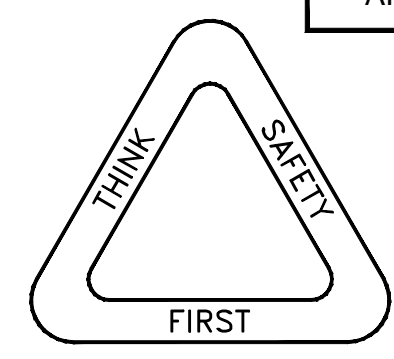

Stantec
 Project No.: 110773396
 200 - 325 25th Street SE
 Calgary AB Canada T2A 7H8
 Tel. 403.716.8000
 www.stantec.com

REV	DATE	REVISIONS	BY
6			
5			
4			
3			
2			
1			

PRELIMINARY - NOT FOR CONSTRUCTION

DESIGNER	CHECKER
DATE	DATE
2016-07-06	

ALBERTA ENVIRONMENT AND PARKS CAPITAL PROJECTS NUMBER

Alberta
 Transportation

SITE
 SR1 - ROCKY VIEW, ALBERTA

SPRINGBANK OFF-STREAM STORAGE PROJECT
 DAM ALIGNMENT AND TOE LOCATION
 RELATIVE TO THE ELBOW RIVER
 ATTACHMENT 2-2
 RIVER TRAINING STRUCTURES
 CONCEPT OPTION 2A - SECTIONS

SHEET	CONSULTANT DRAWING	TRANSPORTATION DRAWING
3 OF 7		

PlotDate: 2016.07.06 10:42 AM Login: White, Jarred
 TENDER No. ?
 AUTOCAD FILE No. U:\110773396\component_work\dams_diversion\civil\drawing\30_percent\exhibits\Dam_Toe_Memo\GROYNE_DETAIL.dwg

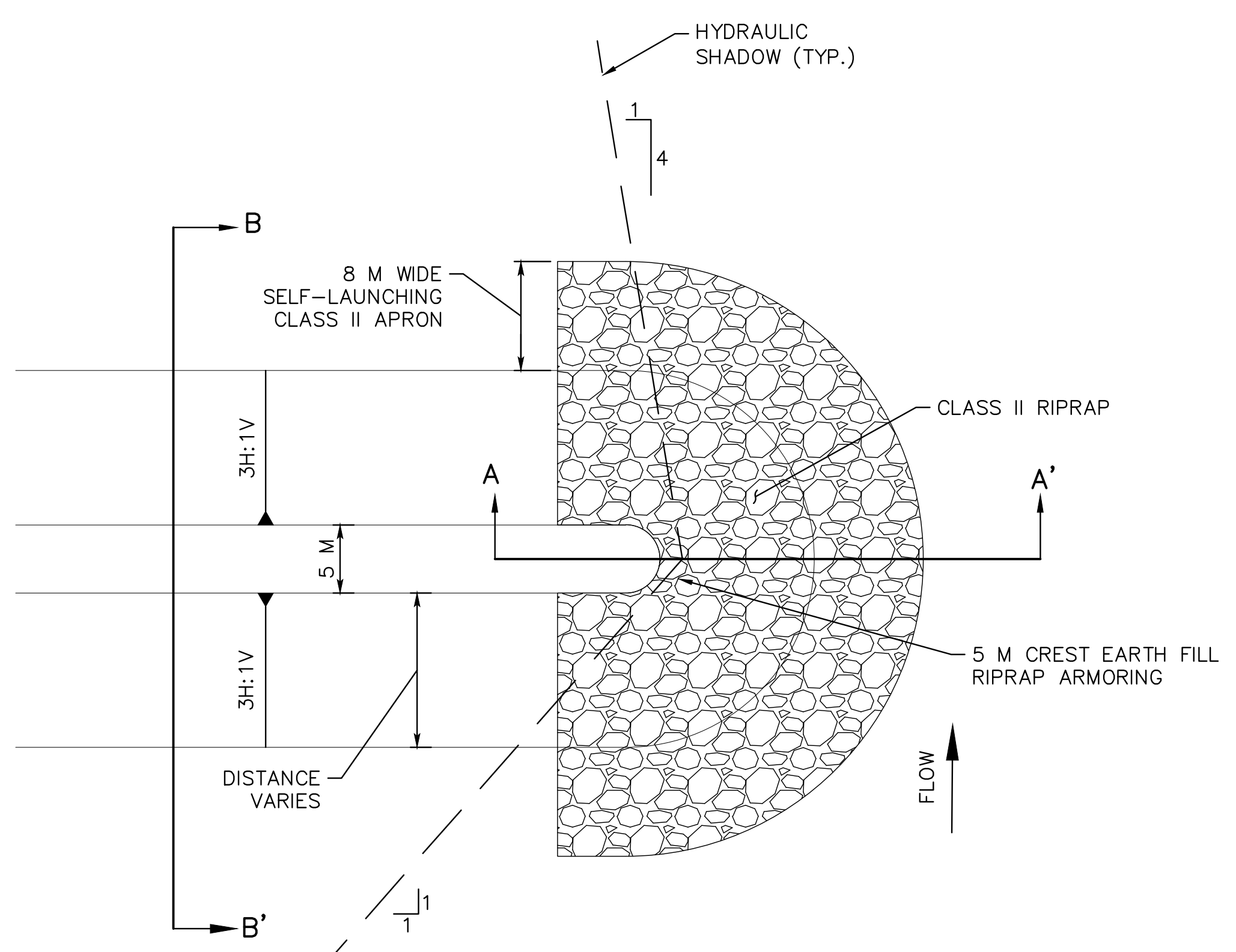

GROYNE PLAN DETAIL
SCALE 1:1000

CLASS II RIPRAP GRADATION

% PASSING	STONE SIZE	
	DIA. (MM)	MASS (KG)
100	800	700
30-80	600	300
20-50	500	200
5-20	300	40

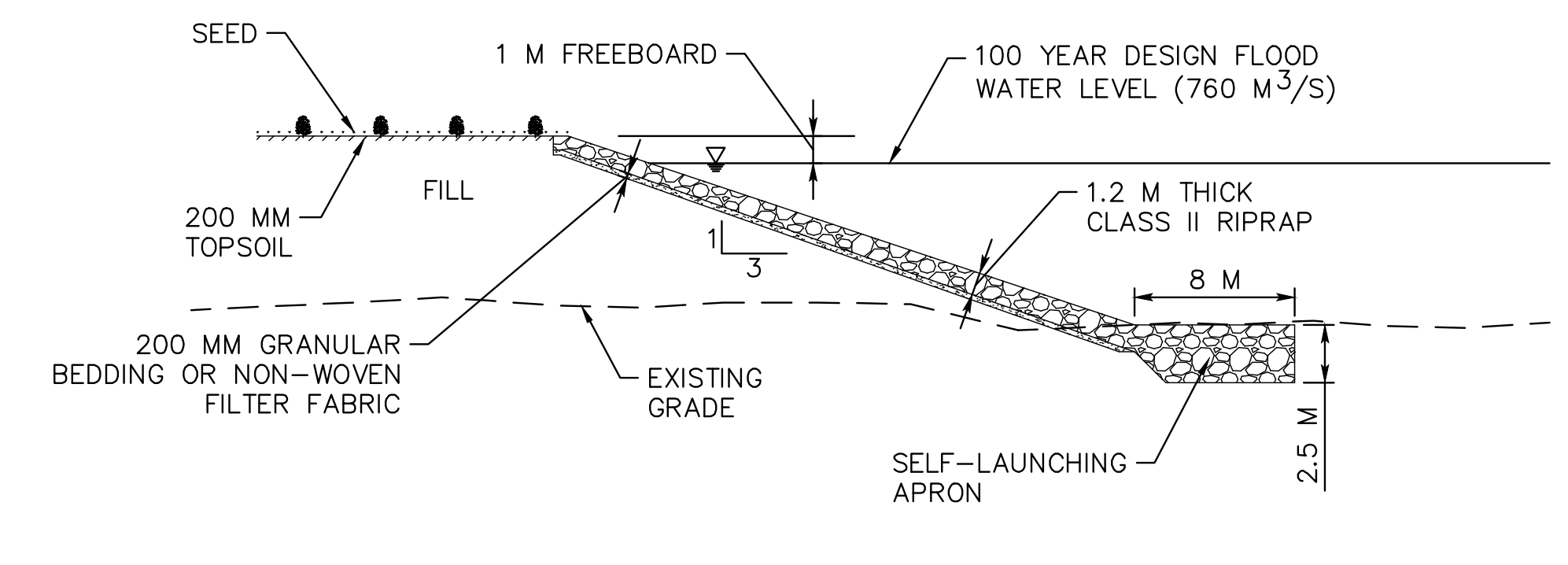

SECTION A-A'
GROYNE ARMOR DETAIL
NOT TO SCALE

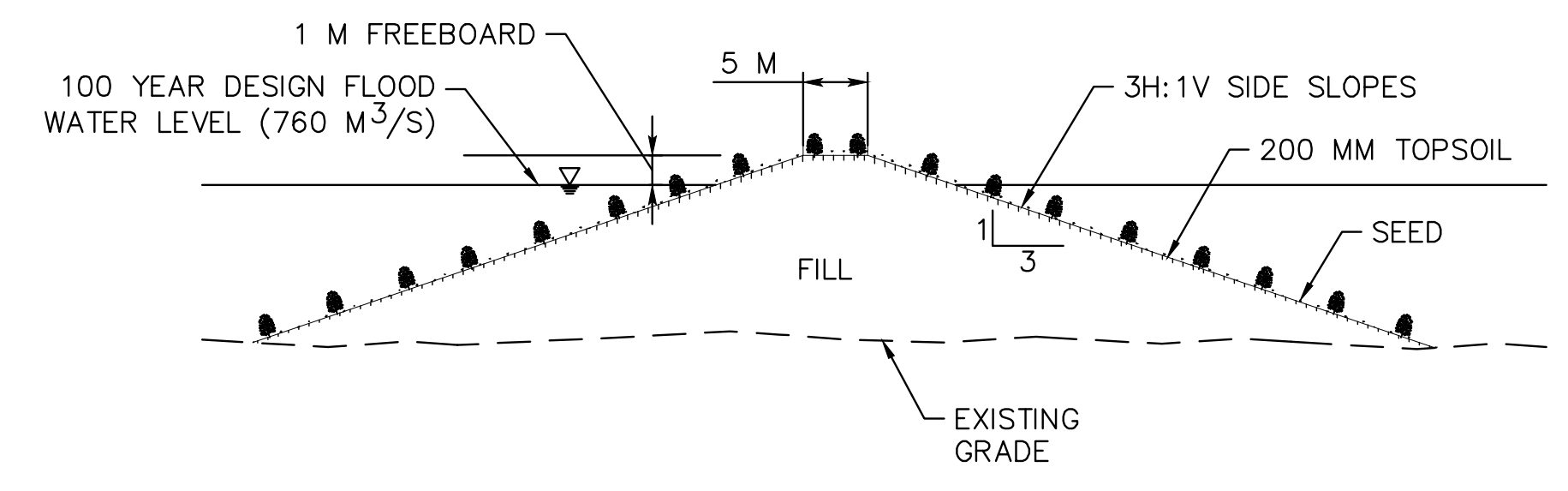

SECTION B-B'
GROYNE SHANK DETAIL
NOT TO SCALE

PLAN AND SECTION DETAIL
OPTION 2A
GROYNE ARMORING AND
LANDSCAPING DETAILS
NOT TO SCALE

THIS DRAWING MAY HAVE BEEN REDUCED.
ALL SCALE NOTATIONS INDICATED (i.e. 1:1000 etc)
ARE BASED ON 22" X 34" FORMAT DRAWINGS

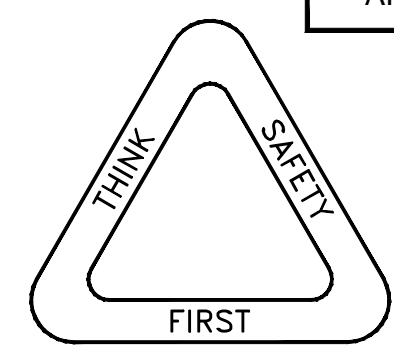

Stantec
Project No.: 110773396
200 - 325 25th Street SE
Calgary AB Canada T2A 7H8
Tel. 403.716.8000
www.stantec.com

REV	DATE	REVISIONS	BY

PRELIMINARY - NOT FOR CONSTRUCTION

DESIGNER	CHECKER

DATE	ALBERTA ENVIRONMENT AND PARKS CAPITAL PROJECTS NUMBER
2016-07-06	

Alberta
Transportation

SR1 - ROCKY VIEW, ALBERTA

SHEET	CONSULTANT DRAWING	TRANSPORTATION DRAWING
4 OF 7		

SPRINGBANK OFF-STREAM STORAGE PROJECT
DAM ALIGNMENT AND TOE LOCATION
RELATIVE TO THE ELBOW RIVER
ATTACHMENT 2-3
RIVER TRAINING STRUCTURES
CONCEPT OPTION 2A - DETAILS

PlotDate: 2016.07.06 11:02 AM Login: White, Jarred
 AUTOCAD FILE No. U:\110773396\component_work\dams_diversion\civil\drawing\30_percent\exhibits\Dam_Toe_Memo\ELBOW_RIVER_TRAINING_STRUCTURES_2B.dwg TENDER No. ?

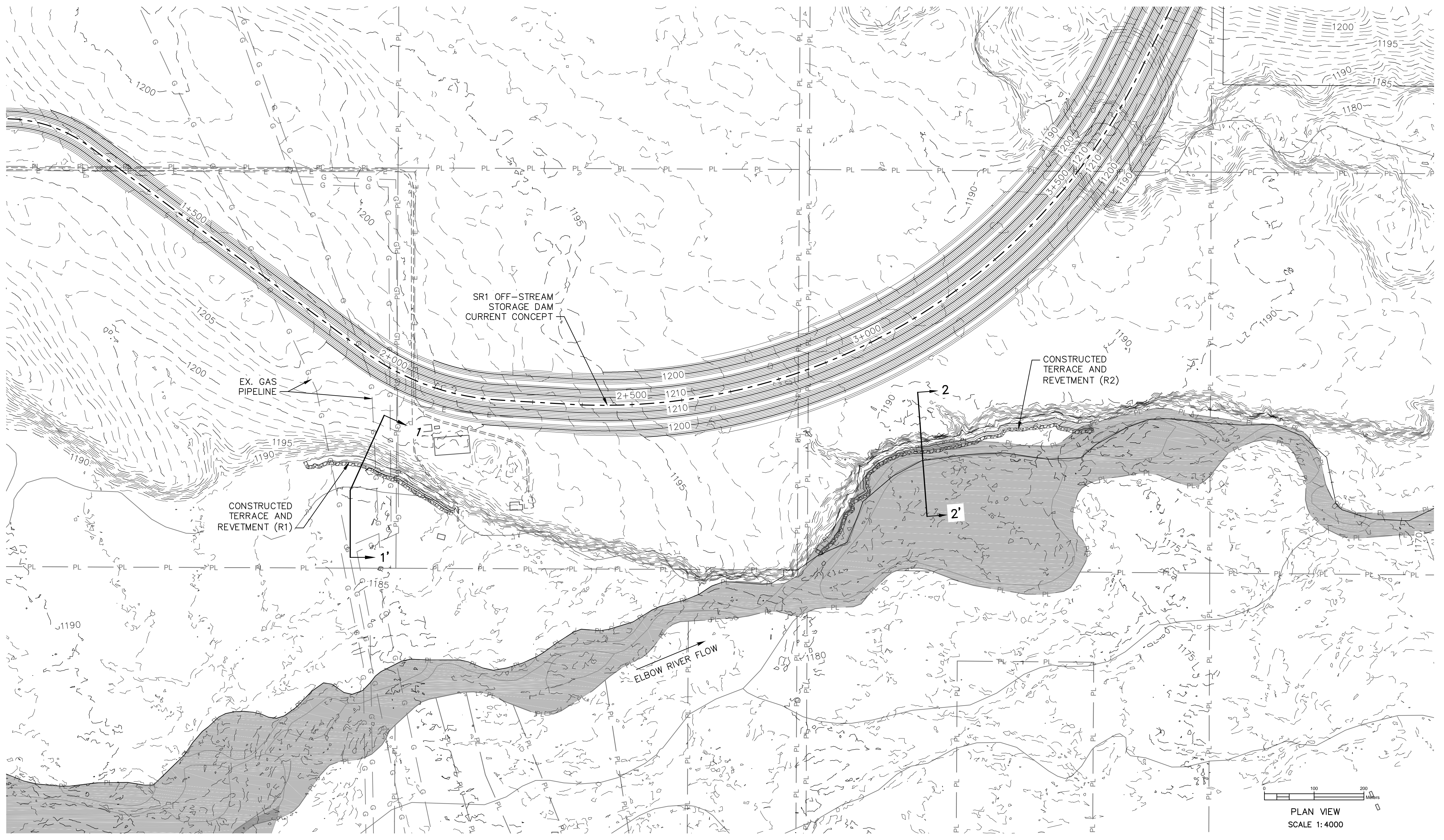

PLAN VIEW
 SCALE 1:4000

THIS DRAWING MAY HAVE BEEN REDUCED.
 ALL SCALE NOTATIONS INDICATED (i.e. 1:1000 etc)
 ARE BASED ON 22" X 34" FORMAT DRAWINGS

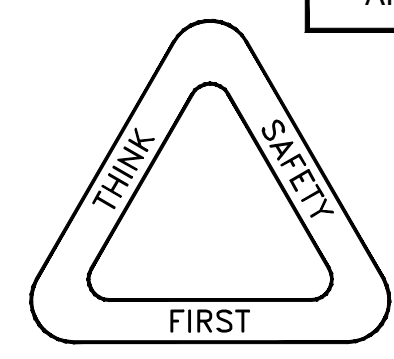

Stantec
 Project No.: 110773396
 200 - 325 25th Street SE
 Calgary AB Canada T2A 7H8
 Tel. 403.716.8000
 www.stantec.com

REV	DATE	REVISIONS	BY

PRELIMINARY - NOT FOR CONSTRUCTION	DESIGNER	CHECKER
	DATE	DATE
DATE	ALBERTA ENVIRONMENT AND PARKS CAPITAL PROJECTS NUMBER	
2016-07-06		

Alberta
 Transportation

SITE
 SR1 - ROCKY VIEW, ALBERTA

SPRINGBANK OFF-STREAM STORAGE PROJECT		
DAM ALIGNMENT AND TOE LOCATION RELATIVE TO THE ELBOW RIVER ATTACHMENT 3-1 RIVER TRAINING STRUCTURES CONCEPT OPTION 2B - PLAN		
SHEET	CONSULTANT DRAWING	TRANSPORTATION DRAWING
5 OF 7		

PlotDate: 2016.07.06 11:11 AM Login: White, Jarred
 AUTOCAD FILE No. U:\110773396\component_work\dams_diversion\civil\drawing\30_percent\text\bits\Dam_Toe_Memo\RIVER_TRAINING_STRUCTURES_2B.dwg TENDER No. ?

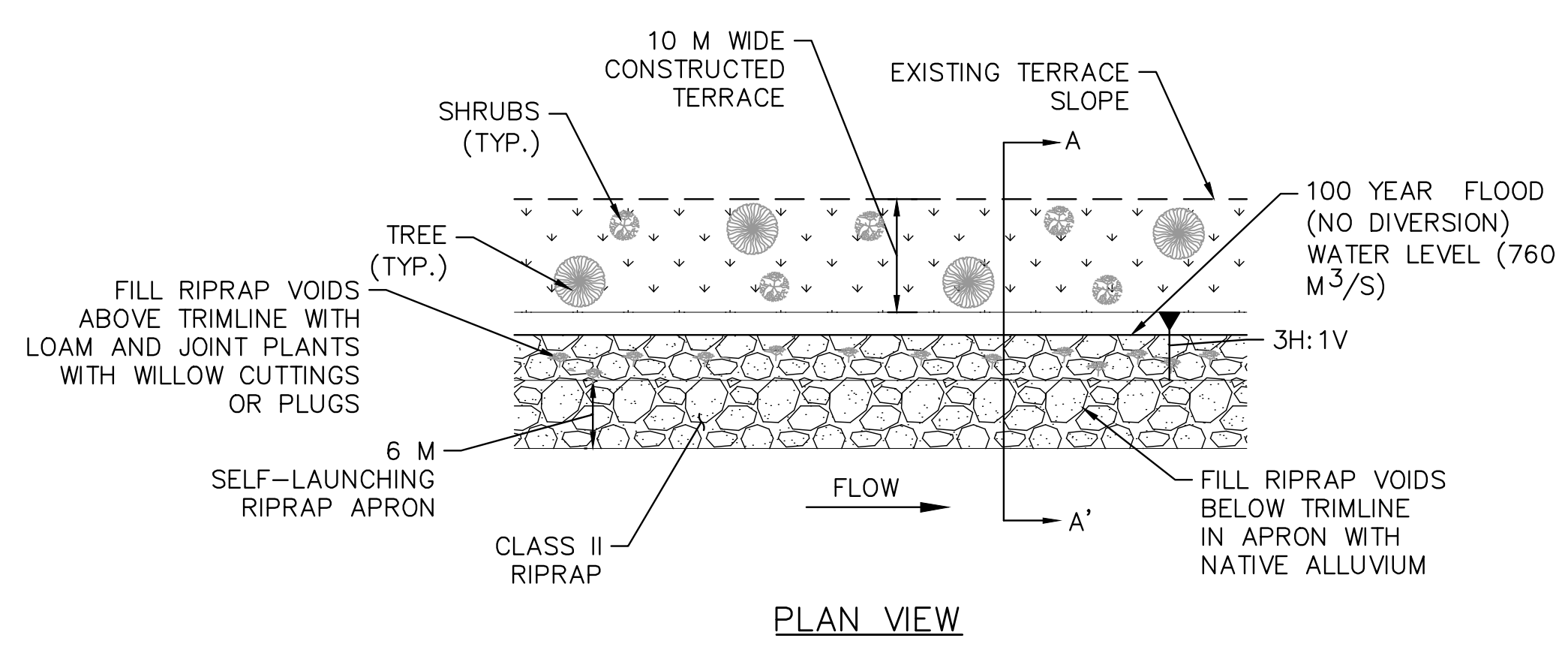
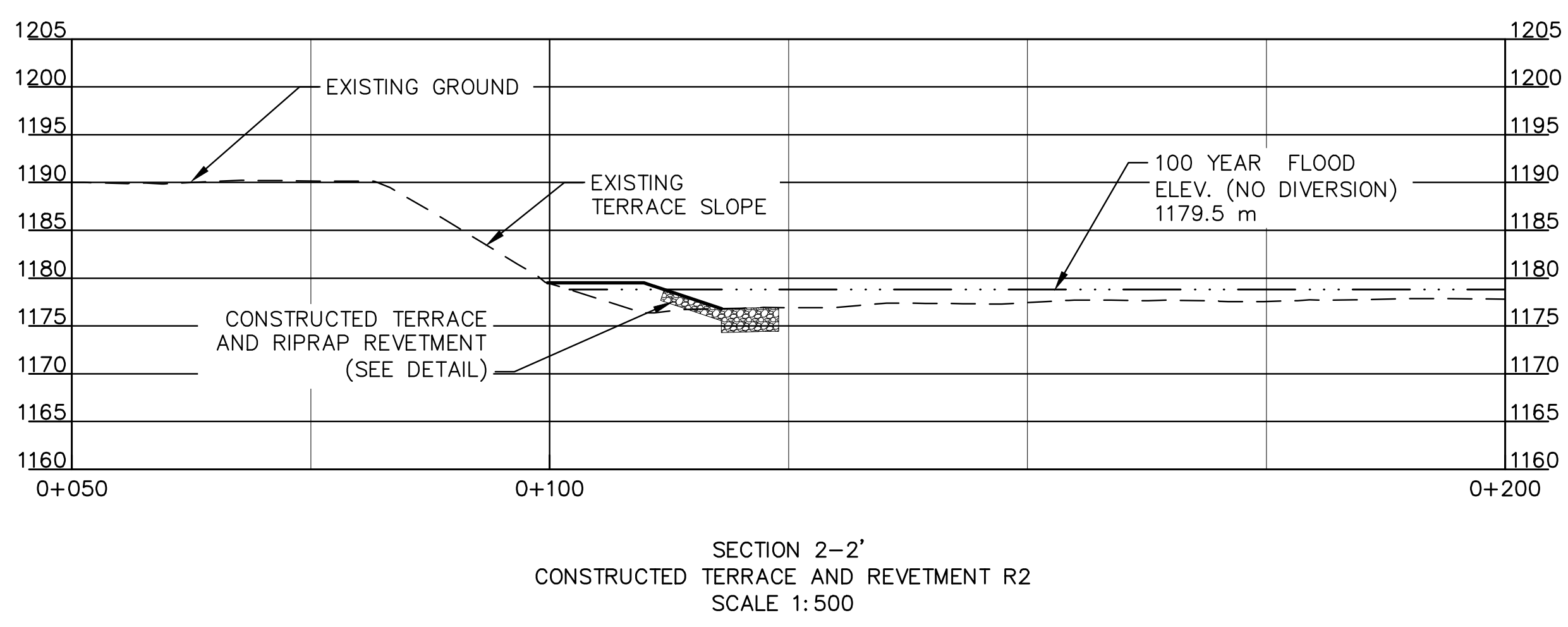
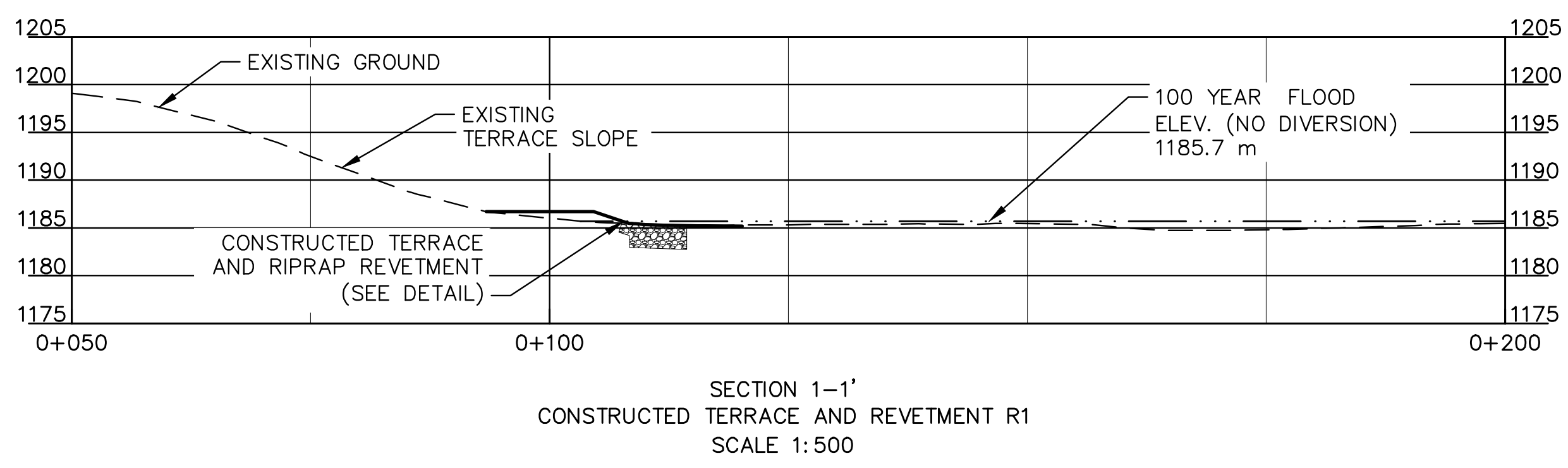

CLASS II RIPRAP GRADATION

% PASSING	STONE SIZE	
	DI. (MM)	MASS (KG)
100	800	700
30-80	600	300
20-50	500	200
5-20	300	40

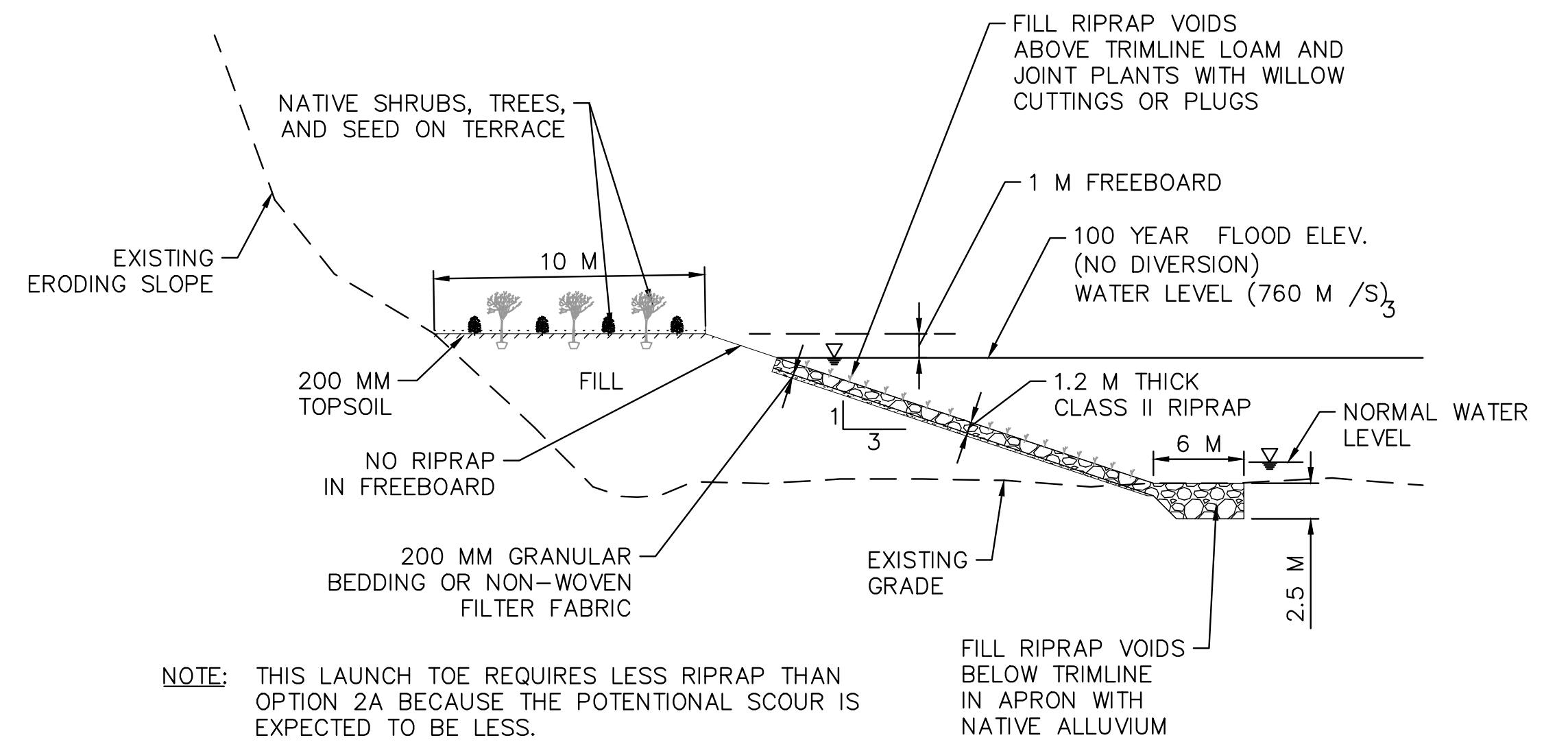

NOTE: THIS LAUNCH TOE REQUIRES LESS RIPRAP THAN OPTION 2A BECAUSE THE POTENTIAL SCOUR IS EXPECTED TO BE LESS.

OPTION 2B
CONSTRUCTED TERRACE AND
REVETMENT DETAIL
 NOT TO SCALE

THIS DRAWING MAY HAVE BEEN REDUCED. ALL SCALE NOTATIONS INDICATED (i.e. 1:1000 etc) ARE BASED ON 22" X 34" FORMAT DRAWINGS

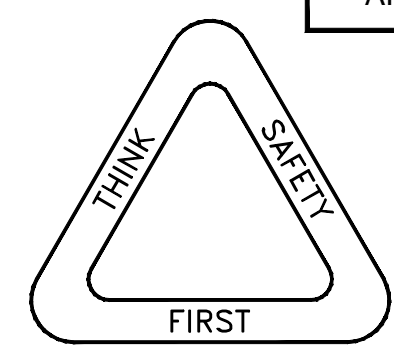

 Project No.: 110773396 200 - 325 25th Street SE Calgary AB Canada T2A 7H8 Tel. 403.716.8000 www.stantec.com	6 5 4 3 2 1 REV	DATE REVISIONS BY	2016-07-06	DESIGNER CHECKER DATE	ALBERTA ENVIRONMENT AND PARKS CAPITAL PROJECTS NUMBER	 SITE SR1 - ROCKY VIEW, ALBERTA	SHEET 6 OF 7	CONSULTANT DRAWING TRANSPORTATION DRAWING
	SPRINGBANK OFF-STREAM STORAGE PROJECT DAM ALIGNMENT AND TOE LOCATION RELATIVE TO THE ELBOW RIVER ATTACHMENT 3-2 RIVER TRAINING STRUCTURES CONCEPT OPTION 2B - SECTIONS AND DETAILS							

PRELIMINARY - NOT FOR CONSTRUCTION

PlotDate: 2016.07.06 11:33 AM Login: White, Jarred
 AUTOCAD FILE No. U:\110773396\component_work\dams_diversion\civil\drawing\30_percent\exhibits\Dam_Toe_Memo\Attach_4_Dam_Alternative.dwg TENDER No. ?

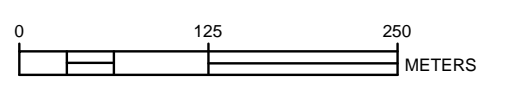
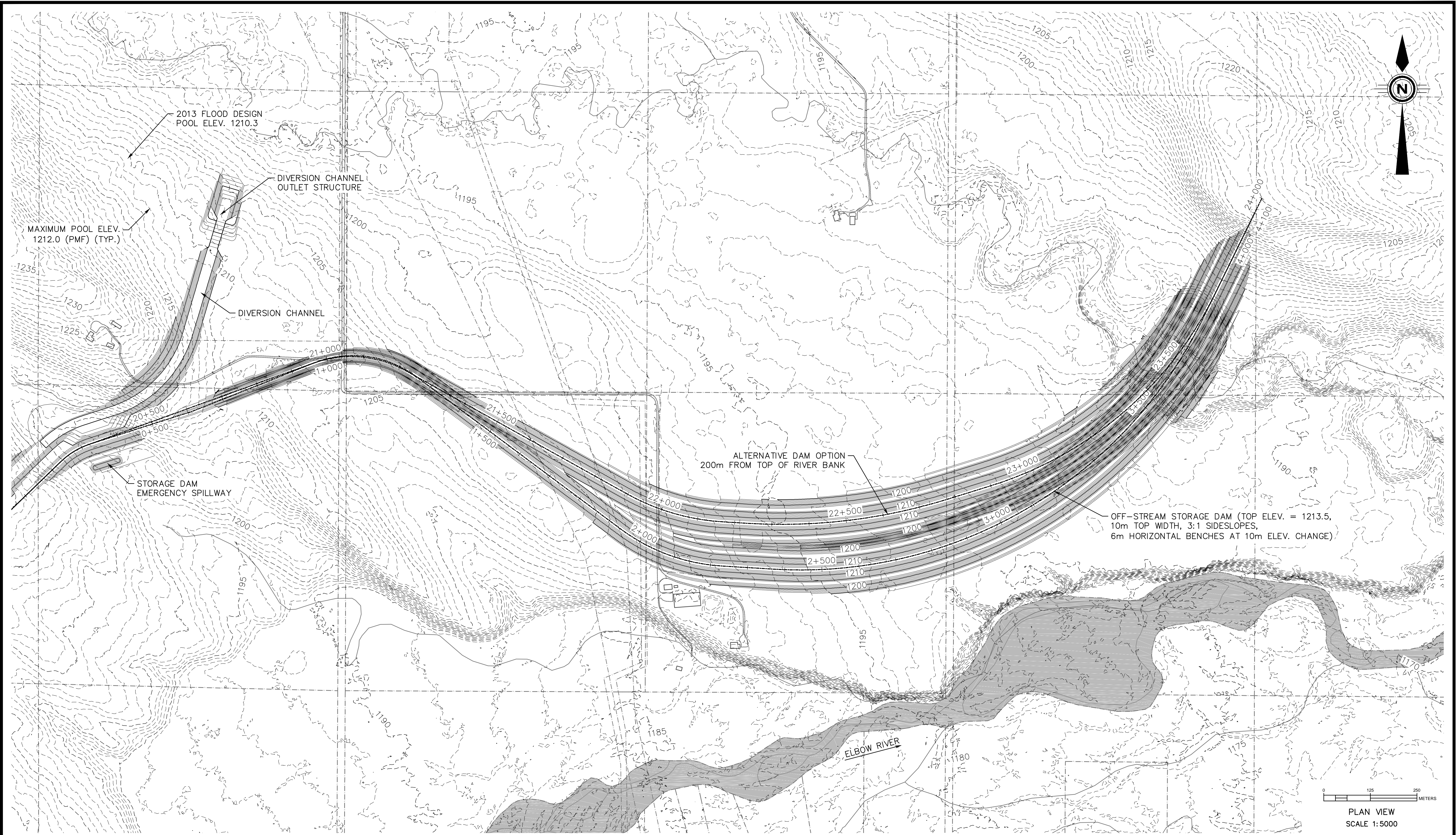

PLAN VIEW
 SCALE 1:5000

THIS DRAWING MAY HAVE BEEN REDUCED.
 ALL SCALE NOTATIONS INDICATED (i.e. 1:1000 etc)
 ARE BASED ON 22" X 34" FORMAT DRAWINGS

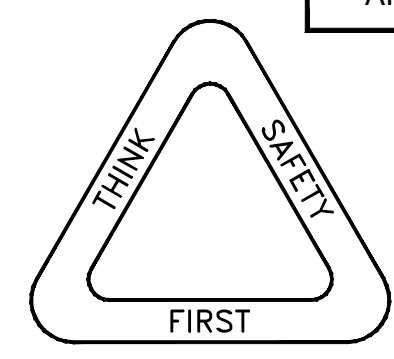

Stantec
 Project No.: 110773396
 200 - 325 25th Street SE
 Calgary AB Canada T2A 7H8
 Tel. 403.716.8000
 www.stantec.com

REV	DATE	REVISIONS	BY

PRELIMINARY - NOT FOR CONSTRUCTION	DESIGNER	CHECKER
	DATE	DATE
DATE	ALBERTA ENVIRONMENT AND PARKS CAPITAL PROJECTS NUMBER	
2016-07-06		

Alberta
 Transportation

SPRINGBANK OFF-STREAM STORAGE PROJECT		
DAM ALIGNMENT AND TOE LOCATION RELATIVE TO THE ELBOW RIVER		
ATTACHMENT 4		
STORAGE DAM REALIGNMENT CONCEPT OPTION 3		
SITE	SHEET	CONSULTANT DRAWING
SR1 - ROCKY VIEW, ALBERTA	7 OF 7	TRANSPORTATION DRAWING