

Traffic Accommodation in Work Zones



TRAFFIC ACCOMMODATION IN WORK ZONES

Date of Issue: May, 1999

2nd Edition: May, 2001

© Copyright, May, 1999

**The Crown in right of the Province of Alberta,
as represented by the Minister of Transportation.**

**Purchasers of this document in hard copy and/or electronic format
are hereby given permission to reproduce all or portion of this document without modification.**

**If changes are made to any of the drawings, it should be made clear that
the drawings have been modified and all appropriate approvals obtained before
the modified drawings are used on a public roadway.**

**Executive Director, Technical Standards Branch
Alberta Transportation**

PREFACE

These guidelines are to be utilized for traffic accommodation through work zones on highways and bridges in Alberta. Continuing comment is essential to the regular updating of this document and any feedback is welcome and may be sent to Director of Highway Engineering, Technical Standards Branch, Alberta Transportation, 4999 – 98 Avenue, Edmonton, Alberta, T6B 2X3.

Much appreciation is expressed to all those who contributed to the development of this document. Special appreciation is expressed to the Consulting Engineers of Alberta (CEA) and Alberta Roadbuilders and Heavy Construction Association (ARHCA) for reviewing and providing comments on draft versions.

TABLE OF CONTENTS

SECTION I. GUIDELINES FOR TRAFFIC ACCOMMODATION

1.	INTRODUCTION	1
2.	DEFINITIONS	1
3.	PRIMARY RESPONSIBILITIES	2
4.	TRAFFIC ACCOMMODATION	6
4.1	GENERAL CONSIDERATIONS	6
4.2	FLAGPERSONS	6
4.3	DETOURS	7
4.4	TEMPORARY SPEED REDUCTIONS	7
4.5	COORDINATION OF ACTIVITIES	7
5.	TRAFFIC ACCOMMODATION STRATEGY	7
5.1	GENERAL	7
5.2	GENERAL CONSIDERATIONS FOR THE TRAFFIC ACCOMMODATION STRATEGY	8
5.3	ESTABLISHING THE TRAFFIC ACCOMMODATION STRATEGY	9
5.4	MONITORING TRAFFIC ACCOMMODATION	10
5.5	DAILY RECORD OF TRAFFIC CONTROL DEVICES	10
6.	COMPLIANCE WITH CONTRACT SPECIFICATIONS AND TRAFFIC ACCOMMODATION STRATEGY ON DEPARTMENT CONSTRUCTION CONTRACTS	11
7.	LONG DURATION PROJECTS	12
8.	SHORT DURATION PROJECTS	13
9.	TRAFFIC CONTROL DEVICES	13
9.1	GENERAL	13
9.2	TEMPORARY SIGNING	14
9.3	TEMPORARY WARNING SIGNS	15
9.4	TEMPORARY REGULATORY SIGNS	15
9.5	INFORMATION (GUIDE) SIGNS	15
9.6	INSTALLATION OF TEMPORARY SIGNS	16
9.7	DELINEATORS	16
9.8	SEQUENTIAL ARROWBOARDS	17
9.9	SPECIALIZED TRAFFIC CONTROL DEVICES	17
9.10	OVERHEAD ILLUMINATION AND FLASHERS	17
10.	TYPICAL DRAWINGS	18

SECTION II. TYPICAL DRAWINGS FOR TEMPORARY CONSTRUCTION SIGNING

1.	LONG DURATION ACTIVITIES
2.	SHORT DURATION ACTIVITIES
3.	TESTING, SURVEY AND OTHER SHORT DURATION ACTIVITIES
4.	MISCELLANEOUS ACTIVITIES
5.	UTILITIES CONSTRUCTION

SECTION III. SAMPLE FORMS

1.	DAILY RECORD OF TEMPORARY CONSTRUCTION SIGNING
----	--

SECTION IV. SIGN SCHEDULE AND SHEETING REQUIREMENTS

SECTION I

**GUIDELINES FOR TRAFFIC
ACCOMMODATION**

TRAFFIC ACCOMMODATION IN WORK ZONES

1. INTRODUCTION

When activities such as roadway/bridge work, utilities work, or materials testing and surveying are performed on or adjacent to public highways in Alberta, the person(s) performing the work must make suitable provisions to safely accommodate the travelling public.

The purpose of this document is to provide information and guidance to the various parties to Alberta Transportation contracts, agreements, permits and authorizations so that the accommodation of traffic is handled in a consistent, safe and effective manner. This document identifies the primary roles and responsibilities of each party for public safety, outlines general considerations for developing an effective traffic accommodation strategy and provides guidelines for the use of various Traffic Control Devices. Also included are a series of drawings detailing minimum temporary signing requirements for typical Work Zones on Alberta Transportation contracts and agreements.

The contents of this document are not intended to modify or supersede any provisions of Alberta Transportation contracts or agreements. In the event of a discrepancy between this document and the Department's contracts or agreements, the requirements of the contract or agreement shall govern.

Users of this manual should note that Section I.6, Compliance with Contract Specifications and Traffic Accommodation Strategy pertains to Alberta Transportation highway/bridge construction projects only. Due to the duration and nature of highway maintenance and utility work, the process used to address incidents of non-compliance may differ for those types of projects.

2. DEFINITIONS

For the purposes of this manual, the following definitions apply:

Department	Alberta Transportation.
Department Representative	The Department official who liaises with the Contractor, Consultant or Utility Company. On Department construction contracts, this person would typically be the "Project Sponsor". On Department maintenance contracts, this person would typically be the Maintenance Contract Inspector (MCI). For Utility work, this person would typically be the Development Planning Technologist.
Consultant	The person(s) retained by the Department to design and/or administer a highway/bridge construction or maintenance contract.
Contractor	The person(s) performing the work on a Department highway/bridge construction or maintenance contract.

Utility Company	The person(s) installing, adjusting, maintaining or relocating a utility within the highway right-of-way.
Work Zone	The area extending from the “Construction Ahead” sign to the “End of Construction” sign.
Work Area	The area or location of the actual traffic disruption or hazard. (There may be several Work Areas within the Work Zone.)
Traffic Accommodation Strategy	Plans and written procedures detailing the traffic accommodation activities for the project.
Traffic Control Devices	Temporary signing, traffic control signals, arrowboards, pavement markings, delineators, message boards, etc., used for traffic accommodation in the Work Zone.
Specifications	The latest editions of Alberta Transportation's Standard Specifications for Highway Construction or Standard Specifications for Bridge Construction or Highway Maintenance Specifications as applicable.

3. PRIMARY RESPONSIBILITIES

To ensure traffic accommodation is handled in a consistent, safe and effective manner, it is critical that all parties to Alberta Transportation’s contracts, agreements, permits and authorizations carry out their respective responsibilities concerning traffic accommodation.

The primary responsibilities of the Contractor, Consultant, Utility Company and the Department for traffic accommodation are as follows:

A. Contractor

The following are the Contractor's primary responsibilities for traffic accommodation on Department highway/bridge construction and maintenance contracts.

On construction projects, any required submissions or reporting by the Contractor shall be directed to the Consultant. On maintenance projects, any required submissions or reporting by the Contractor shall be directed to the Department Representative.

- Develop a Traffic Accommodation Strategy and submit it for evaluation prior to commencement of the work.
- Implement traffic accommodation measures in accordance with the Traffic Accommodation Strategy.
- Ensure that all sub-contractors comply with the Traffic Accommodation Strategy.

- Monitor the Work Zone to ensure that the Traffic Accommodation Strategy is effective for both daytime and nighttime conditions during periods of construction and shut down.
- Maintain all Traffic Control Devices.
- Modify the Traffic Accommodation Strategy as necessary.
- Take appropriate and timely action to correct any deficiencies identified by the Contractor, the Consultant or the Department. In cases of imminent danger, corrective action must be immediate.
- Report all third party vehicle accidents immediately. Provide a copy of the completed accident report within 72 hours of the occurrence.
- On construction projects, submit completed daily reports of traffic accommodation details (location, date, time, signs, barricades, etc.) on a weekly basis.
- On construction projects, attend any meetings initiated by the Consultant to address any concerns regarding the performance of the Traffic Accommodation Strategy.
- On construction projects, submit a timely and accurate schedule of the sub-contractors activities prior to commencement of the work.
- Provide a knowledgeable individual at the Work Zone to maintain the Traffic Control Devices and address any traffic accommodation issues which arise. On construction projects, the Contractor must identify this individual at the pre-construction meeting.

B. Consultant

The following are the Consultant's primary responsibilities for traffic accommodation, when administering a Department highway/bridge construction contract.

When a Consultant performs work such as survey and materials testing within the highway right-of-way which does not coincide with the Contractor's activities, the primary responsibilities of the Contractor shall also apply to the Consultant.

- Identify in the special provisions of a construction contract, any unique situations that will require special traffic accommodation measures. Ensure the Contractor addresses these situations in the Traffic Accommodation Strategy (eg. limiting the length of the Work Zone, establishing the posted speed for the Work Zone, etc.).
- Where applicable, confirm "traffic counts" with the Department Representative and include this information in the special provisions for the contract (several drawings contained in this document require additional Traffic Control Devices for certain traffic volumes).
- Where applicable, confirm requirements for overhead illumination for the Work Area (other than flagperson stations) with the Department Representative and include any requirements in the special provisions for the contract.
- Provide suitable traffic accommodation for the Consultant's activities and coordinate the positioning of the Consultant's Traffic Control Devices with the Contractor and/or Utility Company when necessary.
- Review the Contractor's Traffic Accommodation Strategy prior to commencement of the work to determine if it is appropriate for the site conditions anticipated.

- Provide a copy of the Contractor's Traffic Accommodation Strategy to the Department Representative.
- Liaise with the Contractor to address any concerns with the proposed Traffic Accommodation Strategy.
- Notify the local RCMP of the proposed changes to traffic flow. Invite the RCMP to review traffic flows, signage and any other Traffic Control Devices upon commencement of the work.
- Where applicable, notify local fire department and ambulance service of the impending work and anticipated site conditions.
- Provide the Department Representative with a completed "Order Fixing Maximum Speed Limits" prior to commencement of the work.
- Periodically monitor the Work Zone to ensure the Contractor implements and maintains the Traffic Accommodation Strategy.
- Monitor the Work Zone as the Consultant deems necessary and as the work progresses to determine if the Traffic Accommodation Strategy is suitable for each phase of the work and throughout the duration of the project.
- Initiate any meetings required with the Contractor to address any concerns regarding the performance of the Traffic Accommodation Strategy.
- Advise the Contractor of any deficiencies in his traffic accommodation measures and ensure that the Contractor takes appropriate and timely corrective action.
- Order the Contractor to suspend work in cases of recognized imminent danger or where the Contractor fails to undertake appropriate and timely measures to accommodate traffic or fails to correct recurring deficiencies. Immediately notify the Department Representative in cases where such orders are issued.
- Immediately notify the Department Representative of any accidents which involve a fatality, serious personal injury, or 3rd party property damage in excess of \$1,000 or as specified in the Motor Vehicle Administration Act or any act or regulation that replaces the Motor Vehicle Administration Act Provisions. Provide the Department Representative with a Construction Zone Accident Report within 72 hours of knowledge of the accident. (Report to include photos, details of site conditions, record of signs, etc.)
- Review all daily traffic reports received from the Contractor.

C. Utility Company

- When performing work in conjunction with a Department construction contract and inside the Contractor's Work Zone, provide suitable Traffic Control Devices for the utility work and co-ordinate the positioning of these devices with the Contractor and Consultant.
- When performing work which is not inside the Contractor's Work Zone, develop a Traffic Accommodation Strategy and submit it to the Department Representative for evaluation prior to commencement of the work.
- Provide a knowledgeable individual at the utility Work Area to maintain the Traffic Control Devices and address any traffic issues which arise. Identify this individual to the Department Representative prior to commencement of the work.

- Implement traffic accommodation measures in accordance with Traffic Accommodation Strategy.
- Monitor the utility Work Area to ensure the Traffic Accommodation Strategy is effective. Modify the Strategy when necessary and advise the Department Representative accordingly.
- Maintain all Traffic Control Devices.
- Take appropriate and timely action to correct any deficiencies.
- Ensure that all sub-contractors working for the Utility Company comply with the Traffic Accommodation Strategy.
- Report all third party vehicle accidents to the Department Representative immediately. Provide a copy of the completed accident report within 72 hours of the occurrence.

D. Department

The Department establishes standards for the specifications and typical drawings and ensures that public safety is a high priority on Department construction and maintenance contracts and utility work. In addition, the Department performs the following functions:

(i) On projects where the Department has retained a Consultant to administer the project

- At the design stage of the project, provide the Consultant with comments regarding the proposed traffic accommodation procedures and assist in the identification of issues that are unique to the project.
- Provide comments to the Consultant concerning the Contractor's proposed Traffic Accommodation Strategy.
- May periodically visit the Work Zone. During such visits, advise the Consultant of any deficiencies noted in the traffic accommodation measures.
- Order the Contractor to suspend work in cases of recognized imminent danger or where the Contractor fails to take appropriate and timely measures to accommodate traffic. Typically, the Department would only take on this responsibility during a "periodic visit" where the Consultant cannot be contacted to issue the order to suspend work.
- Review Construction Zone Collision reports for completeness and report any traffic accommodation signing deficiencies noted to the Consultant so that they can be corrected immediately.

(ii) On projects where the Department has not retained a Consultant to administer the project

- Review the Traffic Accommodation Strategy prior to commencement of the work to determine if it is appropriate for the site conditions anticipated.
- Liaise with the person performing the work to address any concerns with the proposed Traffic Accommodation Strategy.

- Periodically monitor the Work Zone to ensure the person performing the work implements and maintains the Traffic Accommodation Strategy.
- Monitor the Work Zone as the Department deems necessary and as the work progresses to determine if the Traffic Accommodation Strategy is suitable for each phase of the work and throughout the duration of the project.
- Initiate any meetings required with the Contractor to address any concerns regarding the performance of the Traffic Accommodation Strategy.
- Advise the person performing the work of any deficiencies in his traffic accommodation measures and ensure that the Contractor takes appropriate and timely corrective action.
- Order the person performing the work to suspend work in cases of recognized imminent danger or where he fails to undertake appropriate and timely measures to accommodate traffic or fails to correct recurring deficiencies. Immediately notify the Department Representative in cases where such orders are issued.
- For any accidents, which involve a fatality, serious personal injury, or 3rd party property damage in excess of \$1,000 or as specified in the Motor Vehicle Administration Act, or any act or regulation that replaces the Motor Vehicle Administration Act Provisions, complete a Construction Zone Accident Report within 72 hours of knowledge of the accident. (Report to include photos, details of site conditions, record of signs, etc.)

4. TRAFFIC ACCOMMODATION

4.1 GENERAL CONSIDERATIONS

In addition to providing safe passage for traffic through the Work Zone, effective traffic accommodation involves minimizing inconvenience to traffic. To ensure traffic moves effectively through the Work Zone, it is critical that the Traffic Control Devices (TCD's) used to advise, warn and direct traffic are appropriate for the site conditions. Any TCD's which are not required must be removed or covered immediately.

In all cases, any required TCD's, flagpersons and detours must be in place prior to the commencement of the work. In addition, the required minimum lane width must be maintained at all times.

4.2 FLAGPERSONS

In situations where the sole use of TCD's does not provide sufficient warning or direction to traffic, the use of flagpersons may be required. The proper use of flagpersons to control and direct the flow of traffic can mitigate problems inherent in congested Work Areas and in Work Areas involving reduced lane widths and lane closures. When traffic queues occur, additional flagpersons and/or repositioning of the "Flagperson Ahead" sign may be necessary. All flagpersons must be certified in accordance with the requirements outlined in the contract, agreement, permit or authorization..

4.3 DETOURS

In situations where it is necessary to close the entire roadway, a detour must be provided. The scheduling, location and use of a detour requires prior approval of the Department and/or other jurisdictions.

Where the conditions dictate that construction of a detour is necessary, the Contractor shall design the detour in accordance with the temporary highway detour geometric guidelines contained in the latest edition of the Department manual entitled Highway Geometric Design Guide and also the drawings contained in this document.

4.4 TEMPORARY SPEED REDUCTIONS

When work is performed within the highway right-of-way on Department contracts or agreements, the Department has the authority, under the Highway Traffic Act, to authorize temporary speed reductions in the Work Zones.

On Long Duration construction projects, the Department ensures local authorities are aware of the temporary speed reduction by requiring the Consultant to complete the "Order Fixing Maximum Speed" form.

On Short Duration utility work or highway maintenance projects, the form is not required as the Work Zone is often mobile and/or in place for less than a day.

4.5 COORDINATION OF ACTIVITIES

On Department construction projects, it is not uncommon to have the Contractor, Consultant, and/or Utility Company simultaneously performing work within the Contractor's Work Zone. In these situations, it is important that traffic accommodation is a coordinated effort between all parties and that the positioning of Traffic Control Devices required for each activity is established prior to commencement of the work.

5. TRAFFIC ACCOMMODATION STRATEGY

5.1 GENERAL

When activities are performed on or adjacent to the roadway which disrupt the normal flow of traffic, a Traffic Accommodation Strategy is required. A Traffic Accommodation Strategy consists of plans and written procedures which address the traffic accommodation issues relevant to the specific activity being performed. To be effective, the Traffic Accommodation Strategy must provide road users with adequate warning of the activity being performed, protection for workers and equipment within the Work Area and allow traffic to pass safely through the Work Zone.

For work performed by a Contractor on a Department construction or highway maintenance contract, the Traffic Accommodation Strategy shall be developed by the Contractor.

For work performed by a Utility Company (outside the limits of the Contractor's Work Zone), a Traffic Accommodation Strategy shall be developed by the Utility Company.

For work performed by a Consultant (outside the limits of the Contractor's Work Zone), a Traffic Accommodation Strategy shall be developed by the Consultant.

On construction contracts, the Contractor must submit the Traffic Accommodation Strategy to the Consultant prior to commencement of the work and in sufficient time to allow the Consultant to evaluate the suitability of the proposed strategy. The Consultant will then review the Traffic Accommodation Strategy and address any concerns with the Contractor. The timelines for the submission and review of the Traffic Accommodation Strategy are detailed in the Specifications.

On highway maintenance contracts, Traffic Accommodation Strategies for "planned" maintenance activities shall be submitted by the Contractor to the Department Representative for review prior to commencement of the work and in accordance with the Specifications.

For "non-planned" maintenance activities or emergency situations it may not be practical to develop a site-specific Traffic Accommodation Strategy. For these cases, typical or generic strategy(s) which generally cover the activities or situations anticipated, may be used. These "generic" strategies must also be in place prior to commencement of the work.

When a Traffic Accommodation Strategy for work performed by a Consultant or Utility Company is required, the Consultant or Utility Company shall submit the strategy within the timelines established by the Department Representative.

To achieve consistency in the accommodation of traffic on Department projects, the guidelines and plans contained in this document must always be considered when developing or evaluating a Traffic Accommodation Strategy. The guidelines and plans contain minimum standards for typical conditions. However, the actual requirements for traffic accommodation at the Work Zone may vary depending on the complexity of the work activity, traffic volumes, traffic speeds, night time conditions, highway geometrics and other site specific conditions.

5.2 GENERAL CONSIDERATIONS FOR THE TRAFFIC ACCOMMODATION STRATEGY

The objective of a Traffic Accommodation Strategy is to safely accommodate both the road users passing through the Work Zone and the workers performing activities within the Work Zone. The complexity of the Traffic Accommodation Strategy will vary depending upon a number of factors including traffic volumes and the nature of the activity being performed. Typically, traffic accommodation measures required for Long Duration projects will be more elaborate than those for Short Duration projects.

Regardless of the nature of the activity, the following factors should be considered when developing the Traffic Accommodation Strategy:

- Duration of work.
- Traffic volumes (AADT, ASDT, peak hours, statutory holidays, special events and recreation traffic, etc.).
- Class of roadway (capacity, level of service, etc.).
- Available sight distance.
- Intersecting roadways.
- Gradeline (steep hills create stopping problem).
- Type of roadway surface (gravel or paved).
- The use of only those Traffic Control Devices which are necessary to clearly warn, advise and control the traffic.
- Speed limits must be appropriate for the conditions. When reductions in speed are necessary, the speed must be reduced over a reasonable distance.
- The provision of a buffer between traffic and workers whenever possible.
- Occupational Health and Safety legislation pertaining to clothing, hardhats, etc., to be worn by workers.
- Devices used to delineate the travel lanes must be appropriate for the intended purpose. Such devices must be visible to traffic and positioned and spaced in a manner which will optimize their effectiveness.
- Stabilizing Traffic Control Devices with weights when necessary.
- Closing only those lanes necessary to divert traffic around workers and/or equipment.
- The use of flags and/or flashers to increase the visibility or prominence of signs.
- The use of flagpersons for traffic control.
- The effect of restricted traffic flow on “upstream” conditions (traffic congestion, etc.).
- Avoid scheduling operations during hours of peak traffic volumes.
- The requirements as illustrated on the typical drawings included in this document pertaining to the use and location of tapers and transitions.
- Weather conditions (dust, rain or snow).
- Site specific safety issues.

5.3 ESTABLISHING THE TRAFFIC ACCOMMODATION STRATEGY

It is extremely important that all parties have a clear understanding of how traffic will be accommodated before work commences. This information must be detailed in the Traffic Accommodation Strategy.

The Traffic Accommodation Strategy must contain drawings detailing the configuration of temporary signing and any other Traffic Control Devices which will be used to accommodate traffic. For typical situations, the drawings contained in this document may be used. For non- typical situations, site specific or activity specific drawings must be developed by the person performing the work.

The Traffic Accommodation Strategy must also document procedures which will be used to address specific issues such as:

- Installing, relocating and removing Traffic Control Devices.

- Accommodating wide or long vehicles.
- Accommodating vehicles around fresh tack coat.
- Sequential installation and implementation and removal of the Traffic Control Devices.
- Night time and other periods of inactivity.
- Use of detours.
- Accommodating emergency vehicles.
- The use of non-typical lane widths.
- The on-site designate responsible for traffic accommodation.
- Any non-typical situations not covered by the drawings.

It is critical that all parties are in agreement on the procedures, signing configurations, and Traffic Control Devices to be used for the accommodation of traffic prior to commencement of the work. Once work commences, changes can be made as conditions dictate. Any change made to the Traffic Accommodation Strategy including the reasons or circumstances necessitating the change must be documented in writing.

5.4 MONITORING TRAFFIC ACCOMMODATION

To ensure traffic control measures are performing as intended, it is necessary to monitor and maintain the TCD's on a regular basis. The person performing the work designates a specific individual to perform this function and ensure any issues arising are addressed in a consistent and timely manner. To be effective in this role, such individuals must be knowledgeable in the processes and procedures for accommodating traffic including the use of all types of TCD's.

5.5 DAILY RECORD OF TRAFFIC CONTROL DEVICES

The person performing the work must document specific information concerning the temporary construction signing and any other Traffic Control Devices used to accommodate traffic through the Work Area. This information is recorded each day, as the work area changes and for the entire duration of the project. A sample form is included in this document. The person performing the work may develop and use his own form provided it clearly contains all the information shown on the sample form.

Information to be recorded includes the following:

- Project description.
- Date and time the Traffic Control Devices were inspected by the Contractor.
- Station number of the beginning of each Work Area.
- Designation and location (station number) of the temporary construction sign immediately prior to each Work Area.
- "Reference number" of the signing drawing which reflects the temporary construction signing existing at the time of the inspection. Typically, the drawing referenced will be one which forms part of the Traffic Accommodation Strategy.

- Any significant issues concerning the signing, including any variations between the actual signing and that which is shown on the signing drawing. This information should be noted in the “comments” section of the form.

As a minimum, the signing should be inspected and the information recorded for each Work Area, at the commencement of work each day and any other times throughout the day when the signs are moved or changed.

Recording this information does not relieve the person performing the work of his responsibility to ensure that the traffic accommodation activities comply with Traffic Accommodation Strategy at all times during the project.

6. COMPLIANCE WITH CONTRACT SPECIFICATIONS AND TRAFFIC ACCOMMODATION STRATEGY ON DEPARTMENT CONSTRUCTION CONTRACTS

It is the Department's expectation that the Contractor complies with the Specifications for traffic accommodation and the Traffic Accommodation Strategy at all times throughout the duration of the project. In situations where the Contractor is not in compliance with these requirements, the Consultant has the authority to order the Contractor to suspend work on the project. Although ordering the immediate suspension of work will ultimately achieve compliance with the Specifications, it may not be practical or desirable to take this course of action in all cases. Therefore, to ensure proper administration of this authority the Consultant must exercise good judgement in each case.

In a situation where there is recognized imminent danger to road users, the suspension of work must be immediate and must continue until the Contractor has rectified the deficiency to the satisfaction of the Consultant.

When an infraction or deficiency is considered to be minor and does not result in imminent danger, an escalating resolution process should be used.

In these cases, the Consultant's first attempt to have the issue resolved should be through verbal communication with the Contractor. At this stage, it may be beneficial for the Consultant to meet with the Contractor, identify or explain the nature of the deficiency, confirm expectations and discuss possible solutions to help prevent a reoccurrence of the deficiency.

If the infraction or some similar type of deficiency reoccurs, the Consultant must issue a written warning, advising the Contractor that continued infractions will result in the issuance of an order to suspend work on the project. A copy of this written warning must be forwarded to the Contractor's head office and the Project Sponsor. At this point the Contractor should examine his existing methods or processes for accommodating traffic and consider making modifications which will prevent reoccurring infractions and ensure compliance with the Specifications. The nature of the methods or processes required to ensure compliance with the Specifications is totally the responsibility of the Contractor.

If after the issuance of a written warning infractions continue to occur, the Consultant must issue the Contractor with a written order to suspend work on the project. At this point, the Project Sponsor must be notified of the conditions at the Work Zone and the Contractor's failure to comply with the contract requirements.

When a written order to suspend work is issued, the "order" may cover a specific phase of the work (being performed by a sub-contractor) or the entire project, as actual conditions dictate. In all cases, the Contractor is totally accountable for the performance of his sub-contractors.

The written order to suspend work remains in effect until the Contractor rectifies the deficiency. Further, when an order to suspend work has been issued, it is recommended that the Consultant arrange a meeting between himself, the Project Sponsor, and senior official of the Contractor to discuss the problems associated with traffic accommodation on the project and to establish measures which will prevent future occurrences of non-compliance.

It is the Department's intent and expectation that in all cases, deficiencies in traffic accommodation are addressed in a prompt and effective manner. Therefore, this escalating resolution process may culminate over a period of days or within a single day, depending on the nature of the deficiency.

Repeated non-compliance by Contractors on previous Department projects may require that alternative measures be used to ensure effective traffic accommodation. In these cases, the Project Sponsor should confirm expectations and the manner in which non-compliance will be handled with the Consultant and the Contractor prior to commencement of the work.

7. LONG DURATION PROJECTS

Generally, Long Duration projects involve activities such as the construction of a new roadway or bridge, the reconstruction or resurfacing of an existing roadway and other similar types of work. These projects may have a duration of anywhere from one or two weeks to several months. The work generally requires the use of a large fleet of heavy equipment working in relatively long Work Zones, on and adjacent to the roadway surface.

Due to the varying duration and site conditions and the complexity of these types of projects, a unique Traffic Accommodation Strategy is required in each instance. When developing a Traffic Accommodation Strategy for a Long Duration project, the following additional factors must be considered:

- Type of activity (mobile versus stationary).
- Other work planned adjacent to or within the project limits.
- Railway crossings.
- Maintaining traffic control during periods of inactivity (off-hours, downtime, seasonal shutdown, etc.).
- Bridge sites.

Drawings are included for 2 and 4 lane highways illustrating typical minimum requirements for lane closures on Long Duration Projects. Drawings showing typical minimum requirements for specific types of activities such as seal coat work, survey and utility work are also included in this document.

8. SHORT DURATION PROJECTS

Typically, a Short Duration project is a project which does not require an overnight traffic disruption.

Short Duration projects generally involve activities necessary to preserve or repair existing highways and bridges, to perform testing on existing roadway surfaces or to perform survey measurements within the highway right-of-way. Due to the nature of these activities, the work may be performed in accordance with a scheduled plan similar to Long Duration projects or, on an emergency (unscheduled) basis. Short Duration projects may have mobile or stationary Work Areas and may involve work on the highway travel lanes, the highway shoulders, in the highway right-of-way and on or around drainage facilities.

Drawings are included in this document showing typical minimum requirements on Short Duration projects for the following types of situations:

- 2 lane undivided highway (one lane closed for repair)
- 4 lane divided highway (one lane closed for repair)
- 6 lane divided highway (left lane, center lane or right lane closed for repair)
- Repair work on or off shoulder
- Road top shaping

9. TRAFFIC CONTROL DEVICES

9.1 GENERAL

To accommodate traffic safely and effectively, the use of TCD's in Work Zones must achieve the following:

A. Awareness and Identification

- Advise road users of the type of activity they will encounter.
- Divert traffic from its normal path when necessary.
- Advise road users when it is safe to resume normal speed.

B. Protection

- Protect road users and workers from collisions by providing adequate warning and/or a barrier. Where access to a road is being denied to the public, a minimum of 1 barricade for each lane shall be used.

C. Changes in Traffic Speeds

- Generally at locations where the Work results in a change to the existing road conditions (i.e. lane transitions, reduced lane widths, detours), creates obstructions or requires the presence of workers/equipment in or adjacent to the normal path of travel, a reduced speed zone is warranted. Speeds shall be appropriate for accommodating traffic safely through or around the Work Zone with a minimum of inconvenience.
- The “Maximum 50 km/h Passing Workers” sign is used when workers are on the roadway surface for Short Duration work on 2-lane undivided highways only.

D. Lane Delineation

- Provide adequate transitions for the speed and volume of the traffic travelling through the Work Zone.

9.2 TEMPORARY SIGNING

Temporary signing is necessary to accommodate traffic through the Work Zone. The various types of temporary signing generally used includes temporary warning signs, temporary regulatory signs and information signs. Temporary signs must conform to the specifications for shape, color, reflectivity and size. The type, configuration and number of temporary signs required for the Work Zone may vary depending on the nature of the activity and site conditions.

The following factors should be considered when establishing temporary signing:

- Changes to the Work Zone which temporarily or permanently affect signing requirements (covering or removing unnecessary signs, adding additional signs or moving signs).
- Positioning of the signs relative to the travel lane (distance from and height above the travel lane).
- Visibility of the signs (sight distance, vegetation, parked equipment, darkness, dust, etc., which may reduce effectiveness of the signs).
- Signing is required for both sides (in same direction) on multi-lane divided highways.
- Positioning of signs relative to the Work Area.
- Sign spacing. Higher speeds require longer spacing between signs.
- The distance between the “reduced speed” sign and the start of the Work Area. This distance will depend on the reduced speed posted. To be effective, the speed and distance used must allow traffic sufficient time to react without creating undue inconvenience.

Once all necessary temporary signs are in place and traffic is passing through the Work Zone, it is extremely important to monitor the Work Zone on a regular basis to ensure that:

- The signing is performing as intended.

- Maintenance of signs is completed in a timely fashion. (replacing damaged signs, repositioning signs, cleaning signs, re-erecting fallen signs, etc.)
- The signing continues to reflect and address the current site conditions.

9.3 TEMPORARY WARNING SIGNS

Temporary warning signs are used to notify road users of specific hazards that may be encountered in the Work Area. If road users are properly alerted to the changing conditions, they can react in sufficient time to pass safely through the Work Zone.

Some examples of temporary warning signs are:

- Road Work
- Flag person ahead
- Survey Crew
- Pavement Drop-off
- Begin Detour 300 m

9.4 TEMPORARY REGULATORY SIGNS

Temporary regulatory signs are used to direct road users in the Work Zone. Regulatory signs impose legal obligations on all traffic. For example, temporary intersections or intersections having temporarily altered traffic patterns, may require stop signs.

Some examples of temporary regulatory signs are:

- One-Way Traffic
- Two-Way Traffic
- Do Not Pass
- Maximum Speed Ahead
- Maximum Speed When Passing Workers

9.5 INFORMATION (GUIDE) SIGNS

In certain situations, it may be desirable to use information signs to supplement the warning and regulatory signs. For example, detour guide signs and route markers may be used to advise and direct traffic to alternate routes, even though the Work Area is not closed to traffic. There are also special information signs relating to certain types of activities.

9.6 INSTALLATION OF TEMPORARY SIGNS

Temporary signs must be erected such that the face of the sign is clearly visible to oncoming traffic. On 2-lane undivided highways, the signs must be located on the right hand side of the road. On multilane divided highways, signs must be located on both sides of the road.

For construction projects, "Road/Bridge Construction" warning sign shall be mounted on posts and erected approximately 2 km in advance of the project limits. The "Construction Ahead" sign shall be mounted on a post and shall be positioned at the start of the Work Zone.

All other temporary signs may be mounted on posts or on portable stands. Generally, posts are used on Long Duration projects where the Work Area is stationary. The use of portable stands is better suited for situations where the Work Area is mobile or where the duration of work is relatively short. Portable stands shall not be used for planned overnight activities.

The position of all signs relative to the roadway surface must conform with the Specifications. The posts and portable stands on which the signs are installed and any objects used to stabilize the portable stands must not present a hazard to traffic. (e.g. Posts stands and weights used to stabilize TCD's must be "industry standard").

In situations where it is necessary to make specific temporary signs more prominent, attaching flags and/or flashers may be appropriate.

9.7 DELINEATORS

Delineators are used to outline lane transitions and indicate the intended path for road users passing through the Work Area. Effective delineation can be achieved through the use of chevrons, plastic drums, traffic cones (including tubular delineators) or other similar devices. Delineators are not to be used without the appropriate advance warning signage.

To be effective, delineators must be reflectorized and the proper size. When traffic cones are used, the size required is dependant on traffic speed. For speeds greater than 50 km/hr, traffic cones must be a minimum of 70 cm in height. For speeds 50 km/hr or less, the height of the traffic cones must be a minimum of 45 cm.

Typical situations where delineators are used:

- Lane closure
- Lane closure tapers
- Shoulder closure tapers
- Downstream tapers
- To separate opposing lanes of traffic
- To identify temporary hazardous conditions (vertical cuts on roadway shoulders, etc.)

- Detours

9.8 SEQUENTIAL ARROWBOARDS

In certain situations for lane closures on multi-lane highways, sequential arrowboards are used. Arrowboards must always be used in conjunction with other TCD's.

Sequential Arrowboards are very effective for:

- Providing traffic with positive guidance for passing to the left or right of the work area.
- Encouraging traffic to leave the closed lane well in advance of the work area.
- Providing additional advance warning.

Sequential Arrowboards must not be used on highways with “opposing” traffic.

9.9 SPECIALIZED TRAFFIC CONTROL DEVICES

There are several other TCD's that can be used to supplement standard traffic control measures. These devices are generally used in unique situations or for specific activities (e.g. extremely high traffic volumes, seal coat projects, etc.).

Examples of Specialized Traffic Control Devices are:

- Electronic Message Boards
- Rumble Strips (Rope or Mat Type)
- Special information signs developed for unique projects
- Pilot vehicles
- Flagpersons

9.10 OVERHEAD ILLUMINATION AND FLASHERS

Activities within the Work Zone often create conditions on or near the travel lane that are particularly hazardous at night when the road user's visibility is reduced. It is often necessary to supplement the reflectorized signs, barriers and channelizing devices with overhead lighting and/or barricade warning lights.

Special attention must be taken to ensure that portable overhead lighting does not “blind” the road users.

Barricade warning lights are either steady-burn or flashing type units. Steady-burn lights are used for delineation and should be mounted on a series of barricades or channelizing devices. Flashing lights are used to draw attention to warning signs in the Work Zone.

The types and intended use of barricade warning lights are:

- Type A

Type A Low Intensity Flashing Warning lights are most commonly mounted on barricades or advance warning signs, and are intended to warn motorists of an obstacle or other potential hazard.

- Type C

Type C Steady Burn lights are used to delineate the edge of the travelled way on detour curves, lane changes and transitions.

10. TYPICAL DRAWINGS

Typical drawings for temporary construction signing are included in this document and are classified into five categories:

1. Long Duration Activities (Drawing Nos. TCS-B-1.1A to 1.18A)
2. Short Duration Activities (Drawing Nos. TCS-B-2.1A to 2.8B)
3. Survey, Testing, and Other Activities (Short Duration) (Drawing Nos. TCS-B-3.1A to 3.4B)
4. Miscellaneous Activities (Drawing No. TCS-B-4.1 to 4.3)
5. Utilities Construction (Drawing Nos. TCS-B-5.1A to 5.3B)

These drawings indicate minimum requirements for typical situations. For unique activities, Work Zones or traffic flows, specialized drawings must be developed by the person performing the work.

SECTION II

**TYPICAL DRAWINGS FOR TEMPORARY
CONSTRUCTION SIGNING**

TRAFFIC ACCOMMODATION IN WORK ZONES

LIST OF DRAWINGS

LONG DURATION			
TCS-B Drawing No.	2 Lane Undivided Highway	4 Lane Divided Highway	Description
1.1A	X		One Lane Closure (One Lane Alternating Traffic)
1.1B		X	One Lane Closure
1.2A	X		No Lane Closure
1.2B		X	No Lane Closure
1.3A	X		Two Way Traffic (Reduced Roadway Width)
1.4A	X		Intersecting Roads
1.4B		X	Intersecting Roads
1.5A	X		Obstruction Within Work Area
1.6A	X		Truck Entrance (Haul Route)
1.6B		X	Truck Entrance (Haul Route)
1.7A	X		No Centre Line Pavement Marking
1.7B		X	No Centre Line Pavement Marking
1.8A	X		Detour
1.9A	X		Shoulder Drop-Off (Within Work Zone)
1.10A	X		Bridge Detour Two Way Traffic
1.10B		X	Bridge Detour
1.11A	X		Delineation For Embankments And Fixed Objects (Within The Work Zone)
1.11B		X	Delineation For Embankments And Fixed Objects (Within The Work Zone)
1.12B		X	Bridge Signing Two Lane Traffic (Reduced Bridge Width)
1.13B		X	Bridge Signing One Lane Closure
1.14A	X		Bridge Signing One Lane Closure (One Lane Alternating Traffic)
1.15B		X	Bridge Signing Bridge Deck Repair (Outside Lane Clover Leaf Interchanges)
1.16B		X	Bridge Signing Bridge Deck Repair (Inside Lane Clover Leaf Interchanges)
1.17A	X		Chip Seal Coating Operations
1.17B		X	Chip Seal Coating Operations
1.18A	X		Double Seal And Graded Aggregate Seal Coating Operations

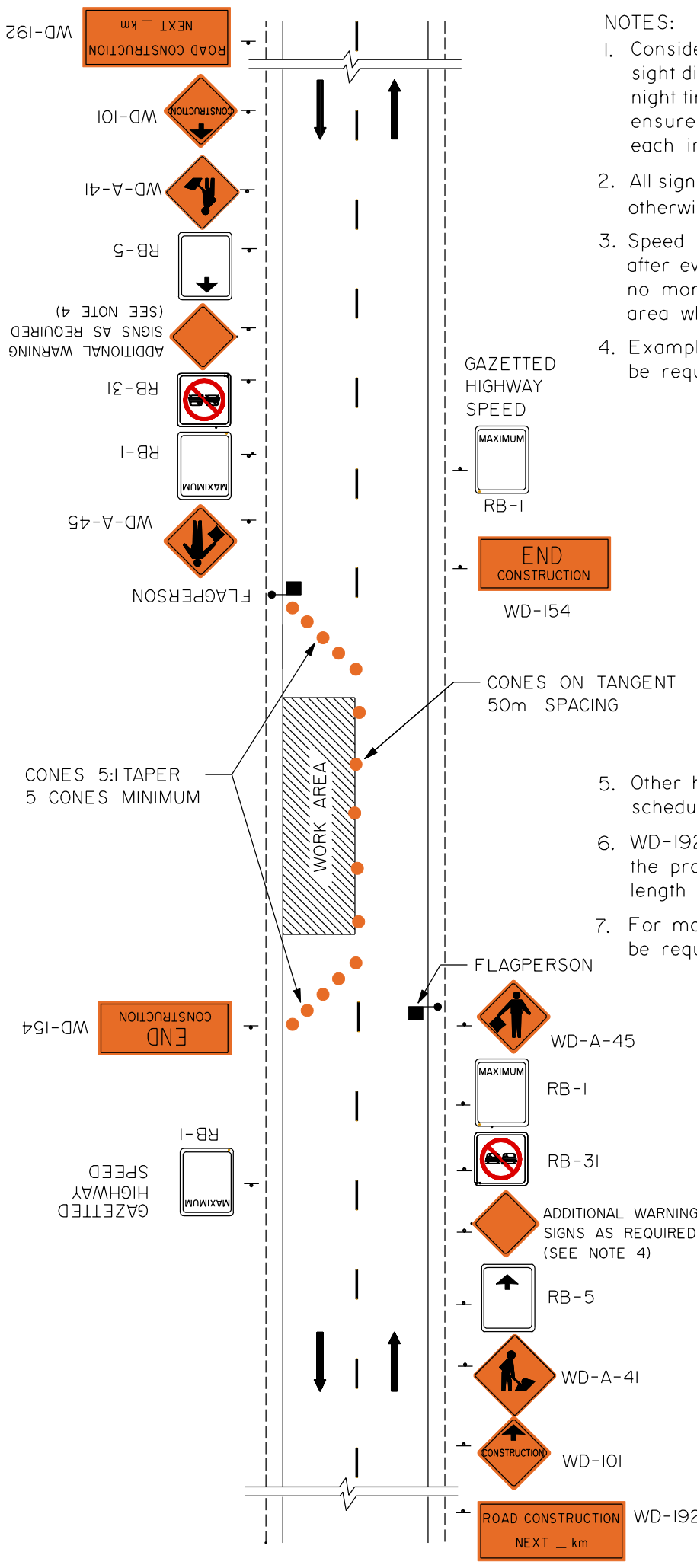

NOTES:

1. Consideration must be given to traffic volume, sight distances, sign spacing, duration of work, night time conditions and other factors to ensure traffic control devices are adequate in each instance.
2. All sign spacing shall be 100m-150m unless otherwise indicated.
3. Speed limit and warning signs shall be placed after every intersecting roadway and shall be no more than 5km apart throughout the work area where there is a restricted speed zone.
4. Examples of additional warning signs that may be required in conjunction with this plan are:
 - GROOVED PAVEMENT WD-A-III
 - LOOSE GRAVEL WD-150
 - SHARP SHOULDERS WD-A-22
 - BARRICADE WD-104
 - WD-A-49
 - FRESH OIL WD-157
5. Other hazard signs as shown in the schedule of signs may be used as required.
6. WD-192 shall be erected 2km in advance of the project. Distance tab to include project length plus setback from project limit.
7. For mobile operation, cones may not be required

No.	REVISIONS	BY	DATE
Approved:			
Executive Director, Technical Standards Branch			
Date:	MARCH, 2001		
TYPICAL SIGNING ONE LANE CLOSURE (ONE LANE ALTERNATING TRAFFIC) TWO LANE UNDIVIDED HIGHWAY			
Prepared By: G.E.C.	Checked By: P.H.	Scale: N.T.S.	Dwg No.: TCS-B-11A LONG DURATION

NOTES:

1. Consideration must be given to traffic volume, sight distances, sign spacing, duration of work, night time conditions and other factors to ensure traffic control devices are adequate in each instance.
2. All sign spacing shall be 100m-150m unless otherwise indicated.
3. Speed limit and warning signs shall be placed after every intersecting roadway and shall be no more than 5km apart throughout the work area where there is a restricted speed zone.
4. Examples of additional warning signs that may be required in conjunction with this plan are:

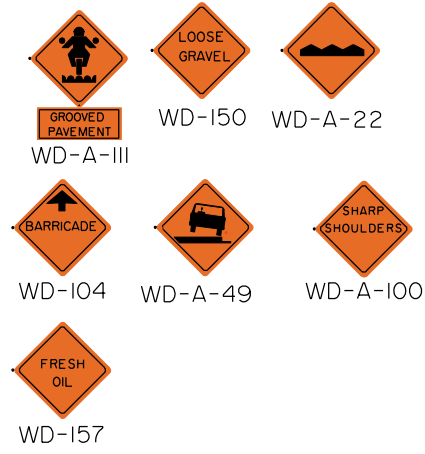

5. Other hazard signs as shown in the schedule of signs may be used as required.
6. The Sequential Arrow Board shall be located in the centre of the closed lane. An additional Sequential Arrow Board is required when traffic volume exceeds 8000 vehicles per day or when sight distance is restricted.
7. WD-192 shall be erected 2km in advance of the project. Distance tab to include project length plus setback from project limit.
8. For mobile operation, cones may not be required.

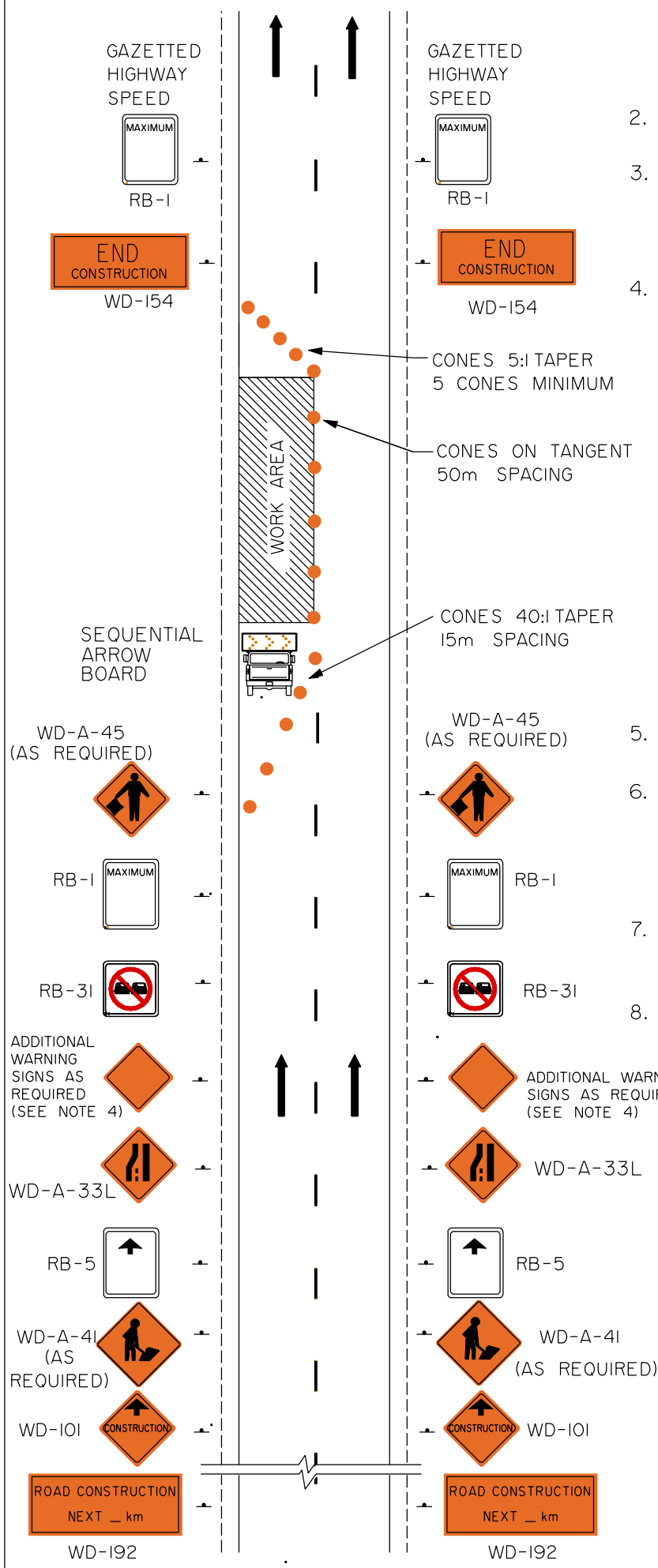

▲			
▲			
▲			
No.	REVISIONS	BY	DATE
Approved:			
Executive Director, Technical Standards Branch			
Date:	MARCH, 2001		
TYPICAL SIGNING ONE LANE CLOSURE FOUR LANE DIVIDED HIGHWAY			
Prepared By: G.E.C.	Checked By: P.H.	Scale: N.T.S.	Dwg No.: TCS-B-11B LONG DURATION

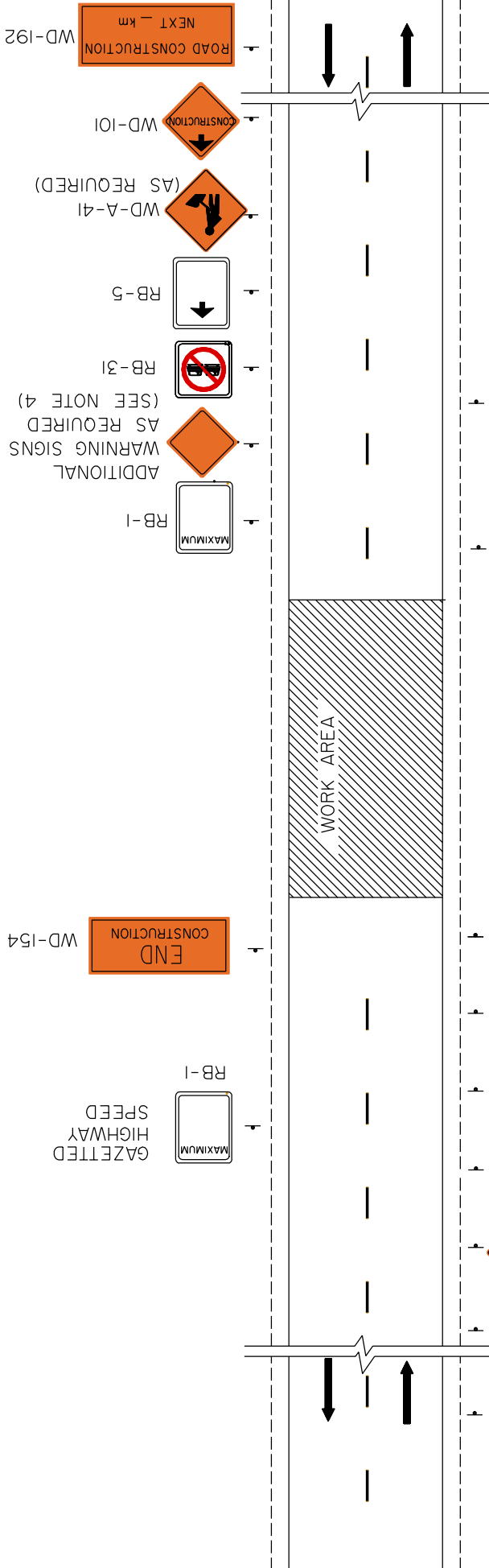

NOTES:

1. Consideration must be given to traffic volume, sight distances, sign spacing, duration of work, night time conditions and other factors to ensure traffic control devices are adequate in each instance.
2. All sign spacing shall be 100m-150m unless otherwise indicated.
3. Speed limit and warning signs shall be placed after every intersecting roadway and shall be no more than 5km apart throughout the work area where there is a restricted speed zone.
4. Examples of additional warning signs that may be required in conjunction with this plan are:
 - WD-A-III (GROOVED PAVEMENT)
 - WD-150 (LOOSE GRAVEL)
 - WD-A-22 (ROAD HUMP)
 - WD-104 (BARRICADE)
 - WD-A-45 (WORKER)
 - WD-A-100 (SHARP SHOULDERS)
 - WD-157 (FRESH OIL)
 - WD-A-49 (TRUCK)
5. Other hazard signs as shown in the schedule of signs may be used as required.
6. WD-192 shall be erected 2km in advance of the project. Distance tab to include project length plus setback from project limit.

GAZETTED HIGHWAY SPEED



RB-1



WD-154



RB-1



ADDITIONAL WARNING SIGNS AS REQUIRED (SEE NOTE 4)



RB-31



RB-5



WD-A-41 (AS REQUIRED)



WD-101



WD-192

No.	REVISIONS			BY	DATE	
Approved:						
Executive Director, Technical Standards Branch						
Date:	MARCH, 2001					
TYPICAL SIGNING NO LANE CLOSURE TWO LANE UNDIVIDED HIGHWAY						
Prepared By: G.E.C.	Checked By: P.H.	Scale: N.T.S.	Dwg No.:	TCS-B-1.2A		
				LONG DURATION		

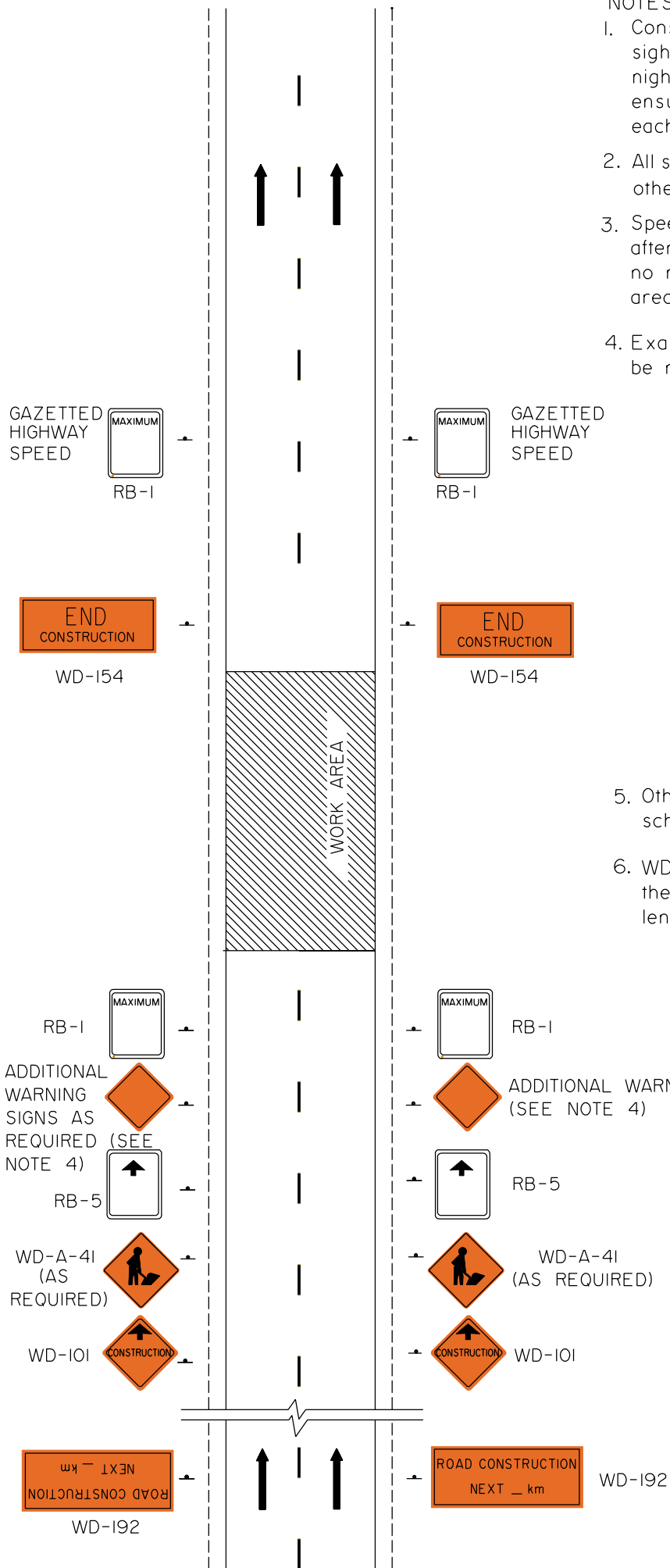

NOTES:

1. Consideration must be given to traffic volume, sight distances, sign spacing, duration of work, night time conditions and other factors to ensure traffic control devices are adequate in each instance.
2. All sign spacing shall be 100m-150m unless otherwise indicated.
3. Speed limit and warning signs shall be placed after every intersecting roadway and shall be no more than 5km apart throughout the work area where there is a restricted speed zone.
4. Examples of additional warning signs that may be required in conjunction with this plan are:

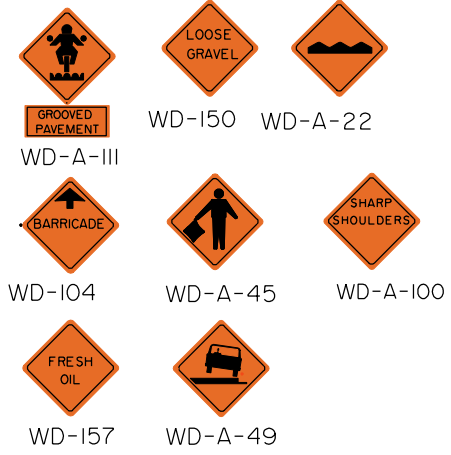

5. Other hazard signs as shown in the schedule of signs may be used as required.
6. WD-192 shall be erected 2km in advance of the project. Distance tab to include project length plus setback from project limit.

No.	REVISIONS	BY	DATE
Approved: _____ Executive Director, Technical Standards Branch			
Date:	MARCH, 2001		
TYPICAL SIGNING NO LANE CLOSURE FOUR LANE DIVIDED HIGHWAY			
Prepared By: G.E.C.	Checked By: P.H.	Scale: N.T.S.	Dwg No.: TCS-B-1.2B LONG DURATION

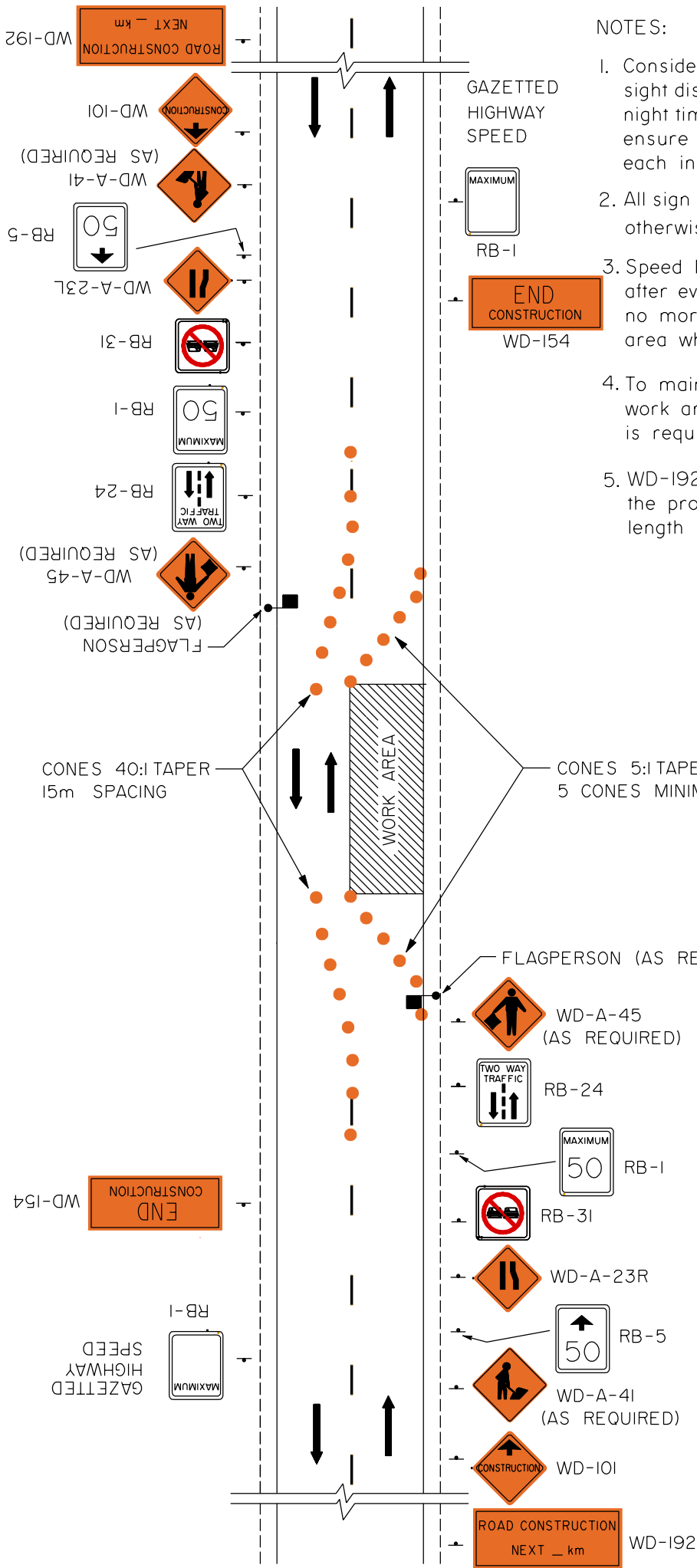

NOTES:

1. Consideration must be given to traffic volume, sight distances, sign spacing, duration of work, night time conditions and other factors to ensure traffic control devices are adequate in each instance.
2. All sign spacing shall be 100m-150m unless otherwise indicated.
3. Speed limit and warning signs shall be placed after every intersecting roadway and shall be no more than 5km apart throughout the work area where there is a restricted speed zone.
4. To maintain two lane traffic around the work area, a minimum width of 3.5m is required for each lane.
5. WD-192 shall be erected 2km in advance of the project. Distance tab to include project length plus setback from project limit.

CONES 40:1 TAPER
15m SPACING

CONES 5:1 TAPER
5 CONES MINIMUM

No.	REVISIONS	BY	DATE

Approved: _____
Executive Director,
Technical Standards Branch

Date: MARCH, 2001



TYPICAL SIGNING
TWO WAY TRAFFIC
(REDUCED ROADWAY WIDTH)
TWO LANE UNDIVIDED HIGHWAY

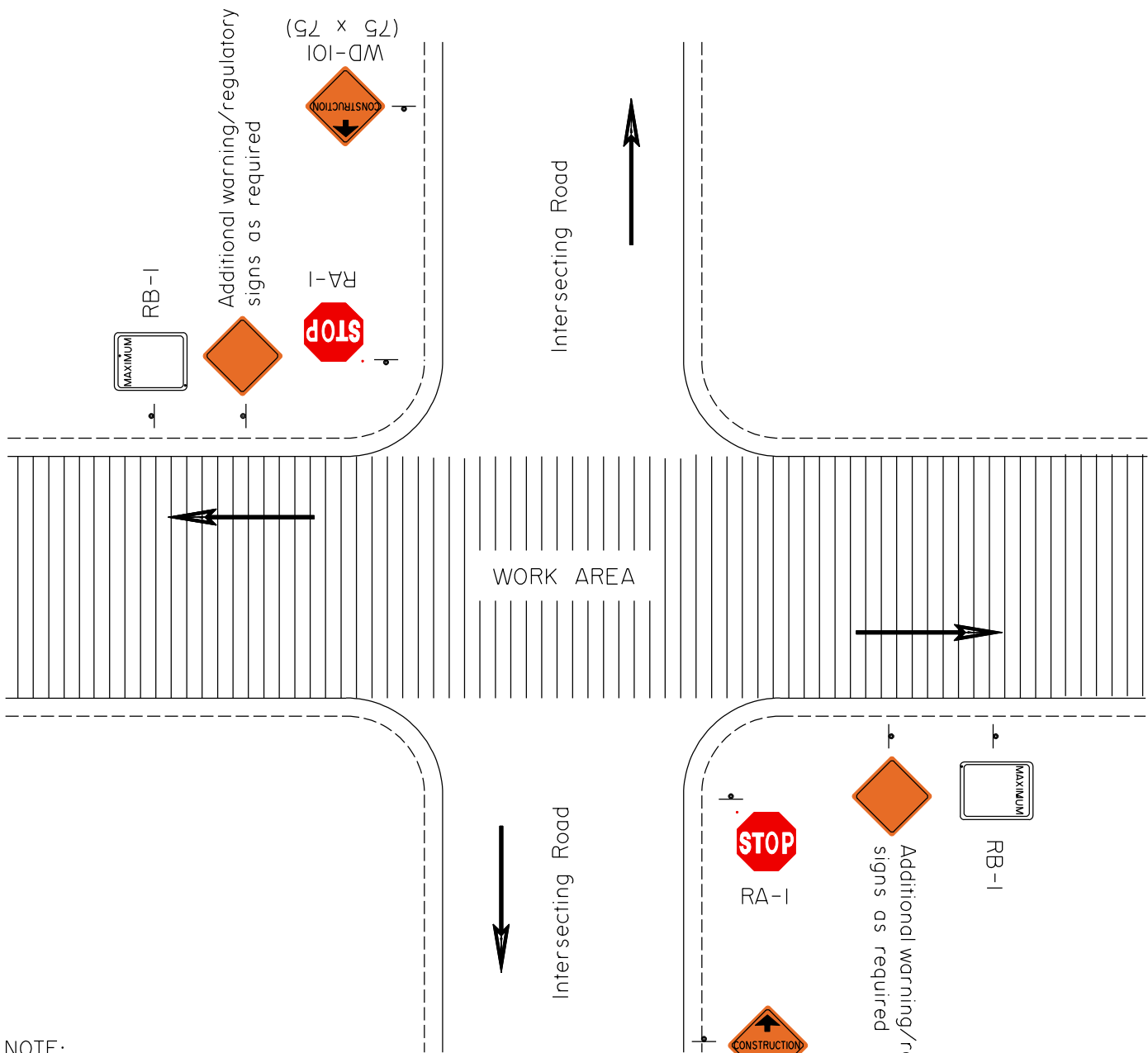

NOTE:

1. Consideration must be given to traffic volume, sight distances, sign spacing, duration of work, night time conditions and other factors to ensure traffic control devices are adequate in each instance.
2. All sign spacing shall be 100m-150m unless otherwise indicated.

No.	REVISIONS	BY	DATE
Approved:			
Executive Director, Technical Standards Branch			
Date:	MARCH, 2001		
TYPICAL SIGNING INTERSECTING ROADS TWO LANE UNDIVIDED HIGHWAY			
Prepared By: G.E.C.	Checked By: P.H.	Scale: N.T.S.	Dwg No.: TCS-B-1.4A LONG DURATION

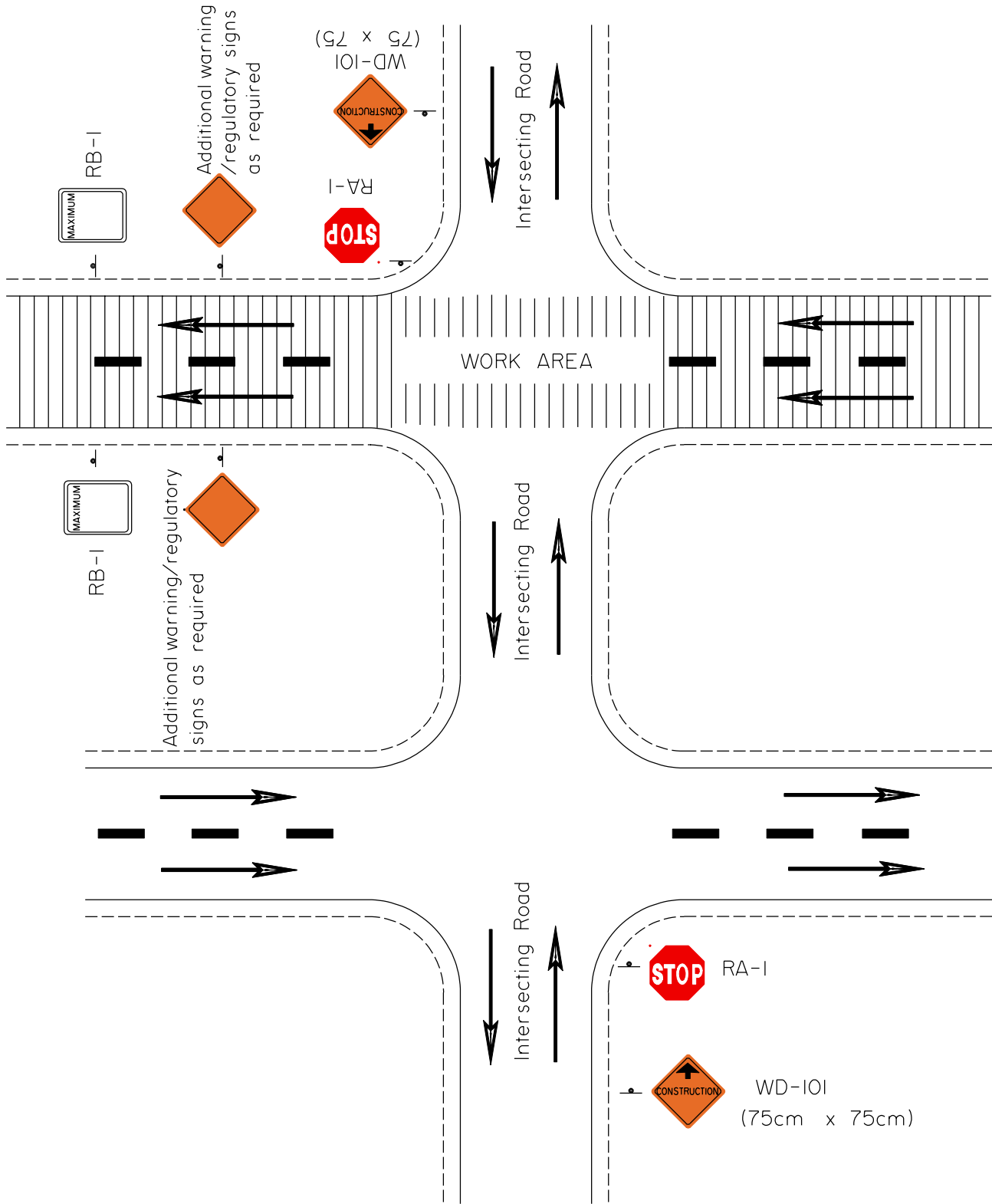

NOTE:

1. Consideration must be given to traffic volume, sight distances, sign spacing, duration of work, night time conditions and other factors to ensure traffic control devices are adequate in each instance.
2. All sign spacing shall be 100m-150m unless otherwise indicated.

No.	REVISIONS	BY	DATE
Approved:			
Executive Director, Technical Standards Branch			
Date:	MARCH, 2001		
TYPICAL SIGNING INTERSECTING ROADS FOUR LANE DIVIDED HIGHWAY			
Prepared By: G.E.C.	Checked By: P.H.	Scale: N.T.S.	Dwg No.: TCS-B-1.4B LONG DURATION

NOTES:

1. Consideration must be given to traffic volume, sight distances, sign spacing, duration of work, night time conditions and other factors to ensure traffic control devices are adequate in each instance.
2. All sign spacing shall be 100m-150m unless otherwise indicated.
3. Speed limit and warning signs shall be placed after every intersecting roadway and shall be no more than 5km apart throughout the work area where there is a restricted speed zone.
4. During darkness two type "A" flashing lights shall be placed on each barricade.
5. A minimum lane width of 3.5m must be maintained.

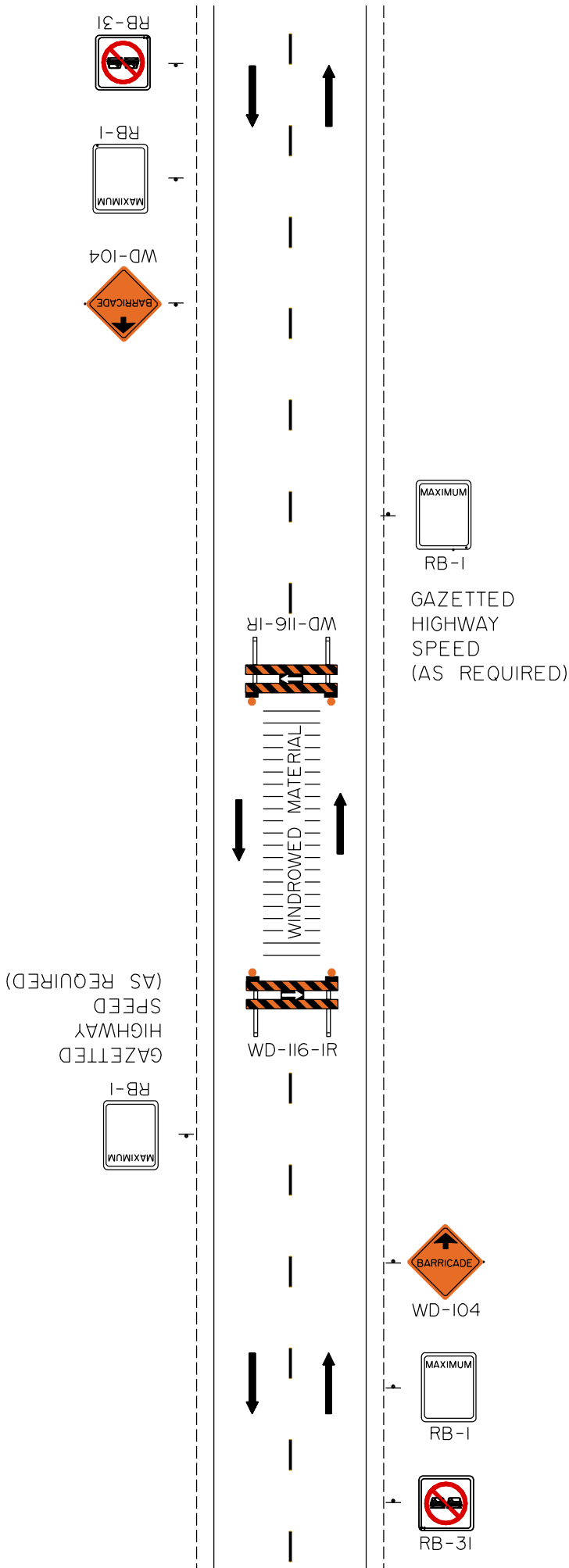

No.	REVISIONS	BY	DATE
Approved:			
Executive Director, Technical Standards Branch			
Date:	MARCH, 2001		
TYPICAL SIGNING OBSTRUCTION WITHIN WORK AREA TWO LANE UNDIVIDED HIGHWAY			
Prepared By: G.E.C.	Checked By: P.H.	Scale: N.T.S.	Dwg No.: TCS-B-1.5A LONG DURATION

NOTES:

- I. Consideration must be given to traffic volume, sight distances, sign spacing, duration of work, night time conditions and other factors to ensure traffic control devices are adequate in each instance.

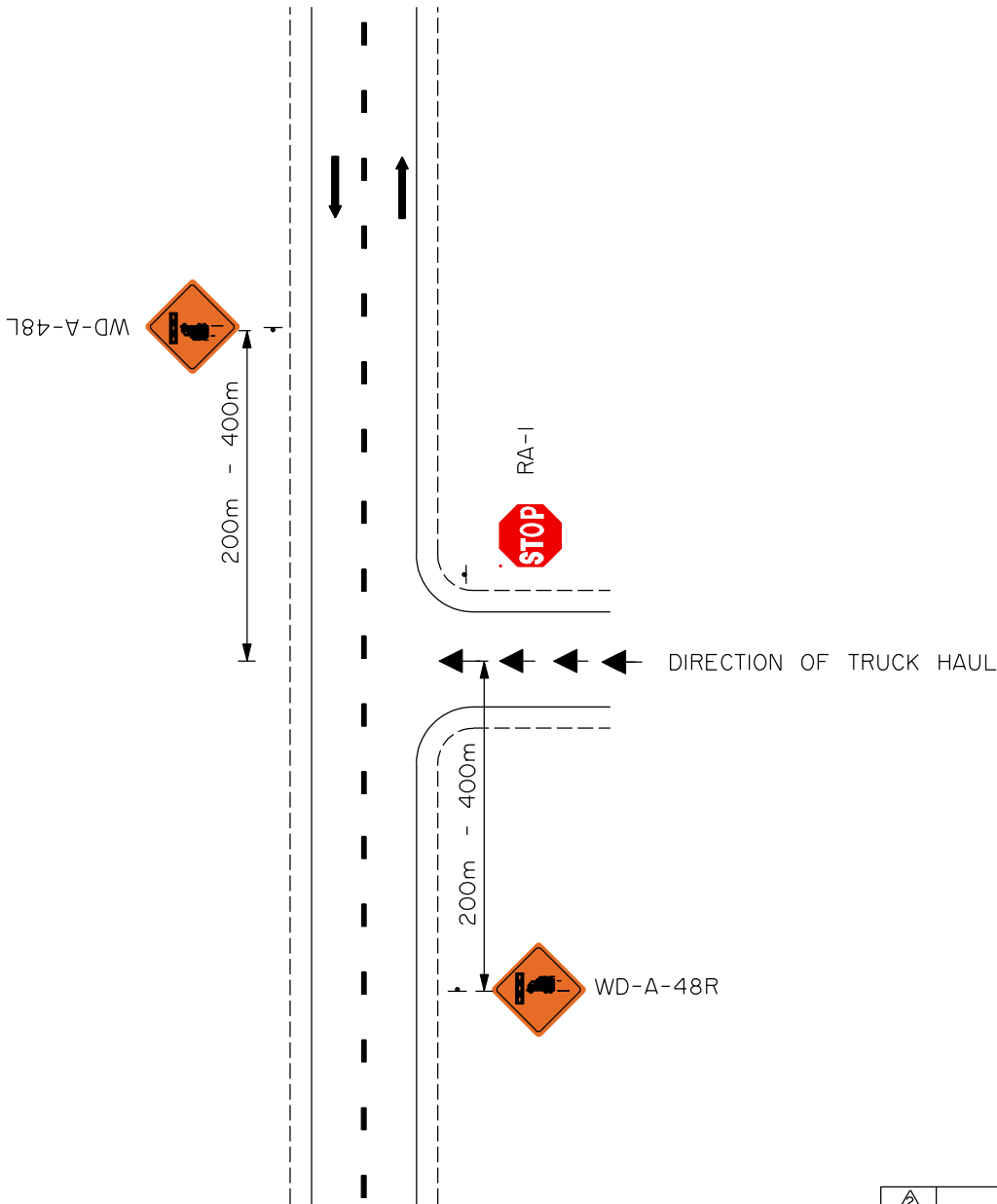

No.	REVISIONS		BY DATE
Approved:			
----- Executive Director, Technical Standards Branch			
Date:	MARCH, 2001		
TYPICAL SIGNING TRUCK ENTRANCE (HAUL ROUTE) TWO LANE UNDIVIDED HIGHWAY			
Prepared By: G.E.C.	Checked By: P.H.	Scale: N.T.S.	Dwg No.: TCS-B-16A LONG DURATION

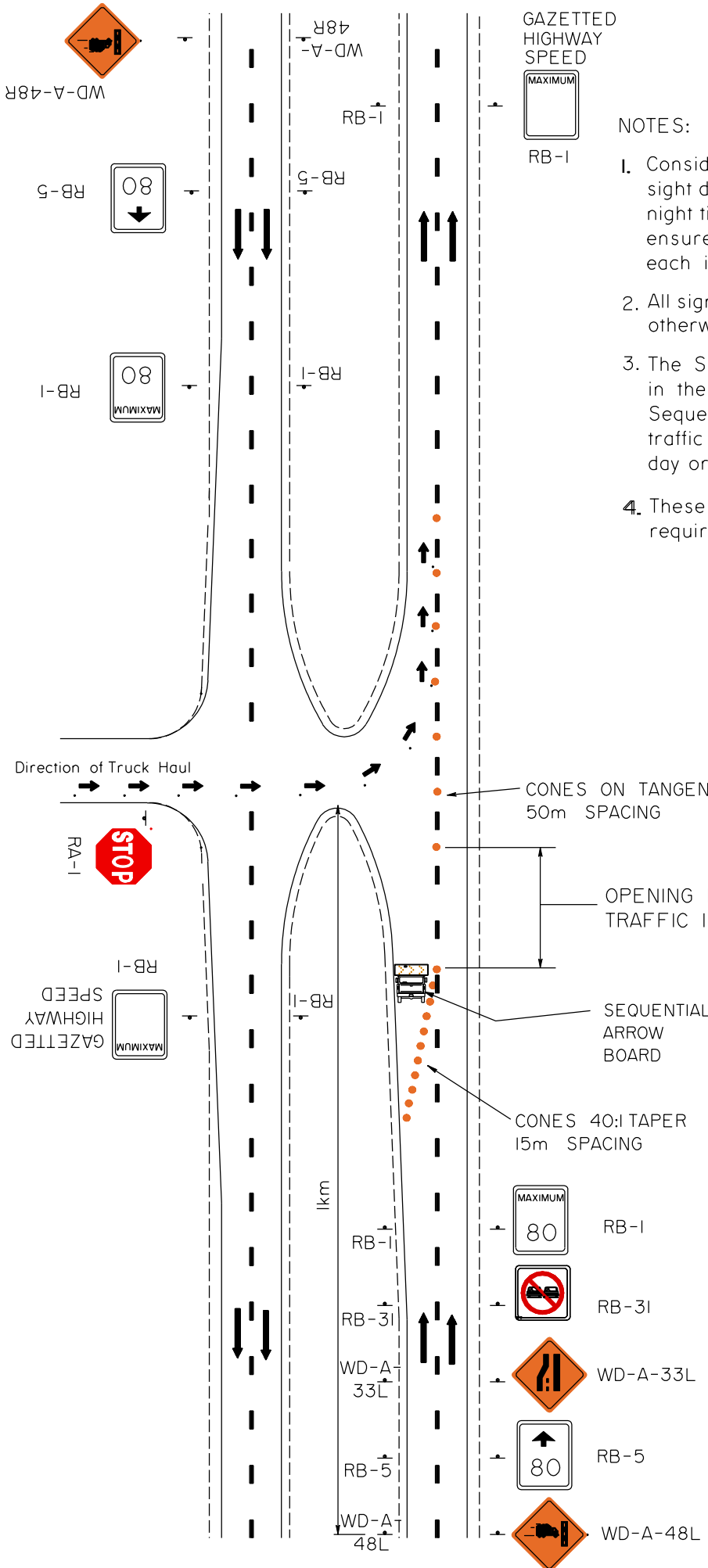

GAZETTED
HIGHWAY
SPEED
MAXIMUM
RB-1

NOTES:

1. Consideration must be given to traffic volume, sight distances, sign spacing, duration of work, night time conditions and other factors to ensure traffic control devices are adequate in each instance.
2. All sign spacing shall be 100m-150m unless otherwise indicated.
3. The Sequential Arrow Board shall be located in the centre of the closed lane. An additional Sequential Arrow Board is required when traffic volume exceeds 8000 vehicles per day or when sight distance is restricted.
4. These signing details may not necessarily be required at all temporary truck entrances.

CONES ON TANGENT
50m SPACING

OPENING FOR LEFT TURNING
TRAFFIC IS REQUIRED

SEQUENTIAL
ARROW
BOARD

CONES 40:1 TAPER
15m SPACING

MAXIMUM
80 RB-1

RB-31

WD-A-33L

80 RB-5

WD-A-48L

△			
△			
No.	REVISIONS	BY	DATE
Approved:			
Executive Director, Technical Standards Branch			
Date:	MARCH, 2001		
TYPICAL SIGNING TRUCK ENTRANCE (HAUL ROUTE) FOUR LANE DIVIDED HIGHWAY			
Prepared By: G.E.C.	Checked By: P.H.	Scale: N.T.S.	Dwg No.: TSC-B-1.6B LONG DURATION

NOTES:

1. Consideration must be given to traffic volume, sight distances, sign spacing, duration of work, night time conditions and other factors to ensure traffic control devices are adequate in each instance.
2. All sign spacing shall be 100m-150m unless otherwise indicated.
3. Speed limit/warning signs shall be placed after every intersecting roadway and shall be no more than 5km apart throughout the work area where there is a restricted speed zone.
4. Temporary pavement marking requirement shall be as per specification.
5. WD-192 shall be erected 2km in advance of the project. Distance tab to include project length plus setback from project limit.

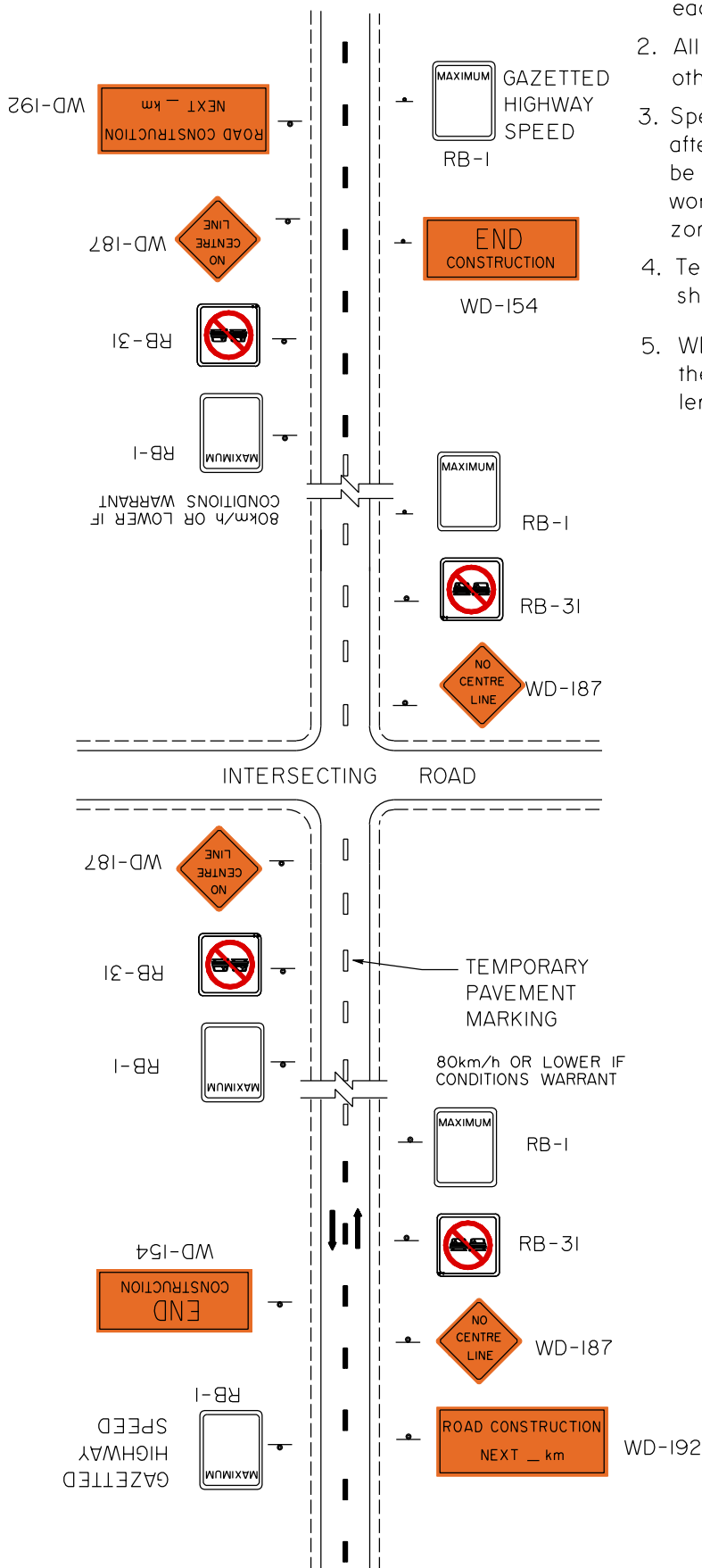

No.		BY	DATE
Approved:			
Executive Director, Technical Standards Branch			
Date:	MARCH, 2001		
TYPICAL SIGNING NO CENTRE LINE PAVEMENT MARKING TWO LANE UNDIVIDED HIGHWAY			
Prepared By: G.E.C.	Checked By: P.H.	Scale: N.T.S.	Dwg No.: TCS-B-17A LONG DURATION

NOTES:

1. Consideration must be given to traffic volume, sight distances, sign spacing, duration of work, night time conditions and other factors to ensure traffic control devices are adequate in each instance.
2. All sign spacing shall be 100m-150m unless otherwise indicated.
3. Speed limit/warning signs shall be placed after every intersecting roadway and shall be no more than 5km apart throughout the work area where there is a restricted speed zone.
4. Temporary pavement marking requirement shall be as per specification.
5. WD-192 shall be erected 2km in advance of the project. Distance tab to include project length plus setback from project limit.

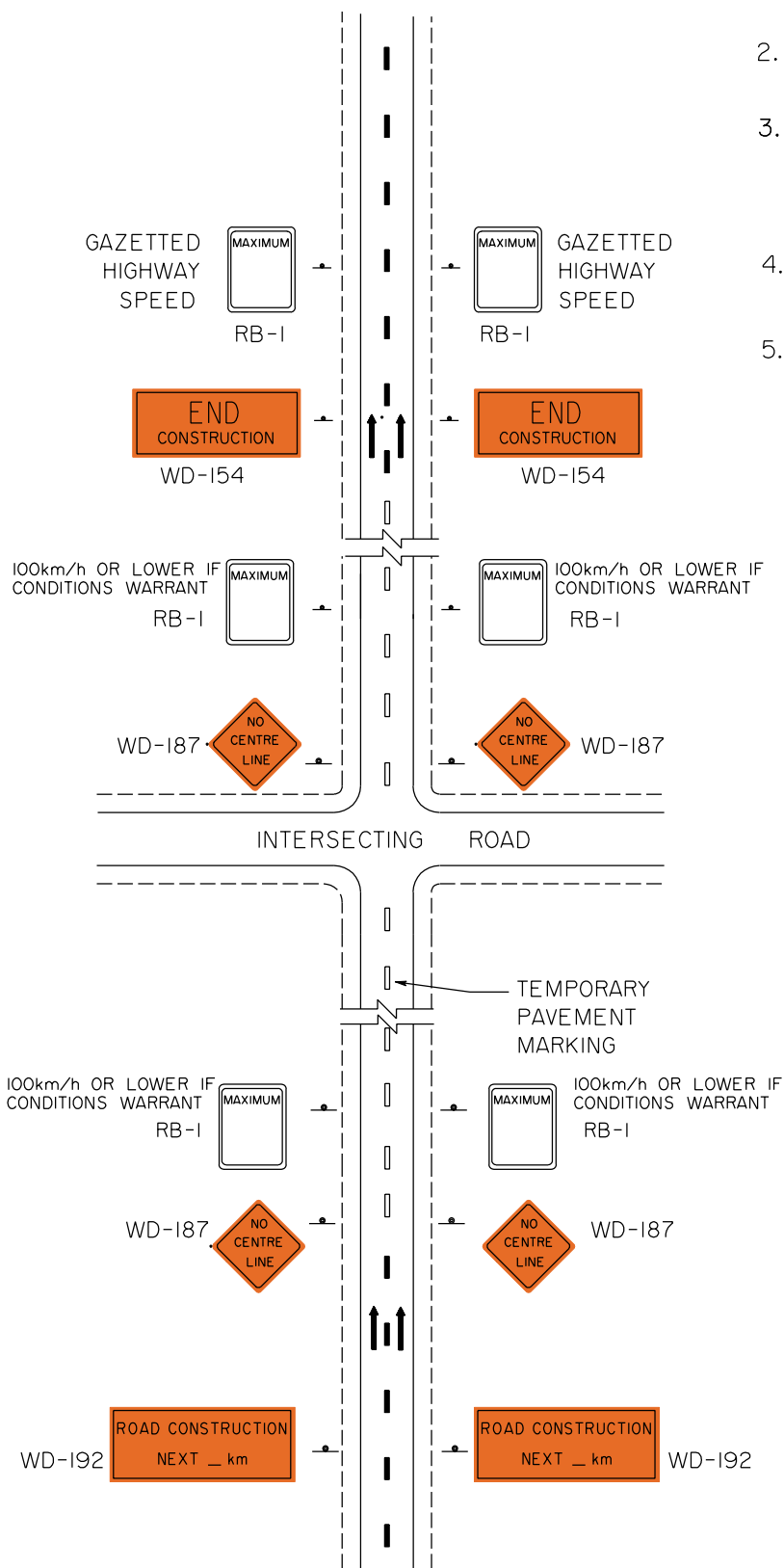

No.	REVISIONS	BY	DATE
Approved:			
_____ Executive Director, Technical Standards Branch			
Date:	MARCH, 2001		
TYPICAL SIGNING NO CENTRE LINE PAVEMENT MARKING FOUR LANE DIVIDED HIGHWAY			
Prepared By: G.E.C.	Checked By: P.H.	Scale: N.T.S.	Dwg No.: TCS-B-1.7B LONG DURATION

NOTES:

1. Consideration must be given to traffic volume, sight distances, sign spacing, duration of work, night time conditions and other factors to ensure traffic control devices are adequate in each instance.
2. All sign spacing shall be 100m-150m unless otherwise indicated.
3. For all detours, customised plans will be required.
4. Intersection control must be determined for each intersection on the detour route and must conform to appropriate legislation.
5. Detour speed limit must be appropriate for each detour route.
6. During darkness, two type "A" flashing lights shall be placed on each barricade.

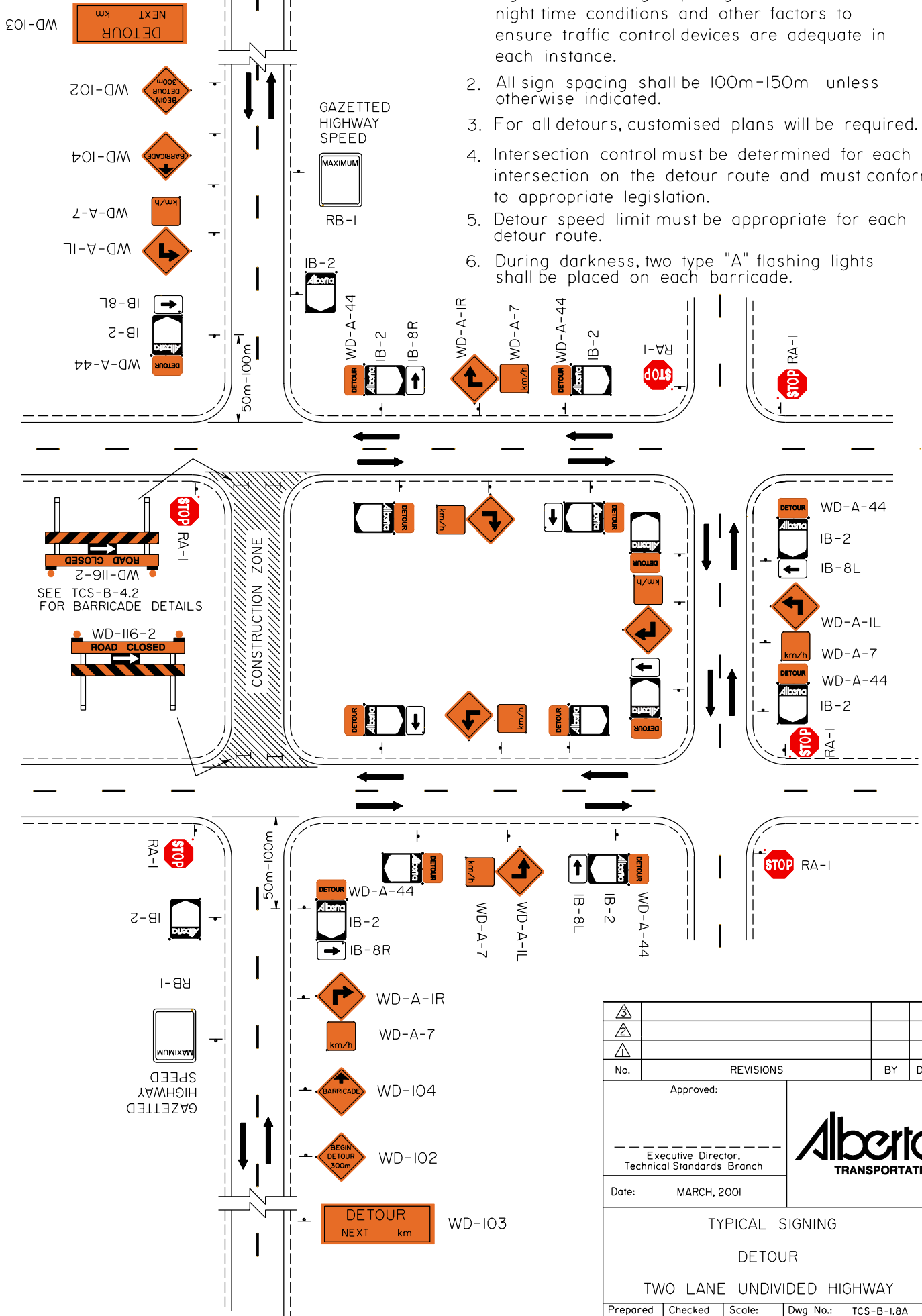

No.	REVISIONS	BY	DATE

Approved:			
Executive Director, Technical Standards Branch			
Date:	MARCH, 2001		
TYPICAL SIGNING DETOUR TWO LANE UNDIVIDED HIGHWAY			
Prepared By: G.E.C.	Checked By: P.H.	Scale: N.T.S.	Dwg No.: TCS-B-1,8A LONG DURATION

NOTES:

1. Consideration must be given to traffic volume, sight distances, sign spacing, duration of work, night time conditions and other factors to ensure traffic control devices are adequate in each instance.
2. All sign spacing shall be 100m-150m unless otherwise indicated.
3. Delineators with large bases at intervals of 20m. If the drop-off has a slope flatter than 3:1, delineator posts are not required.
4. During darkness, one type 'A' flashing light shall be placed on the barricade.

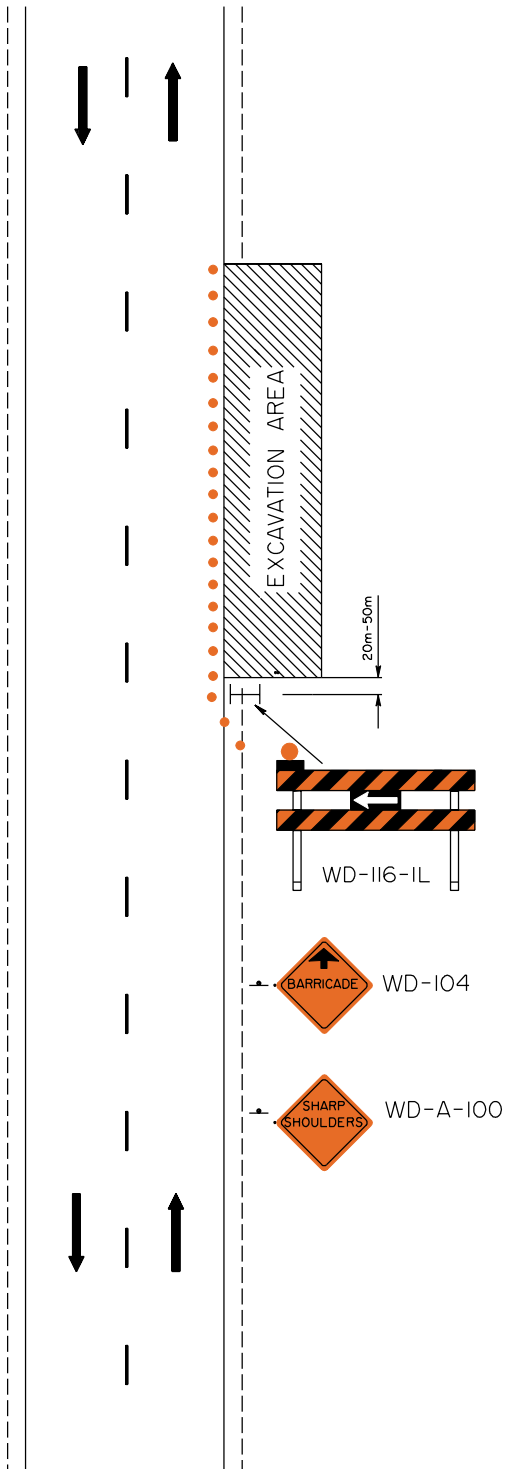

No.	REVISIONS	BY	DATE
Approved:			
Executive Director, Technical Standards Branch			
Date:	MARCH, 2001		
TYPICAL SIGNING SHOULDER DROP-OFF (WITHIN WORK ZONE) TWO LANE UNDIVIDED HIGHWAY			
Prepared By: G.E.C.	Checked By: P.H.	Scale: N.T.S.	Dwg No.: TCS-B-1.9A LONG DURATION

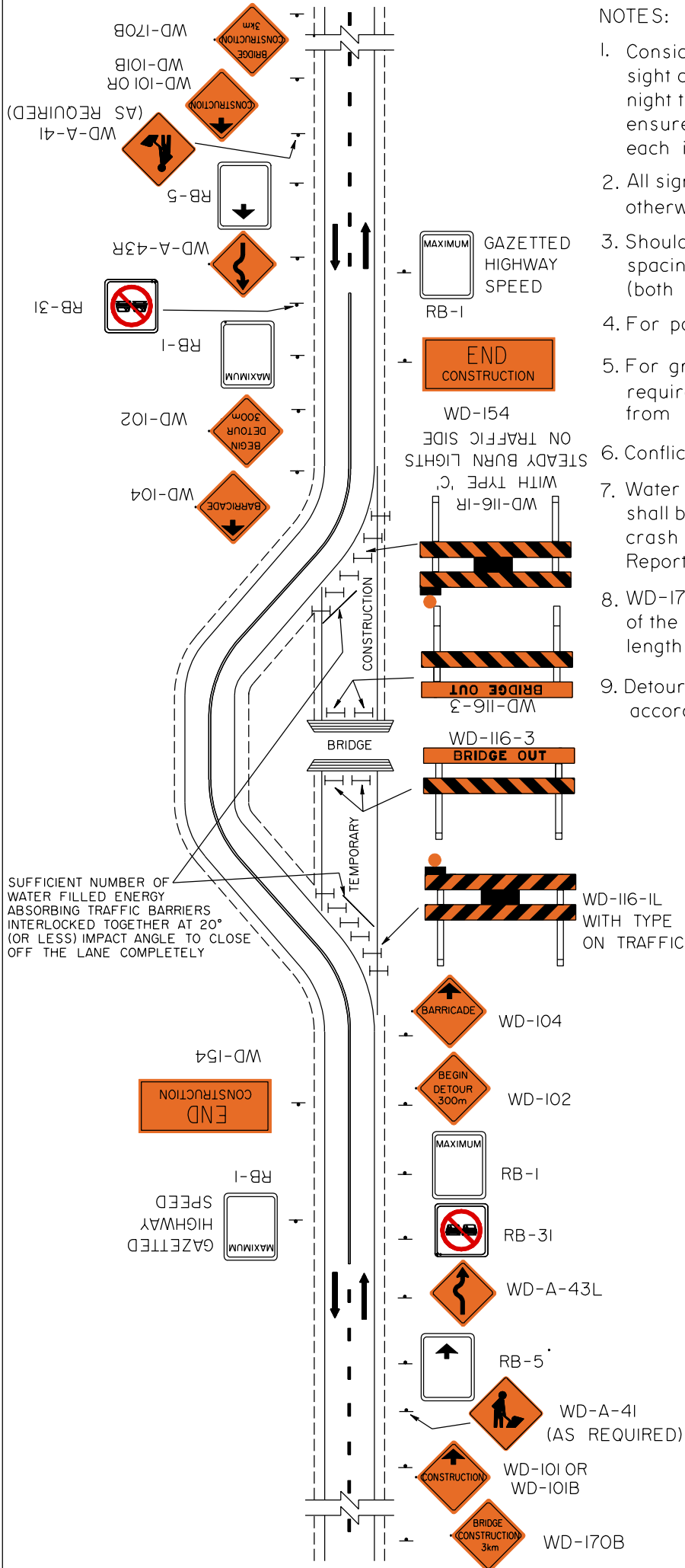

- NOTES:
1. Consideration must be given to traffic volume, sight distances, sign spacing, duration of work, night time conditions and other factors to ensure traffic control devices are adequate in each instance.
 2. All sign spacing shall be 100m-150m unless otherwise indicated.
 3. Shoulder delineation is required on 15m spacing along the length of the detour (both sides).
 4. For paved detours, line painting is required.
 5. For gravel detours, Davidson markers are required to transition painted line markings from the paved surface.
 6. Conflicting lane markings shall be removed.
 7. Water filled energy absorbing traffic barriers shall be of an approved type that has been crash tested (to meet Level 2 under NCHRP Report 350).
 8. WD-170B shall be erected 3km in advance of the project. Distance tab to include project length plus setback from project limit.
 9. Detour shall be designed and illuminated according to Highway Geometric Design Guide.

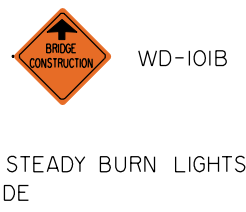

△			
△			
No.	REVISIONS	BY	DATE
Approved:			
Executive Director, Technical Standards Branch			
Date:	MARCH, 2001		
TYPICAL BRIDGE DETOUR SIGNING TWO WAY TRAFFIC TWO LANE UNDIVIDED HIGHWAY			
Prepared By: G.E.C.	Checked By: P.H.	Scale: N.T.S.	Dwg No.: TCS-B-110A LONG DURATION

NOTES:

1. Consideration must be given to traffic volume, sight distances, sign spacing, duration of work, night time conditions and other factors to ensure traffic control devices are adequate in each instance.
2. All sign spacing shall be 100m-150m unless otherwise indicated.
3. During darkness, one type 'A' flashing light shall be placed on each barricade.

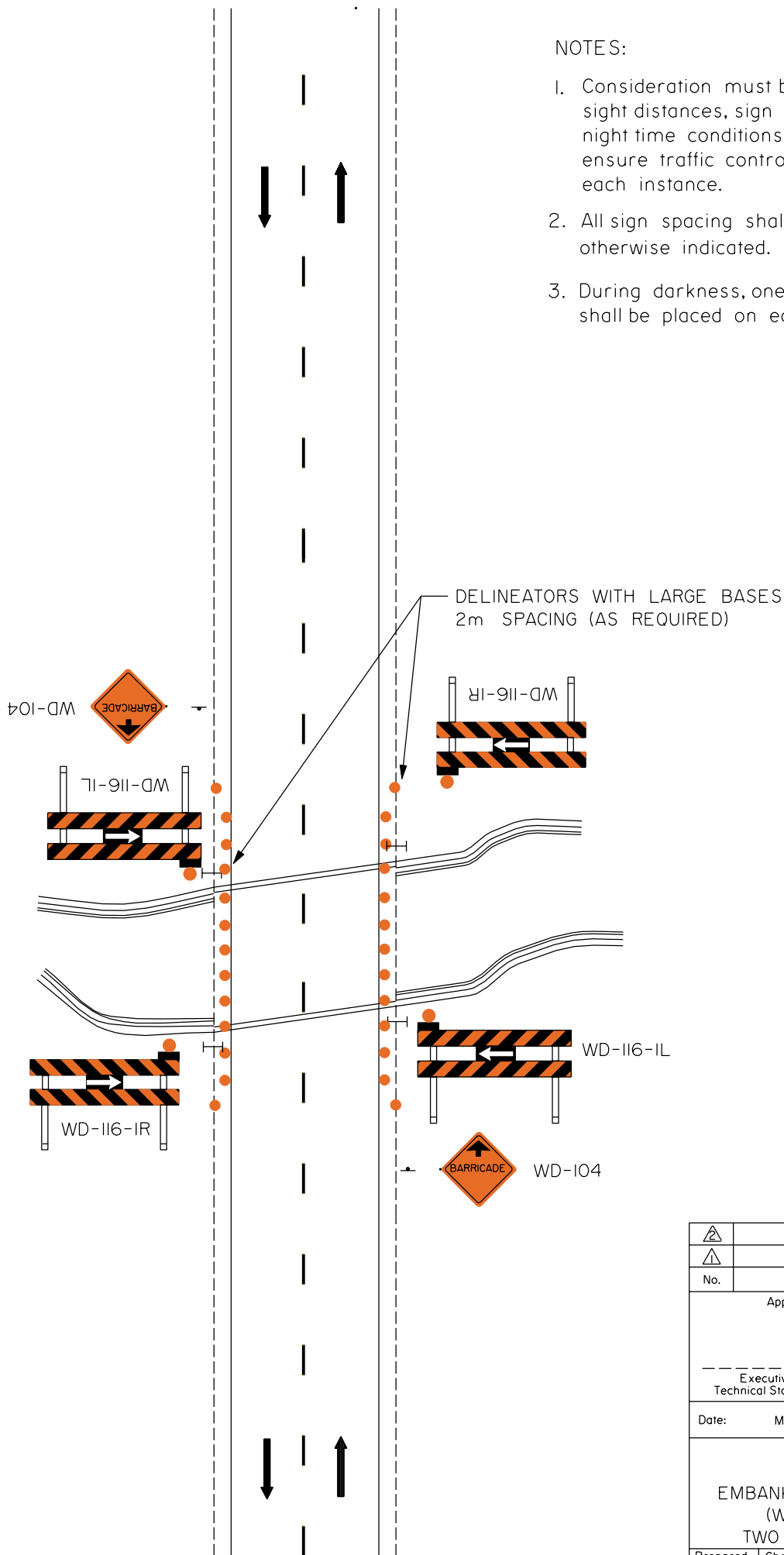

No.	REVISIONS		BY DATE
Approved:			
----- Executive Director, Technical Standards Branch			
Date:	MARCH, 2001		
TYPICAL SIGNING AND DELINEATION FOR EMBANKMENTS AND FIXED OBJECTS (WITHIN THE WORK ZONE) TWO LANE UNDIVIDED HIGHWAY			
Prepared By: G.E.C.	Checked By: P.H.	Scale: N.T.S.	Dwg No.: TCS-B-111A LONG DURATION

NOTES:

1. Consideration must be given to traffic volume, sight distances, sign spacing, duration of work, night time conditions and other factors to ensure traffic control devices are adequate in each instance.
2. All sign spacing shall be 100m-150m unless otherwise indicated.
3. During darkness, one type 'A' flashing light shall be placed on each barricade.

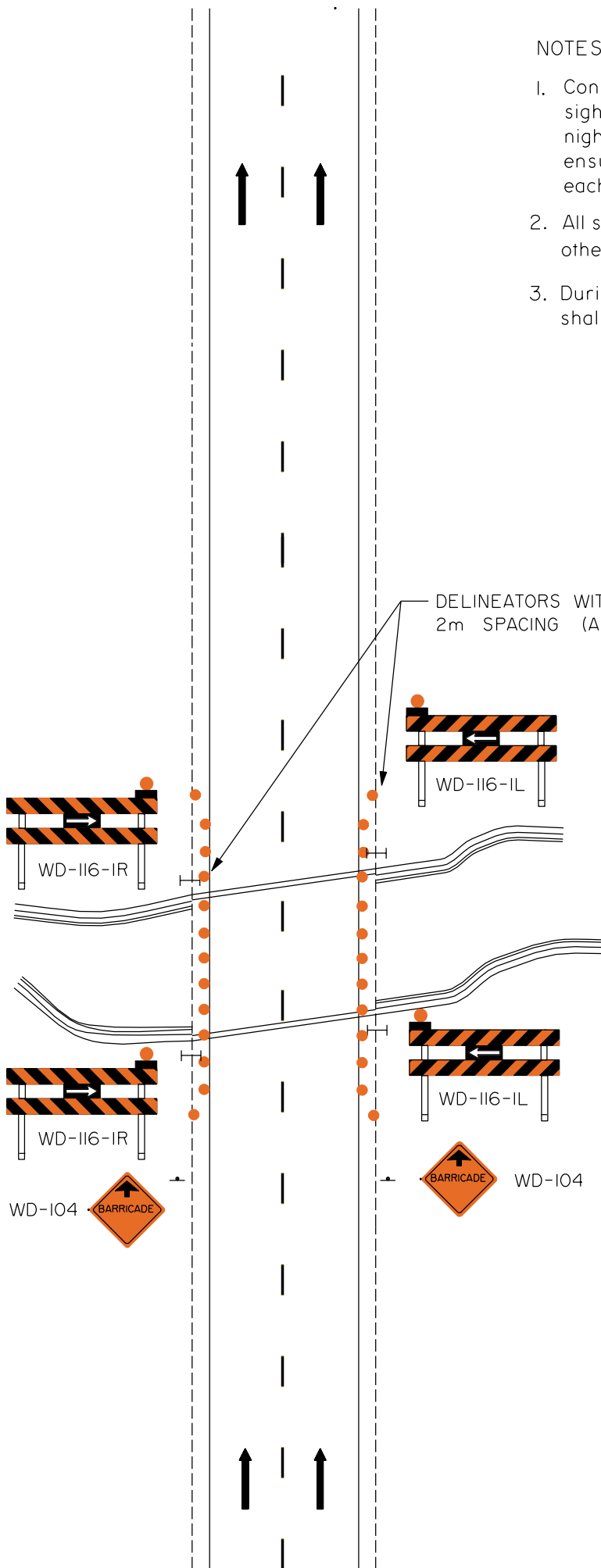

No.	REVISIONS	BY	DATE
Approved:			
Executive Director, Technical Standards Branch			
Date:	MARCH, 2001		
TYPICAL SIGNING AND DELINEATION FOR EMBANKMENTS AND FIXED OBJECTS (WITHIN THE WORK ZONE) FOUR LANE DIVIDED HIGHWAY			
Prepared By: G.E.C.	Checked By: P.H.	Scale: N.T.S.	Dwg No.: TCS-B-111B LONG DURATION

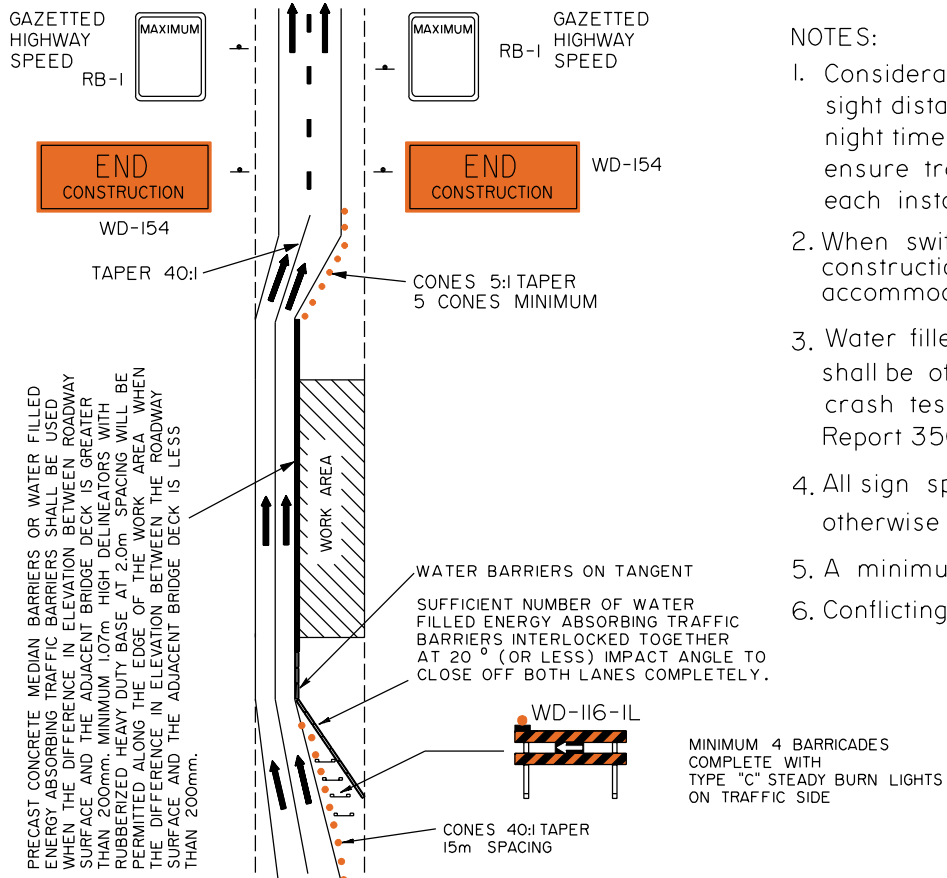

PRECAST CONCRETE MEDIAN BARRIERS OR WATER FILLED ENERGY ABSORBING TRAFFIC BARRIERS SHALL BE USED WHEN THE DIFFERENCE IN ELEVATION BETWEEN ROADWAY SURFACE AND THE ADJACENT BRIDGE DECK IS GREATER THAN 200mm. MINIMUM 107mm HIGH DELINEATORS WITH RUBBERIZED HEAVY DUTY BASE AT 2.0m SPACING WILL BE PERMITTED ALONG THE EDGE OF THE WORK AREA WHEN THE DIFFERENCE IN ELEVATION BETWEEN THE ROADWAY SURFACE AND THE ADJACENT BRIDGE DECK IS LESS THAN 200mm.

NOTES:

1. Consideration must be given to traffic volume, sight distances, sign spacing, duration of work, night time conditions and other factors to ensure traffic control devices are adequate in each instance.
2. When switching traffic during staged construction, a specialized traffic accommodation plan is required.
3. Water filled energy absorbing traffic barriers shall be of an approved type that has been crash tested (to meet Level 2 under NCHRP Report 350).
4. All sign spacing shall be 100m - 150m unless otherwise indicated.
5. A minimum lane width of 3.5m is required.
6. Conflicting lane markings shall be removed.

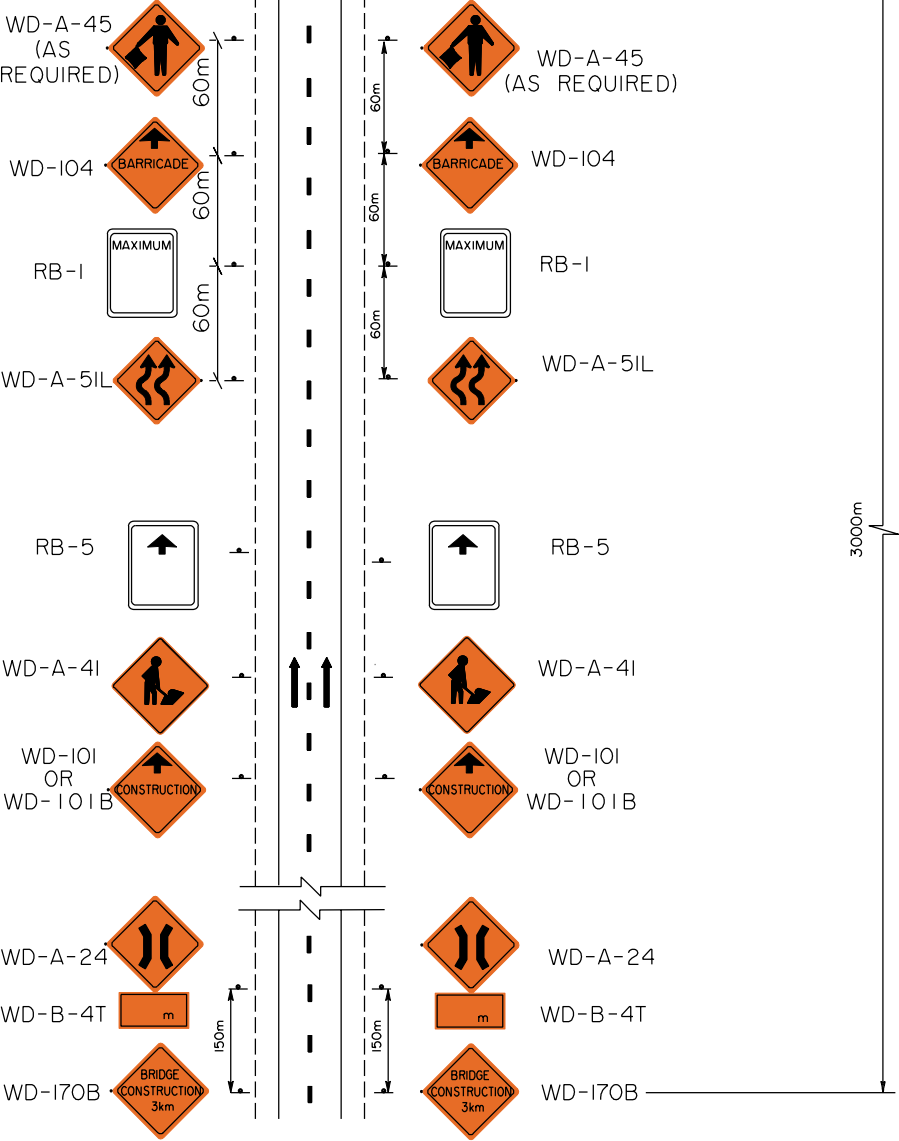

No.	REVISIONS		BY	DATE
Approved:				
Executive Director, Technical Standards Branch				
Date:	MARCH, 2001			
TYPICAL BRIDGE SIGNING TWO LANES TRAFFIC (REDUCED BRIDGE WIDTH) FOUR LANE DIVIDED HIGHWAY				
Prepared By: G.E.C.	Checked By: P.H.	Scale: N.T.S.	Dwg No.:	TCS-B-112B LONG DURATION

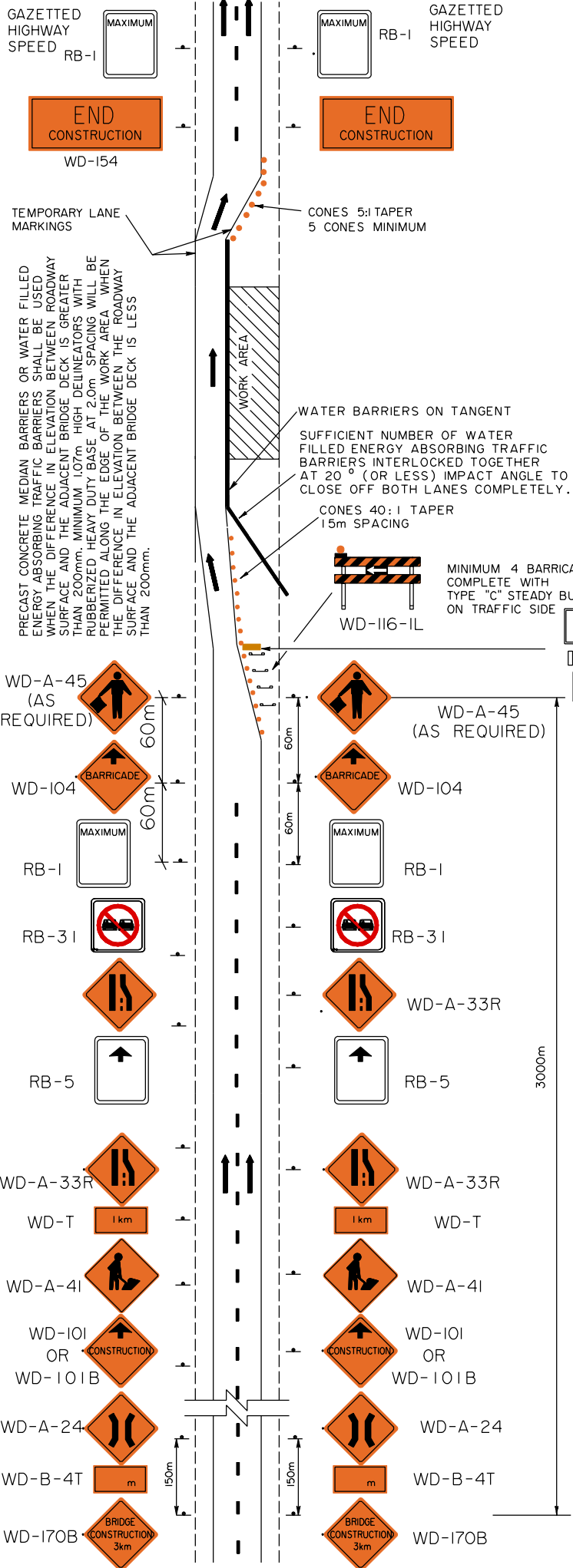

PRECAST CONCRETE MEDIAN BARRIERS OR WATER FILLED ENERGY ABSORBING TRAFFIC BARRIERS SHALL BE USED WHEN THE DIFFERENCE IN ELEVATION BETWEEN ROADWAY SURFACE AND THE ADJACENT BRIDGE DECK IS GREATER THAN 200mm. MINIMUM 1.07m HIGH DELINEATORS WITH RUBBERIZED HEAVY DUTY BASE AT 2.0m SPACING WILL BE PERMITTED ALONG THE EDGE OF THE WORK AREA WHEN THE DIFFERENCE IN ELEVATION BETWEEN THE ROADWAY SURFACE AND THE ADJACENT BRIDGE DECK IS LESS THAN 200mm.

WATER BARRIERS ON TANGENT
SUFFICIENT NUMBER OF WATER FILLED ENERGY ABSORBING TRAFFIC BARRIERS INTERLOCKED TOGETHER AT 20° (OR LESS) IMPACT ANGLE TO CLOSE OFF BOTH LANES COMPLETELY.

CONES 40:1 TAPER
15m SPACING

MINIMUM 4 BARRICADES COMPLETE WITH TYPE "C" STEADY BURN LIGHTS ON TRAFFIC SIDE

NOTES:

1. Consideration must be given to traffic volume, sight distances, sign spacing, duration of work, night time conditions and other factors to ensure traffic control devices are adequate in each instance.
2. When switching traffic during staged construction, a specialized traffic accommodation plan is required.
3. Water filled energy absorbing traffic barriers shall be of an approved type that has been crash tested (to meet Level 2 under NCHRP Report 350).
4. All sign spacing shall be 100m - 150m unless otherwise indicated.
5. A minimum lane width of 3.5m is required.
6. Conflicting lane markings shall be removed.
7. The Sequential Arrow Board shall be located in the centre of the closed lane. An additional Sequential Arrow Board is required when traffic volumes exceed 8000 vehicles per day or when sight distance is restricted.

SEQUENTIAL ARROW BOARD

No.	REVISIONS	BY	DATE
Approved:			
 Executive Director, Technical Standards Branch			
Date:	MARCH, 2001		
TYPICAL BRIDGE SIGNING ONE LANE CLOSURE FOUR LANE DIVIDED HIGHWAY			
Prepared By: G.E.C.	Checked By: P.H.	Scale: N.T.S.	Dwg No.: TCS-B-113B LONG DURATION

NOTE: DETAILS OF WARNING/REGULATORY SIGNS SAME AS THOSE ON OTHER SIDE OF HIGHWAY

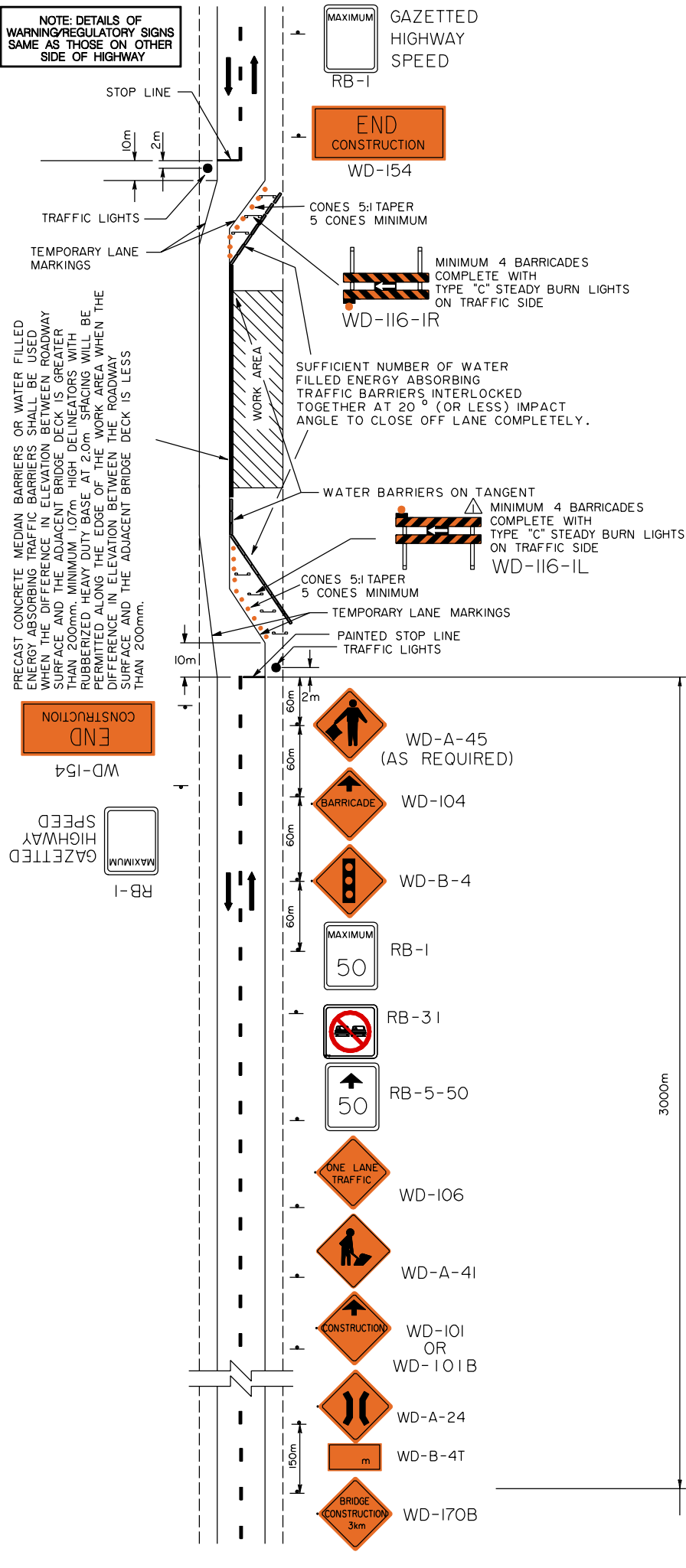

MAXIMUM
Gazetted
Highway
Speed
RB-1

END
CONSTRUCTION
WD-154

CONES 5:1 TAPER
5 CONES MINIMUM

MINIMUM 4 BARRICADES
COMPLETE WITH
TYPE "C" STEADY BURN LIGHTS
ON TRAFFIC SIDE
WD-116-IR

SUFFICIENT NUMBER OF WATER
FILLED ENERGY ABSORBING
TRAFFIC BARRIERS INTERLOCKED
TOGETHER AT 20° (OR LESS) IMPACT
ANGLE TO CLOSE OFF LANE COMPLETELY.

MINIMUM 4 BARRICADES
COMPLETE WITH
TYPE "C" STEADY BURN LIGHTS
ON TRAFFIC SIDE
WD-116-IL

CONES 5:1 TAPER
5 CONES MINIMUM

TEMPORARY LANE MARKINGS

PAINTED STOP LINE
TRAFFIC LIGHTS

END
CONSTRUCTION
WD-154

MAXIMUM
Gazetted
Highway
Speed
RB-1

WD-A-45
(AS REQUIRED)

WD-104

WD-B-4

MAXIMUM
50
RB-1

RB-31

50
RB-5-50

ONE LANE
TRAFFIC
WD-106

WD-A-41

CONSTRUCTION
WD-101
OR
WD-101B

WD-A-24

m
WD-B-4T

BRIDGE
CONSTRUCTION
3km
WD-170B

NOTES:

1. Consideration must be given to traffic volume, sight distances, sign spacing, duration of work, night time conditions and other factors to ensure traffic control devices are adequate in each instance.
2. When switching traffic during staged construction, a specialized traffic accommodation plan is required.
3. Water filled energy absorbing traffic barriers shall be of an approved type that has been crash tested (to meet Level 2 under NCHRP Report 350).
4. All sign spacing shall be 100m-150m unless otherwise indicated
5. Traffic lights shall be 300mm diameter.
6. A minimum lane width of 3.5m is required.

No.	REVISIONS		BY	DATE
Approved:				
Executive Director, Technical Standards Branch				
Date:	MARCH, 2001			
TYPICAL BRIDGE SIGNING ONE LANE CLOSURE (ONE LANE ALTERNATING TRAFFIC) TWO LANE UNDIVIDED HIGHWAY				
Prepared By: G.E.C.	Checked By: P.H.	Scale: N.T.S.	Dwg No.:	TCS-B-114A LONG DURATION

NOTES:

1. Consideration must be given to traffic volume, sight distances, sign spacing, duration of work, night time conditions and other factors to ensure traffic control devices are adequate in each instance.
2. All sign spacing shall be 100m-150m unless otherwise indicated.
3. Conflicting lane markings must be removed.
4. See other typical drawings for advance signing.
5. During darkness, two type 'A' flashing lights shall be placed on each barricade.

— LEGEND —

TEMPORARY PAVEMENT MARKING DETAILS	
	YELLOW EDGE LINES FOR CRITICAL AREAS WHERE CROSSING IS PROHIBITED
	WHITE EDGE LINES AND LANE DIVIDING LINES PROHIBITING LANE CHANGE

- DELINEATOR POSTS WITH LARGE BASES
- ⊢ BARRICADES
- ⊙ LARGE CONES

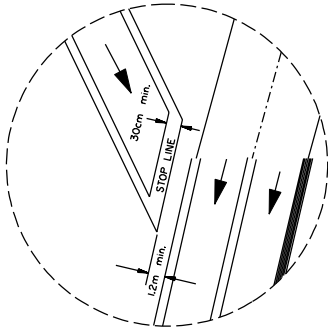

DETAIL 'A'

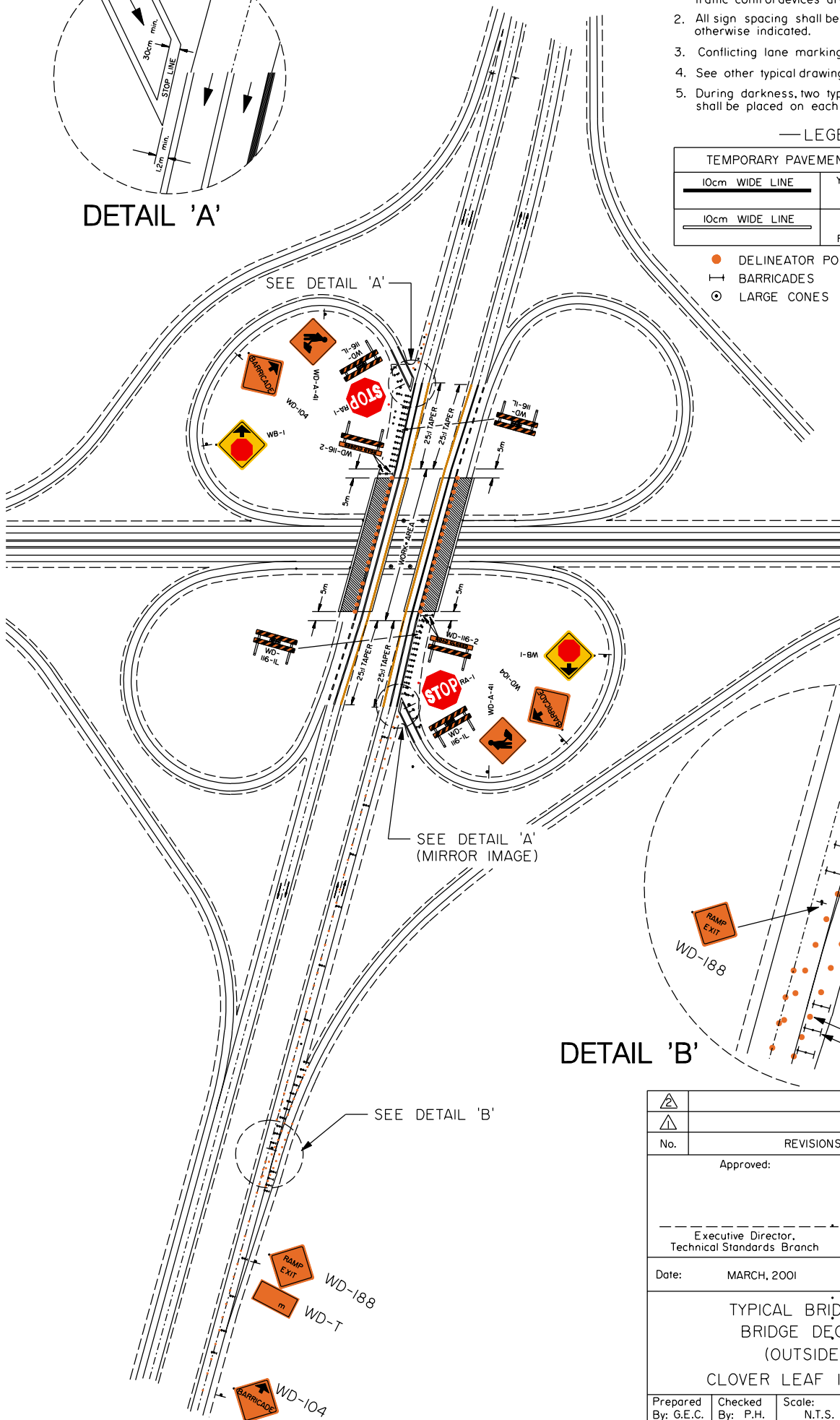

DETAIL 'B'

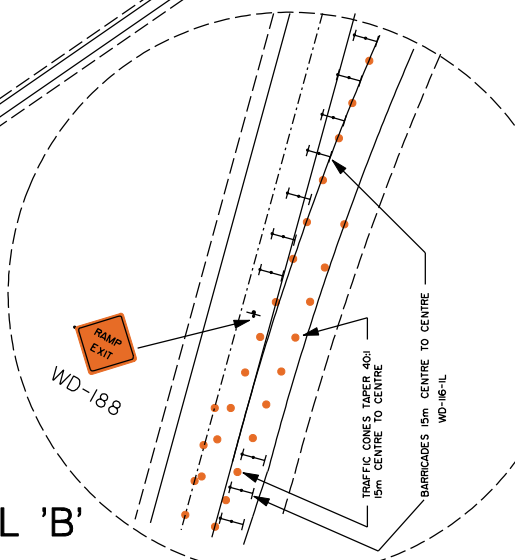





No.	REVISIONS	BY	DATE
Approved:			
Executive Director, Technical Standards Branch			
Date:	MARCH, 2001		
TYPICAL BRIDGE SIGNING BRIDGE DECK REPAIR (OUTSIDE LANE) CLOVER LEAF INTERCHANGES			
Prepared By: G.E.C.	Checked By: P.H.	Scale: N.T.S.	Dwg No.: TCS-B-115B LONG DURATION

NOTES:

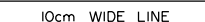

1. Consideration must be given to traffic volume, sight distances, sign spacing, duration of work, night time conditions and other factors to ensure traffic control devices are adequate in each instance.
2. All sign spacing shall be 100m-150m unless otherwise indicated.
3. Conflicting lane markings must be removed.
4. See other typical drawings for advance signing.
5. During darkness, two type 'A' flashing lights shall be placed on each barricade.

— LEGEND —

TEMPORARY PAVEMENT MARKING DETAILS	
	YELLOW EDGE LINES FOR CRITICAL AREAS WHERE CROSSING IS PROHIBITED
	WHITE EDGE LINES AND LANE DIVIDING LINES PROHIBITING LANE CHANGE

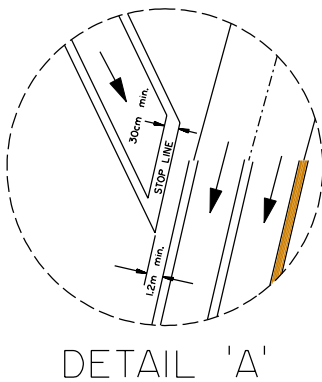
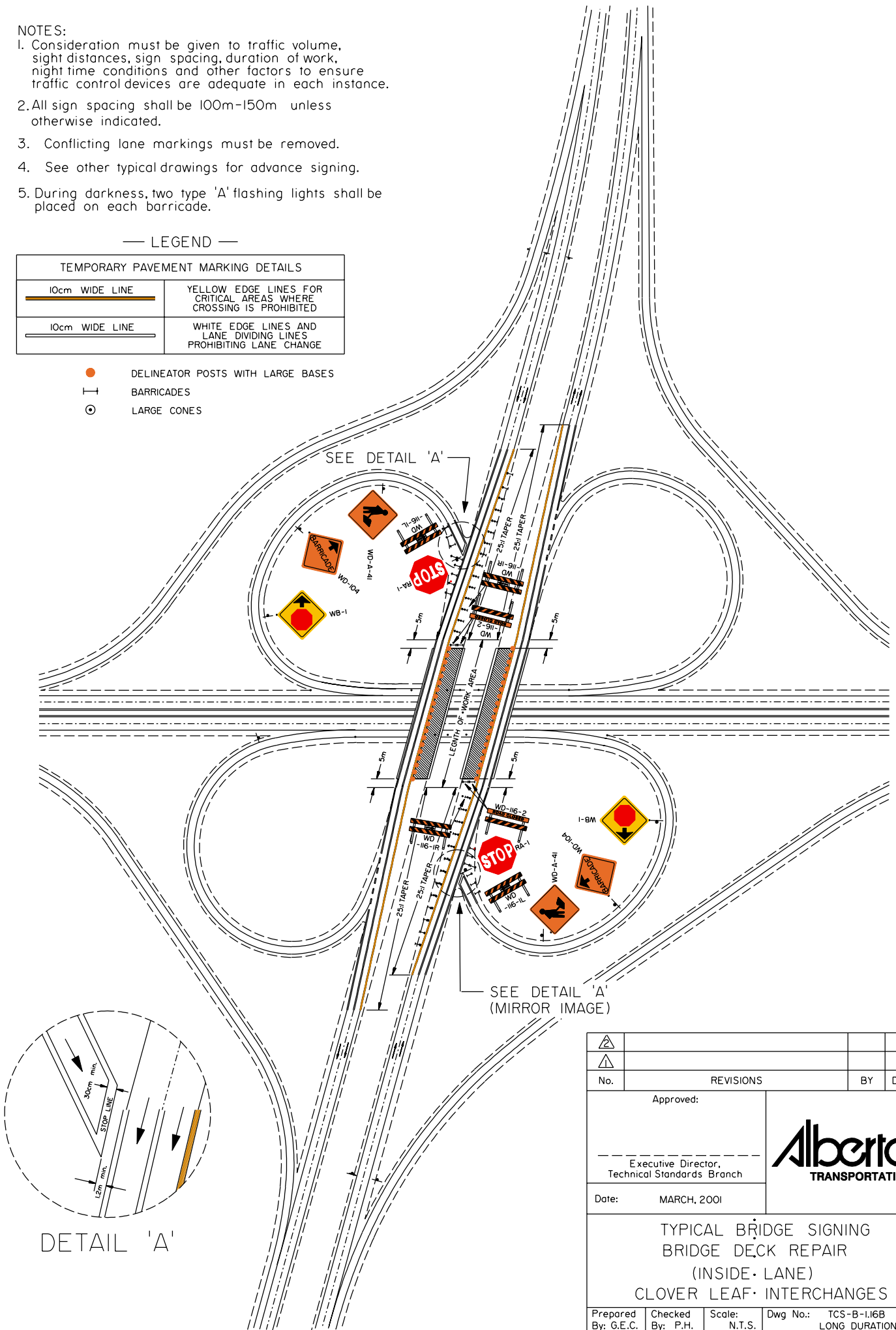
-  DELINEATOR POSTS WITH LARGE BASES
-  BARRICADES
-  LARGE CONES



			
			
No.	REVISIONS	BY	DATE
Approved:			
Executive Director, Technical Standards Branch			
Date:	MARCH, 2001		
TYPICAL BRIDGE SIGNING BRIDGE DECK REPAIR (INSIDE LANE) CLOVER LEAF INTERCHANGES			
Prepared By: G.E.C.	Checked By: P.H.	Scale: N.T.S.	Dwg No.: TCS-B-116B LONG DURATION

NOTE:
 DETAILS OF
 WARNING/REGULATORY
 SIGNS SAME AS
 THOSE ON OTHER
 SIDE OF HIGHWAY.

CONES 40:1 TAPER
 15m SPACING

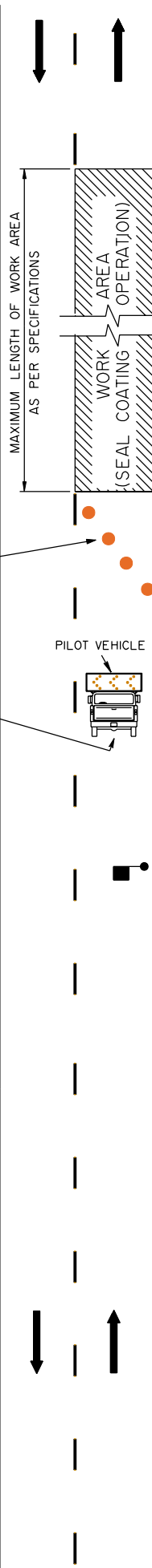

WD-173
 PILOT VEHICLE
 DO NOT PASS
 INSTALL ON REAR OF
 PILOT VEHICLE

- RB-1 GAZETTED HIGHWAY SPEED
- END CONSTRUCTION WD-154
- WD-174 (MAXIMUM LOOSE CHIPS)
- WD-174 (MAXIMUM LOOSE CHIPS)
- EVERY 1.6km AND AFTER ROAD ALLOWANCES
- WD-174 (MAXIMUM LOOSE CHIPS)
- INSTALL EVERY 4.8km
 LOOSE CHIPS
 PLEASE SLOW DOWN
 WD-169
- FOLLOW PILOT VEHICLE WD-172
- DO NOT PASS FOLLOW IN CONVOY WD-171
- FLAGPERSON
- WD-A-45
- RB-1 (MAXIMUM 50)
- RB-31
- WD-106 (ONE LANE TRAFFIC)
- RB-5 (MAXIMUM 50)
- VARIABLE MESSAGE (SEE NOTE 4)
- WD-A-41
- WD-101 (ROAD CONSTRUCTION)
- ROAD CONSTRUCTION NEXT _ km WD-192

NOTES:

1. Consideration must be given to traffic volume, direction of travel of seal coating operations, sight distances, sign spacing, duration of work and other factors to ensure traffic control devices are adequate in each instance.
2. All sign spacing shall be 100m-150m unless otherwise indicated.
3. Typical signing is required in both directions.
4. Variable Message Board should read either "LOOSE CHIPS MAX 50 km/h" or "LOOSE CHIPS PLEASE SLOW DOWN".
5. WD-192 shall be erected 2km in advance of the project. Distance tab to include project length plus setback from project limit.
6. Drawing TCS-B-1.7A applies when construction on the roadway has been completed but barrier lines have not yet been painted.
7. Conditions under which 'MAXIMUM 80km/hr' sign may be used are detailed in the chip seal coat specifications.

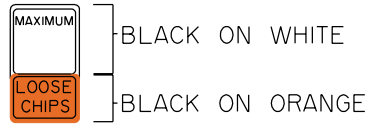

WD-174 (speed limit shown on WD-174 should be compatible with other speed limit signs used)

No.	REVISIONS	BY	DATE
Approved:			
Executive Director, Technical Standards Branch			
Date:	MARCH, 2001		
TYPICAL SIGNING CHIP SEAL COATING OPERATIONS TWO LANE UNDIVIDED HIGHWAY			
Prepared By: G.E.C.	Checked By: P.H.	Scale: N.T.S.	Dwg No.: TCS-B-1.7A LONG DURATION

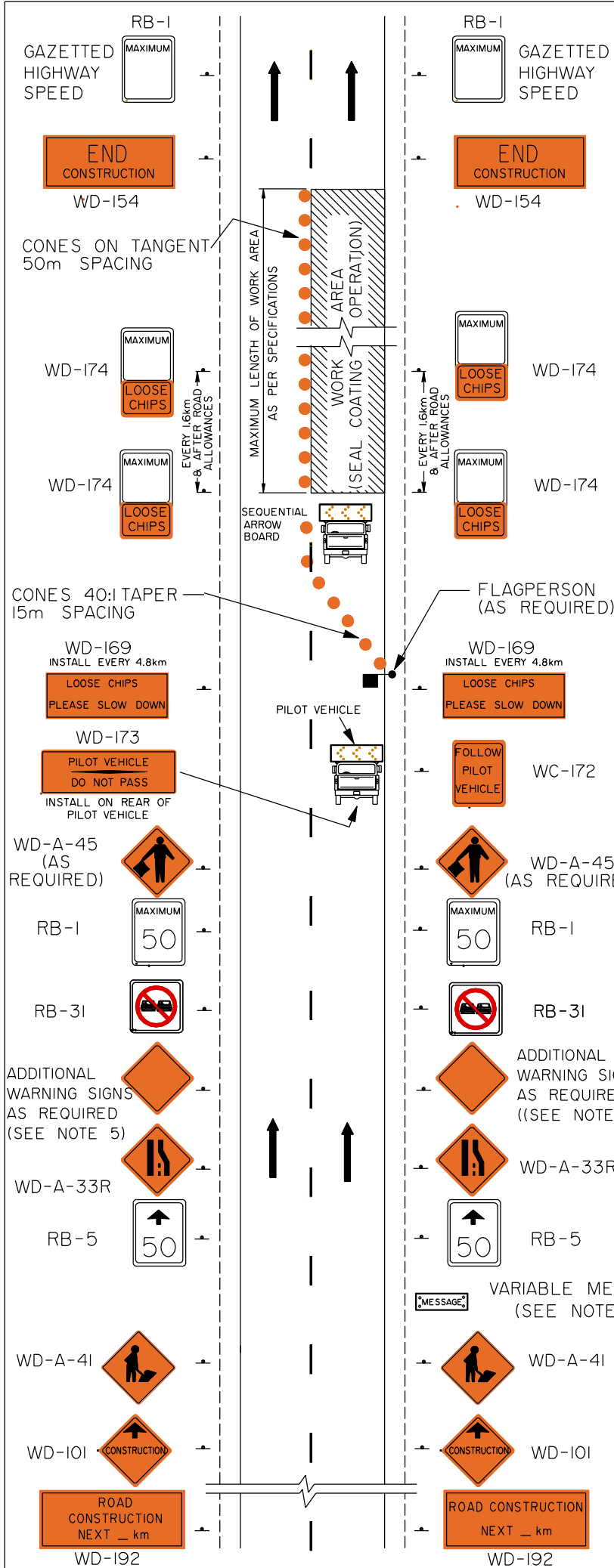

NOTES:

1. Consideration must be given to traffic volume, direction of travel of seal coating operations, sight distances, sign spacing, duration of work and other factors to ensure traffic control devices are adequate in each instance.
2. All sign spacing shall be 100m-150m unless otherwise indicated.
3. Variable Message Board message should read either "LOOSE CHIPS MAX 50 km/h" or "LOOSE CHIPS PLEASE SLOW DOWN".
4. An additional Sequential Arrow Board is required when traffic volumes exceed 8000 vehicles per day or when sight distance is restricted.
5. Examples of additional warning signs that may be required in conjunction with this plan are:
 - BARRICADE
 - LOOSE GRAVEL
 - SLOW FRESH OIL
6. WD-192 shall be erected 2km in advance of the project. Distance tab to include project length plus setback from project limit.
7. Drawing TCS-B-1.7A applies when construction on the roadway has been completed but barrier lines have not yet been painted.
8. Conditions under which 'MAXIMUM 80km/hr' sign may be used are detailed in the chip seal coat specifications.
9. Cones on tangent may not be required if alternative lane closure methods are utilized.



BLACK ON WHITE
 BLACK ON ORANGE
 WD-174 (speed limit shown on WD-174 should be compatible with other speed limit signs used)

No.	REVISIONS	BY	DATE
Approved:			
Executive Director, Technical Standards Branch			
Date:	MARCH, 2001		
TYPICAL SIGNING CHIP SEAL COATING OPERATIONS FOUR LANE DIVIDED HIGHWAY			
Prepared By: G.E.C.	Checked By: P.H.	Scale: N.T.S.	Dwg No.: TCS-B-117B LONG DURATION

NOTE:
 DETAILS OF
 WARNING/REGULATORY
 SIGNS SAME AS
 THOSE ON OTHER
 SIDE OF HIGHWAY.

CONES 40:1 TAPER
 15m SPACING

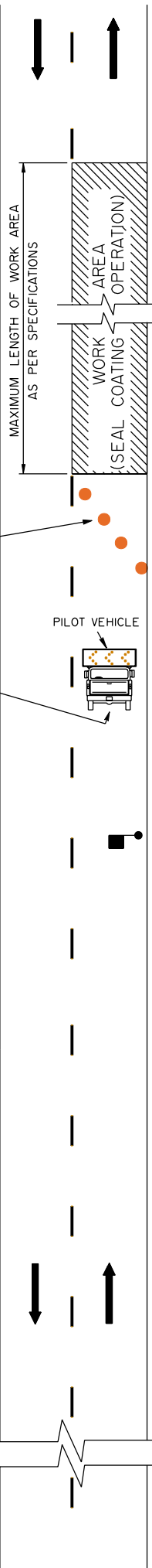

- RB-1
 GAZETTED HIGHWAY SPEED
- WD-154
 END CONSTRUCTION
- WD-174
 LOOSE CHIPS
- WD-174
 LOOSE CHIPS
- WD-169
 LOOSE CHIPS PLEASE SLOW DOWN
- WD-172
 FOLLOW PILOT VEHICLE
- WD-171
 DO NOT PASS FOLLOW IN CONVOY
- FLAGPERSON
- WD-A-45
 ONE LANE TRAFFIC
- RB-1
 50
- RB-31
 NO TRUCKS
- WD-106
 ONE LANE TRAFFIC
- RB-5
 50
- WD-A-41
 ONE LANE TRAFFIC
- WD-101
 CONSTRUCTION
- WD-192
 ROAD CONSTRUCTION NEXT _ km

- NOTES:
1. Consideration must be given to traffic volume, direction of travel of seal coating operations, sight distances, sign spacing, duration of work and other factors to ensure traffic control devices are adequate in each instance.
 2. All sign spacing shall be 100m-150m unless otherwise indicated.
 3. Typical signing is required in both directions.
 4. WD-192 shall be erected 2km in advance of the project. Distance tab to include project length plus setback from project limit.
 5. Drawing TCS-B-1.7A applies when construction on the roadway has been completed but barrier lines have not yet been painted.

BLACK ON WHITE
 BLACK ON ORANGE

WD-174 (speed limit shown on WD-174 should be compatible with other speed limit signs used)

No.	REVISIONS	BY	DATE
Approved:			
Executive Director, Technical Standards Branch			
Date:	MARCH, 2001		
TYPICAL SIGNING DOUBLE SEAL AND GRADED AGGREGATE SEAL COATING OPERATIONS TWO LANE UNDIVIDED HIGHWAY			
Prepared By: G.E.C.	Checked By: P.H.	Scale: N.T.S.	Dwg No.: TCS-B-1.18A LONG DURATION

TRAFFIC ACCOMMODATION IN WORK ZONES

LIST OF DRAWINGS

SHORT DURATION			
TCS-B Drawing No.	2 Lane Undivided Highway	Divided Highway	Description
2.1A	X		One Lane Closure (One Lane Alternating Traffic)
2.1B		X	One Lane Closure
2.2A	X		Work On Shoulder
2.2B		X	Work On Shoulder
2.3A	X		Work Off Road Surface
2.3B		X	Work Off Road Surface
2.4B		X	Centre And Right Lane Closure Repair/Survey/Testing/Inspection Crews (Six Lane Divided Highway)
2.5B		X	Right Lane Closure Repair/Survey/Testing/Inspection Crews (Six Lane Divided Highway)
2.6A	X		Road Top Shaping
2.7A	X		Work On Centerline Two Lane Traffic
2.8B		X	Temporary Detour Transition

WD-184
OR
WD-A-46
OR
WD-A-41

RB-31

RD-156

WD-A-45



FLAGPERSON

3km MAXIMUM

WORK AREA

CONES 5:1 TAPER
5 CONES MINIMUM

CONES ON TANGENT
50m SPACING

CONES 5:1 TAPER
5 CONES MINIMUM

FLAGPERSON



WD-A-45



RD-156



RB-31



WD-A-41
OR
WD-A-46
OR
WD-184

NOTES:

1. Consideration must be given to traffic volume, sight distances, sign spacing, duration of work and other factors to ensure traffic control devices are adequate in each instance.
2. All sign spacing shall be 100m-150m unless otherwise indicated.
3. For mobile operation, cones may not be required.



WD-A-46



WD-184

No.	REVISIONS	BY	DATE
Approved:			
Executive Director, Technical Standards Branch			
Date:	MARCH, 2001		
TYPICAL SIGNING ONE LANE CLOSURE (ONE LANE ALTERNATING TRAFFIC) TWO LANE UNDIVIDED HIGHWAY			
Prepared By: G.E.C.	Checked By: P.H.	Scale: N.T.S.	Dwg No.: TCS-B-2.1A SHORT DURATION

GAZETTED
HIGHWAY
SPEED



RB-1

CONES 5:1 TAPER
5 CONES MINIMUM

GAZETTED
HIGHWAY
SPEED



RB-1

CONES ON TANGENT
50m SPACING



SEQUENTIAL
ARROW
BOARD

CONES 40:1 TAPER
15m SPACING

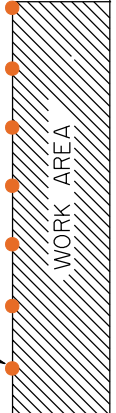

NOTES:

1. Consideration must be given to traffic volume, sight distances, sign spacing, duration of work and other factors to ensure traffic control devices are adequate in each instance.
2. All sign spacing shall be 100m-150m unless otherwise indicated.
3. For mobile operation, cones may not be required.
4. The Sequential Arrow Board shall be located in the centre of the closed lane. An additional Sequential Arrow Board is required when traffic volume exceeds 8000 vehicles per day or when sight distance is restricted.
5. If construction operation is occurring on the opposite travel lane, then applicable construction signing will also be required on those lanes.
6. Examples of additional warning signs that may be required are:



WD-A-33L



WD-150



WD-A-22



WD-A-III



WD-104



WD-A-49



WD-A-100



WD-157

7. Other hazard signs as shown in the schedule of signs may be used as required.



WD-A-45
(AS REQUIRED)



WD-A-45
(AS REQUIRED)



WD-A-46



WD-184

ADDITIONAL
WARNING SIGNS
AS REQUIRED
(SEE NOTE 6)



ADDITIONAL
WARNING SIGNS
AS REQUIRED
(SEE NOTE 6)



RB-1



RB-1



RB-31



RB-31



WD-A-33R



WD-A-33R



RB-5



RB-5



WD-A-41
OR
WD-A-46
OR
WD-184



WD-A-41
OR
WD-A-46
OR
WD-184



③			
②			
①			
No.	REVISIONS	BY	DATE
Approved:			
Executive Director, Technical Standards Branch			
Date:	MARCH, 2001		
TYPICAL SIGNING			
ONE LANE CLOSURE			
FOUR LANE DIVIDED HIGHWAY			
Prepared By: G.E.C.	Checked By: P.H.	Scale: N.T.S.	Dwg No.: TCS-B-2.1B SHORT DURATION

WD-A-41
or
WD-A-46
or
WD-184

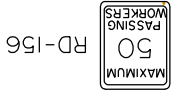

NOTES:

1. Consideration must be given to traffic volume, sight distances, sign spacing, duration of work and other factors to ensure traffic control devices are adequate in each instance.
2. All sign spacing shall be 100m-150m unless otherwise indicated.
3. For mobile operation, cones may not be required.



WD-A-46



WD-184

CONES ON TANGENT
50m SPACING

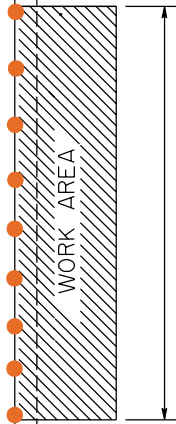

RD-156



WD-A-41
or
WD-A-46
or
WD-184

No.	REVISIONS	BY	DATE
Approved:			
Executive Director, Technical Standards Branch			
Date:	MARCH, 2001		
TYPICAL SIGNING WORK ON SHOULDER TWO LANE UNDIVIDED HIGHWAY			
Prepared By: G.E.C.	Checked By: P.H.	Scale: N.T.S.	Dwg No.: TCS-B-2.2A SHORT DURATION

NOTES:

1. Consideration must be given to traffic volume, sight distances, sign spacing, duration of work and other factors to ensure traffic control devices are adequate in each instance.
2. All sign spacing shall be 100m-150m unless otherwise indicated.
3. For mobile operation, cones may not be required.

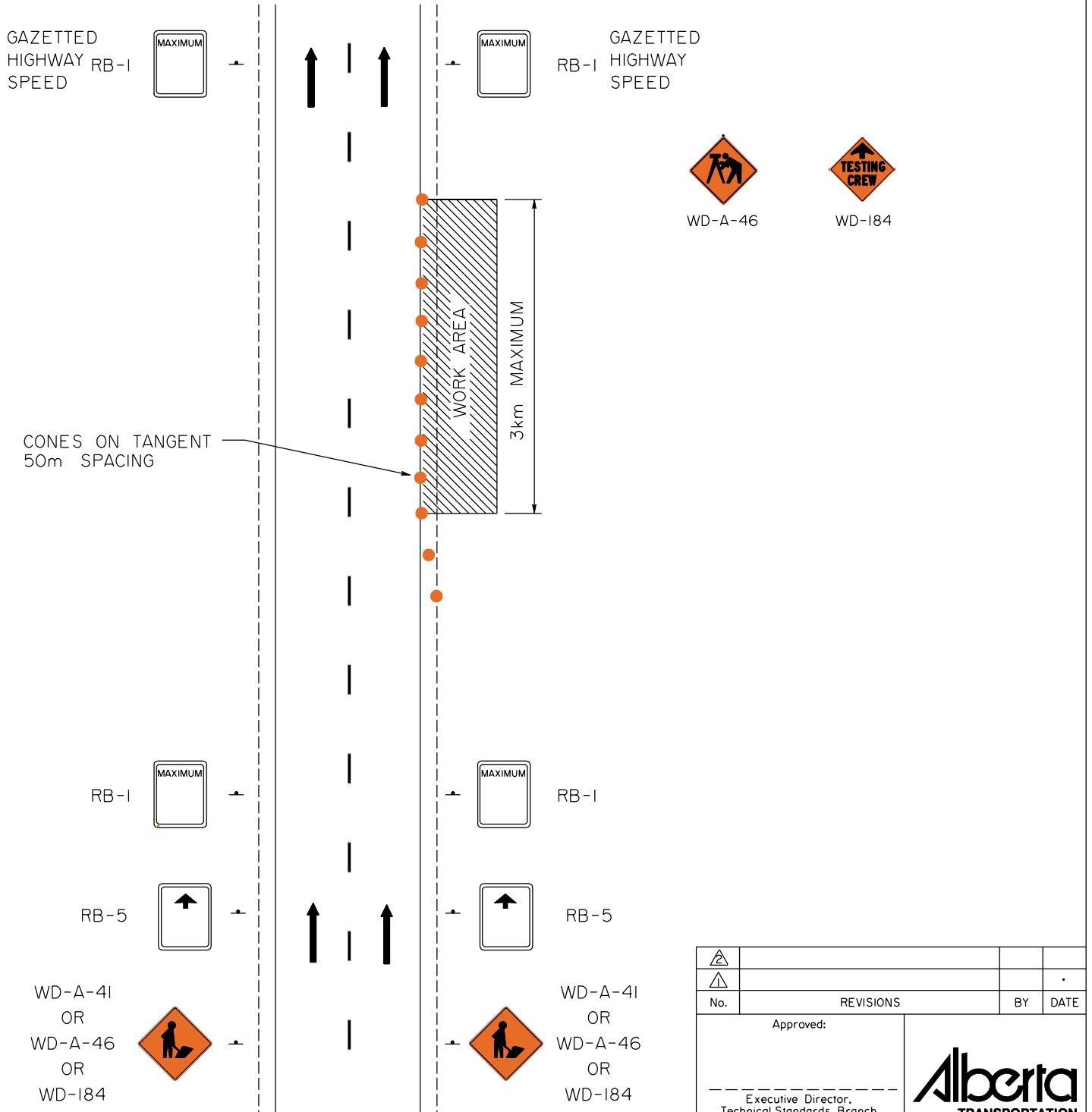

No.	REVISIONS	BY	DATE
Approved:			
Executive Director, Technical Standards Branch			
Date:	MARCH, 2001		
TYPICAL SIGNING WORK ON SHOULDER FOUR LANE DIVIDED HIGHWAY			

Prepared By: G.E.C.	Checked By: P.H.	Scale: N.T.S.	Dwg No.: TCS-B-2.2B SHORT DURATION
---------------------	------------------	---------------	---------------------------------------

WD-A-41
OR
WD-A-46
OR
WD-184



WORK AREA

HIGHWAY R/W

3km MAXIMUM



WD-A-41
OR
WD-A-46
OR
WD-184

NOTES:

- I. No vehicle shall be parked on the road surface.



WD-A-46



WD-184

No.	REVISIONS	BY	DATE
Approved:			
----- Executive Director, Technical Standards Branch			
Date:	MARCH, 2001		
TYPICAL SIGNING WORK OFF ROAD SURFACE TWO LANE UNDIVIDED HIGHWAY			
Prepared By: G.E.C.	Checked By: P.H.	Scale: N.T.S.	Dwg No.: TCS-B-2.3A SHORT DURATION

NOTE:

1. No vehicle shall be parked on the road surface.

3km MAXIMUM



WORK AREA

HIGHWAY
MEDIAN



WORK AREA

HIGHWAY R/W

3km MAXIMUM



WD-A-46



WD-184

WD-A-41
OR
WD-A-46
OR
WD-184



WD-A-41
OR
WD-A-46
OR
WD-184



No.	REVISIONS	BY	DATE
-----	-----------	----	------

Approved:	
Executive Director, Technical Standards Branch	
Date: MARCH, 2001	

TYPICAL SIGNING
WORK OFF ROAD SURFACE
FOUR LANE DIVIDED HIGHWAY

Prepared By: G.E.C.	Checked By: P.H.	Scale: N.T.S.	Dwg No.: TCS-B-2.3B SHORT DURATION
---------------------	------------------	---------------	---------------------------------------

GAZETTED
HIGHWAY
SPEED



RB-1

GAZETTED
HIGHWAY
SPEED



RB-1

NOTES:

1. Consideration must be given to traffic volume, sight distances, sign spacing, duration of work and other factors to ensure traffic control devices are adequate in each instance.
2. All sign spacing shall be 100m-150m unless otherwise indicated.
3. The Sequential Arrow Boards shall be located in the centre of the closed lanes. An additional Sequential Arrow Board is required when traffic volume exceeds 8000 vehicles per day or when sight distance is restricted.

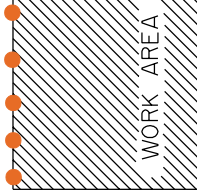

SEQUENTIAL
ARROW
BOARD

3km
MAXIMUM

CONES 40:1
TAPER 15m SPACING

CONES ON TANGENT
50m SPACING



WD-A-33R

SEQUENTIAL
ARROW
BOARD



WD-A-33R

CONES 40:1
TAPER 15m SPACING

WD-A-45
(AS
REQUIRED)



RB-1



WD-A-33XR



RB-5



RB-31



WD-A-41 OR
WD-184 OR
WD-A-46



WD-A-45
(AS REQUIRED)



RB-1



WD-A-33XR



RB-5



RB-31



WD-A-41 OR
WD-184 OR
WD-A-46



WD-A-46



WD-184

No.	REVISIONS	BY	DATE
Approved:			
Executive Director, Technical Standards Branch			
Date:	MARCH, 2001		
TYPICAL SIGNING CENTRE AND RIGHT LANE CLOSURE REPAIR/SURVEY/TESTING/INSPECTION CREWS SIX LANE DIVIDED HIGHWAY			
Prepared By: G.E.C.	Checked By: P.H.	Scale: N.T.S.	Dwg No.: TCS-B-2.4B SHORT DURATION

RB-1
GAZETTED
HIGHWAY
SPEED

RB-1
GAZETTED
HIGHWAY
SPEED

NOTES:

1. Consideration must be given to traffic volume, sight distances, sign spacing, duration of work and other factors to ensure traffic control devices are adequate in each instance.
2. All sign spacing shall be 100m-150m unless otherwise indicated.
3. The Sequential Arrow Board shall be located in the centre of the closed lane. An additional Sequential Arrow Board is required when traffic volume exceeds 8000 vehicles per day or when sight distance is restricted.

CONES ON TANGENT
50m SPACING

CONES 40:1 TAPER
15m SPACING

WD-A-45
(AS REQUIRED)



WD-A-45
(AS REQUIRED)



RB-1



RB-1



WD-A-33XR



WD-A-33XR



RB-5



RB-5



WD-A-41 OR
WD-184 OR
WD-A-46



WD-A-41 OR
WD-184 OR
WD-A-46



WD-A-46



WD-184

SEQUENTIAL
ARROW
BOARD



No.	REVISIONS	BY	DATE
Approved:			
Executive Director, Technical Standards Branch			
Date:	MARCH, 2001		
TYPICAL SIGNING RIGHT LANE CLOSURE REPAIR/SURVEY/TESTING/INSPECTION CREWS SIX LANE DIVIDED HIGHWAY			
Prepared By: G.E.C.	Checked By: P.H.	Scale: N.T.S.	Dwg No.: TCS-B-2.5B SHORT DURATION

WD-191



OR

WD-193



WD-150

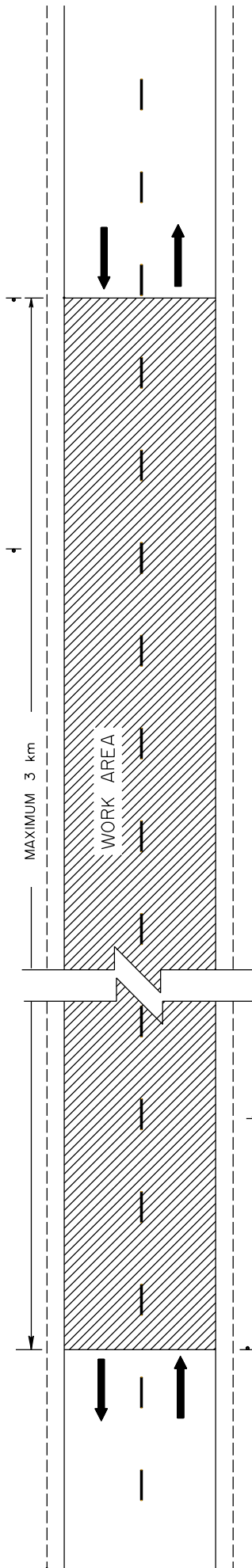

WD-150



WD-193

OR



WD-191

NOTES:

1. Consideration must be given to traffic volume, sight distances, sign spacing, duration of work and other factors to ensure traffic control devices are adequate in each instance.
2. All sign spacing shall be 100m-150m unless otherwise indicated.

No.	REVISIONS		BY DATE
Approved:			
Executive Director, Technical Standards Branch			
Date:	MARCH, 2001		
TYPICAL SIGNING ROAD TOP SHAPING TWO LANE UNDIVIDED HIGHWAY			
Prepared By: G.E.C.	Checked By: P.H.	Scale: N.T.S.	Dwg No.: TCS-B-2.6A SHORT DURATION

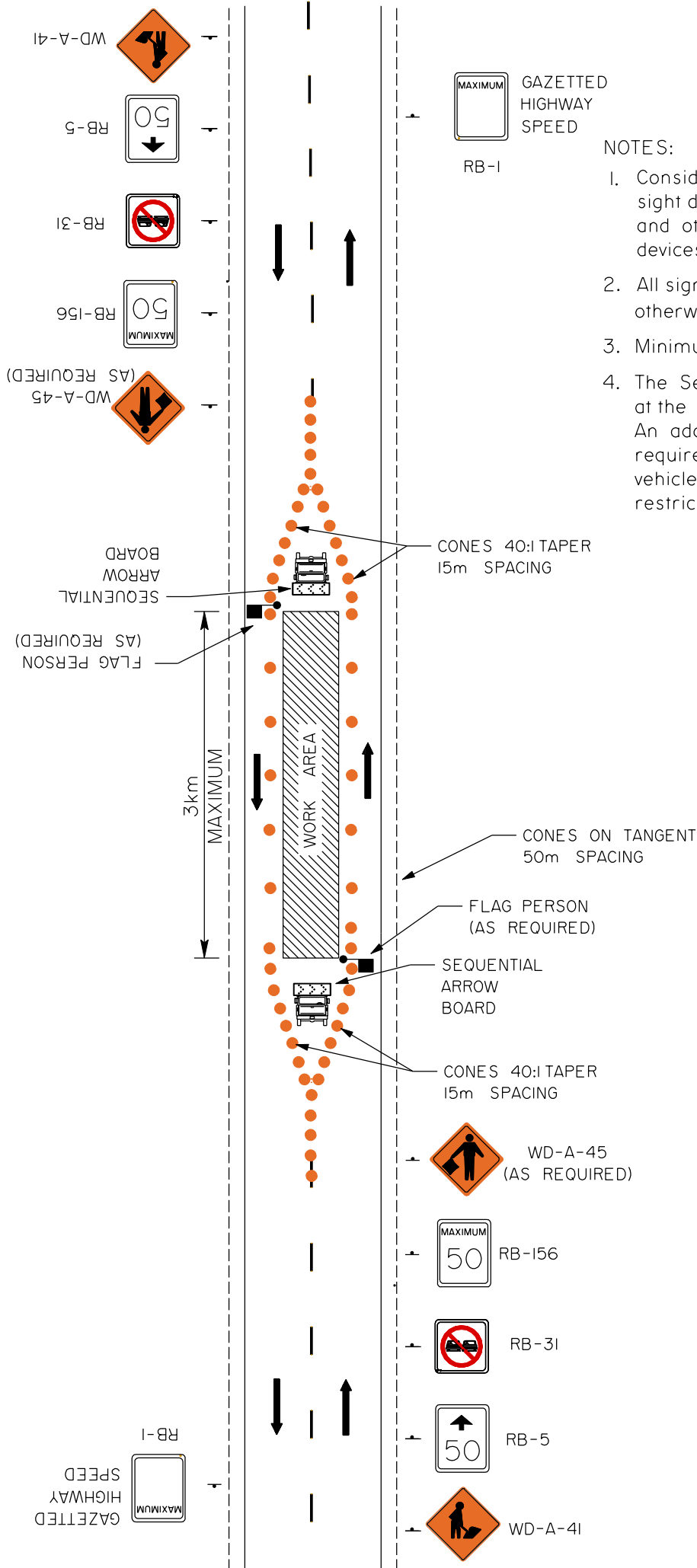

NOTES:

1. Consideration must be given to traffic volume, sight distances, sign spacing, duration of work and other factors to ensure traffic control devices are adequate in each instance.
2. All sign spacing shall be 100m-150m unless otherwise indicated.
3. Minimum lane width of 3.5m is required .
4. The Sequential Arrow Board shall be located at the centre of the closed part of the roadway. An additional Sequential Arrow Board is required when traffic volume exceeds 8000 vehicles per day or when sight distance is restricted.

No.	REVISIONS	BY	DATE
Approved: _____ Executive Director, Technical Standards Branch			
Date:	MARCH, 2001		
TYPICAL SIGNING WORK ON CENTRELINE TWO LANE TRAFFIC TWO LANE UNDIVIDED HIGHWAY			
Prepared By: G.E.C.	Checked By: P.H.	Scale: N.T.S.	Dwg No.: TCS-B-2.7A SHORT DURATION

TRAFFIC ACCOMMODATION IN WORK ZONES

LIST OF DRAWINGS

TESTING, SURVEY AND OTHER SHORT DURATION ACTIVITIES			
TCS-B Drawing No.	2 Lane Undivided Highway	4 Lane Divided Highway	Description
3.1A	X		Traffic Survey
3.1B		X	Traffic Survey
3.2A	X		Mobile Testing
3.2B		X	Mobile Testing
3.3A	X		Gravel/Oil/Road Maintenance
3.4A	X		Line Painting
3.4B		X	Line Painting

WD-179



RB-5



RB-31



RB-1



WB-1



RA-1



GAZETTED
HIGHWAY
SPEED



VARIABLE LENGTH



CONES

GAZETTED
HIGHWAY
SPEED



RA-1



WB-1



RB-1



RB-31



RB-5



WD-179

NOTES:

1. Consideration must be given to traffic volume, sight distances, sign spacing, duration of work, night time conditions and other factors to ensure traffic control devices are adequate in each instance.
2. All sign spacing shall be 100m-150m unless otherwise indicated.

Due to the specialized nature of this type of operation, a special detailed traffic accommodation strategy must be developed for each location.

No.	REVISIONS	BY	DATE
Approved:			
Executive Director, Technical Standards Branch			
Date:	MARCH, 2001		
TYPICAL SIGNING FOR TRAFFIC SURVEY TWO LANE UNDIVIDED HIGHWAY			
Prepared By: G.E.C.	Checked By: P.H.	Scale: N.T.S.	Dwg No.: TCS-B-3.1A SHORT DURATION

NOTES:

1. Consideration must be given to traffic volume, sight distances, sign spacing, duration of work, night time conditions and other factors to ensure traffic control devices are adequate in each instance.
2. All sign spacing shall be 100m-150m unless otherwise indicated.

Due to the specialized nature of this type of operation, a special detailed traffic accommodation strategy must be developed for each location.

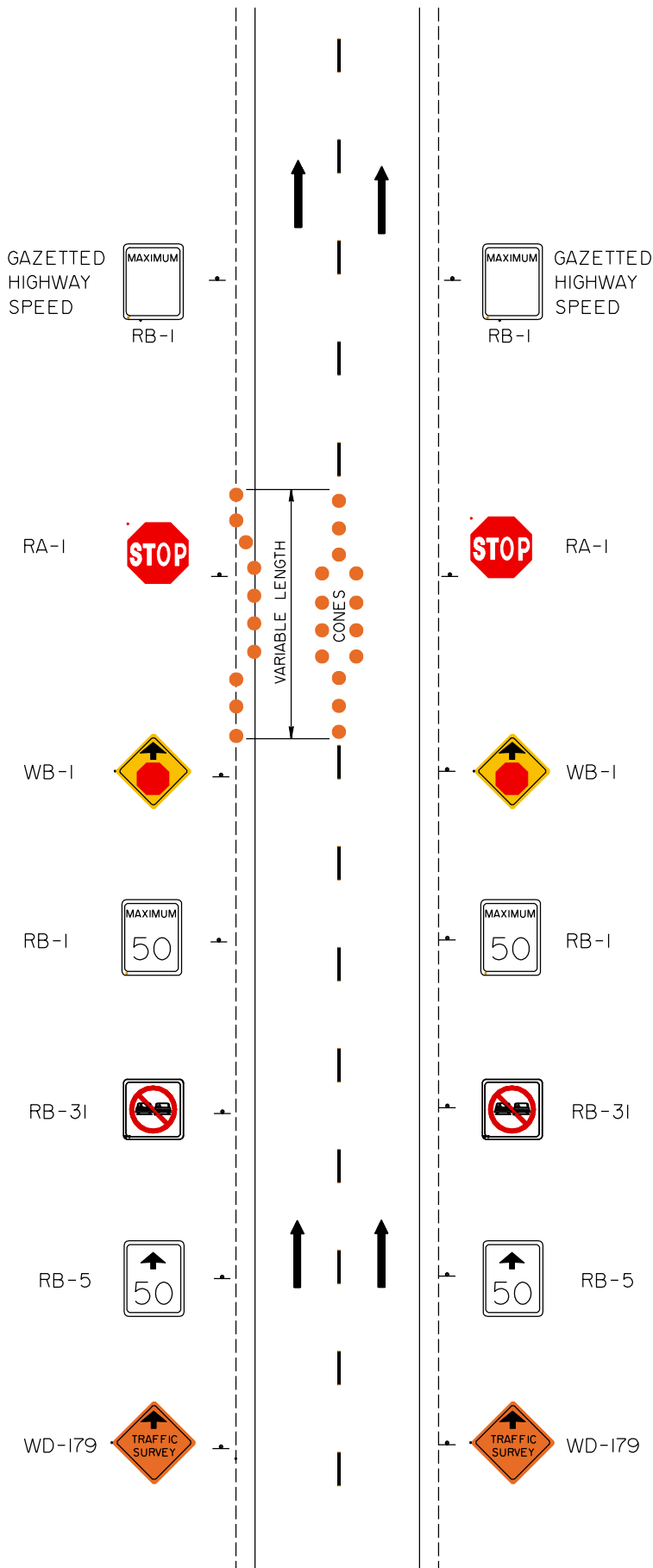

△			
△			
No.	REVISIONS	BY	DATE
Approved:			
----- Executive Director, Technical Standards Branch			
Date:	MARCH, 2001		
TYPICAL SIGNING FOR TRAFFIC SURVEY FOUR LANE DIVIDED HIGHWAY			

NOTE: DETAILS OF WARNING /REGULATORY SIGNS SAME AS THOSE ON OTHER SIDE OF HIGHWAY

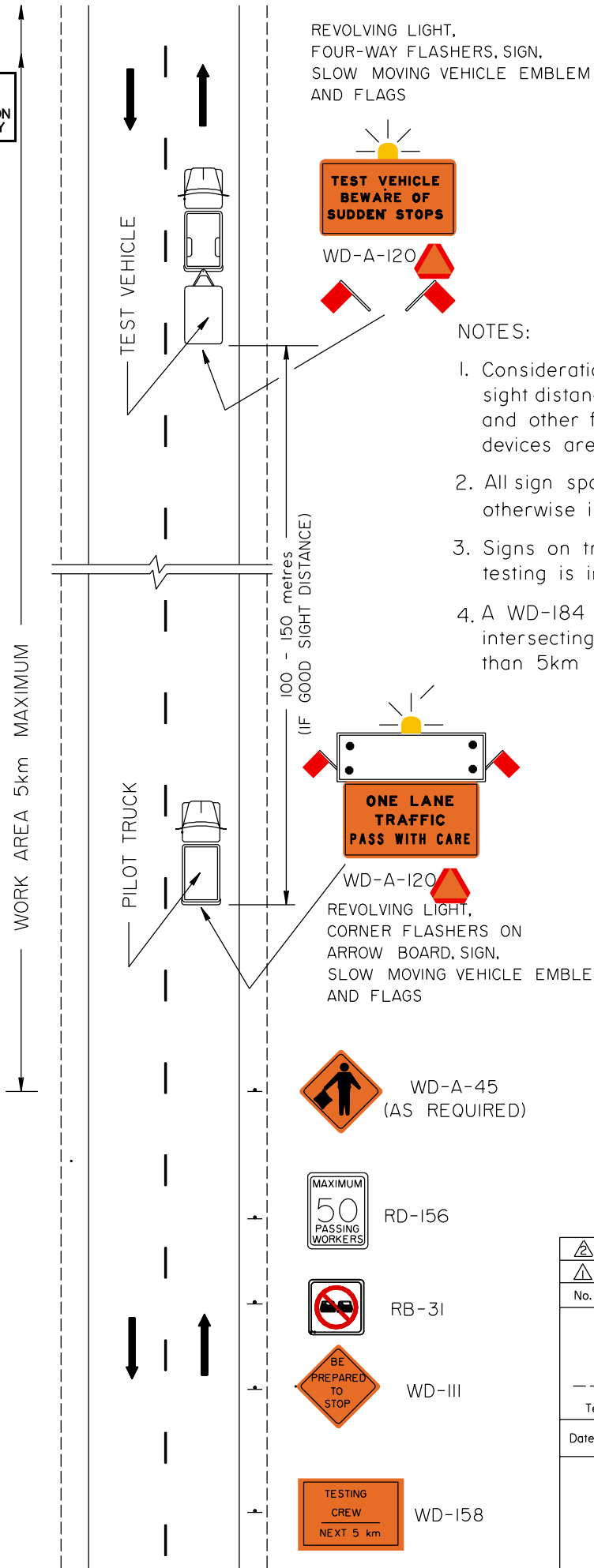

REVOLVING LIGHT,
FOUR-WAY FLASHERS, SIGN,
SLOW MOVING VEHICLE EMBLEM
AND FLAGS



WD-A-120

NOTES:

1. Consideration must be given to traffic volume, sight distances, sign spacing, duration of work and other factors to ensure traffic control devices are adequate in each instance.
2. All sign spacing shall be 100m-150m unless otherwise indicated.
3. Signs on trucks must be visible only when testing is in progress.
4. A WD-184 sign shall be placed after every intersecting roadway and shall be no more than 5km apart throughout the work area.

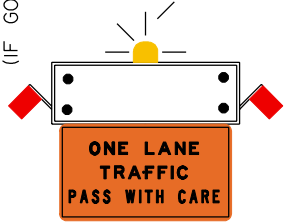

WD-A-120

REVOLVING LIGHT,
CORNER FLASHERS ON
ARROW BOARD, SIGN,
SLOW MOVING VEHICLE EMBLEM
AND FLAGS



WD-184



WD-A-45
(AS REQUIRED)



RD-156



RB-31



WD-III



WD-158

No.	REVISIONS		BY	DATE
Approved:				
_____ Executive Director, Technical Standards Branch				
Date:	MARCH, 2001			
TYPICAL SIGNING MOBILE TESTING TWO LANE UNDIVIDED HIGHWAY				
Prepared By: G.E.C.	Checked By: P.H.	Scale: N.T.S.	Dwg No.: TCS-B-3.2A	SHORT DURATION

GAZETTED
HIGHWAY
SPEED



GAZETTED
HIGHWAY
SPEED



WORK AREA 5km
MAXIMUM

TEST VEHICLE

PILOT TRUCK



WD-A-120

REVOLVING LIGHT,
FOUR-WAY FLASHERS, SIGN,
SLOW MOVING VEHICLE
EMBLEM AND FLAGS

NOTES:

1. Consideration must be given to traffic volume, sight distances, sign spacing, duration of work and other factors to ensure traffic control devices are adequate in each instance.
2. All sign spacing shall be 100m-150m unless otherwise indicated.
3. Signs on trucks must be visible only when testing is in progress.
4. A WD-184 sign shall be placed after every intersecting roadway and shall be no more than 5km apart throughout the work area.
5. The Sequential Arrow Board shall be located at the centre of the closed lane. An additional Sequential Arrow Board is required when traffic volume exceeds 8000 vehicles per day or when sight distance is restricted.

100 - 150 metres
(IF GOOD SIGHT DISTANCE)

WD-184



WD-A-120

REVOLVING LIGHT,
SEQUENTIAL ARROWS BOARD, SIGN,
SLOW MOVING VEHICLE
EMBLEM AND FLAGS

RB-1



RB-1



RB-31



RB-31



WD-A-33R



WD-A-33R



RB-5



RB-5



WD-158



WD-158



No.	REVISIONS	BY	DATE
Approved:			
Executive Director, Technical Standards Branch			
Date:	MARCH, 2001		
TYPICAL SIGNING MOBILE TESTING FOUR LANE DIVIDED HIGHWAY			
Prepared By: G.E.C.	Checked By: P.H.	Scale: N.T.S.	Dwg No.: TCS-B-3.2B SHORT DURATION

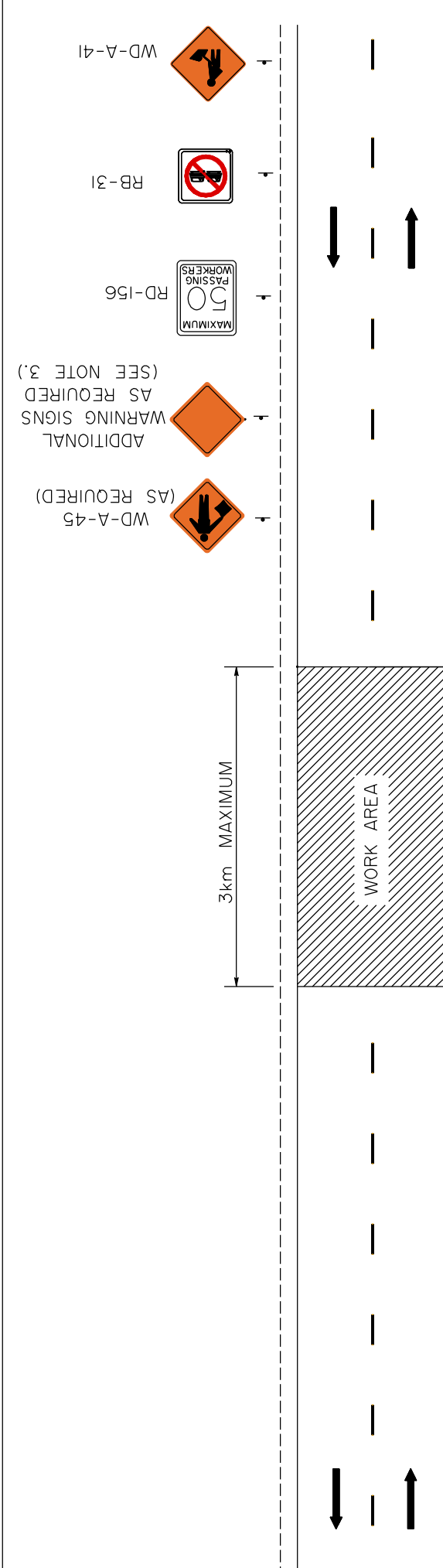

- NOTES:
1. Consideration must be given to traffic volume, sight distances, sign spacing, duration of work and other factors to ensure traffic control devices are adequate in each instance.
 2. All sign spacing shall be 100m-150m unless otherwise indicated.
 3. Speed limit and warning signs shall be placed after every intersecting roadway and shall be no more than 5 km apart throughout the work area where there is a restricted speed zone.
 4. Examples of additional warning signs that may be required are:

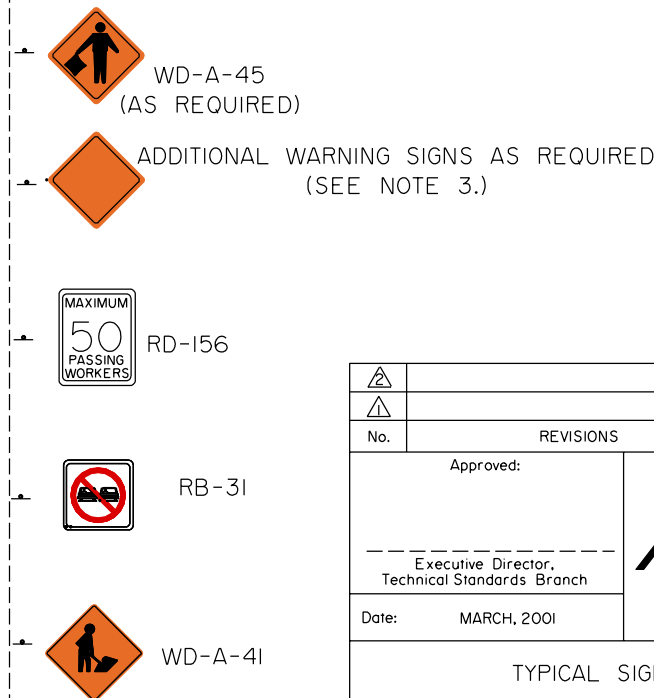

No.	REVISIONS		BY DATE
Approved:			
_____ Executive Director, Technical Standards Branch			
Date:	MARCH, 2001		
TYPICAL SIGNING GRAVEL/OIL/ROAD MAINTENANCE TWO LANE UNDIVIDED HIGHWAY			
Prepared By: G.E.C.	Checked By: P.H.	Scale: N.T.S.	Dwg No.: TCS-B-3.3A SHORT DURATION

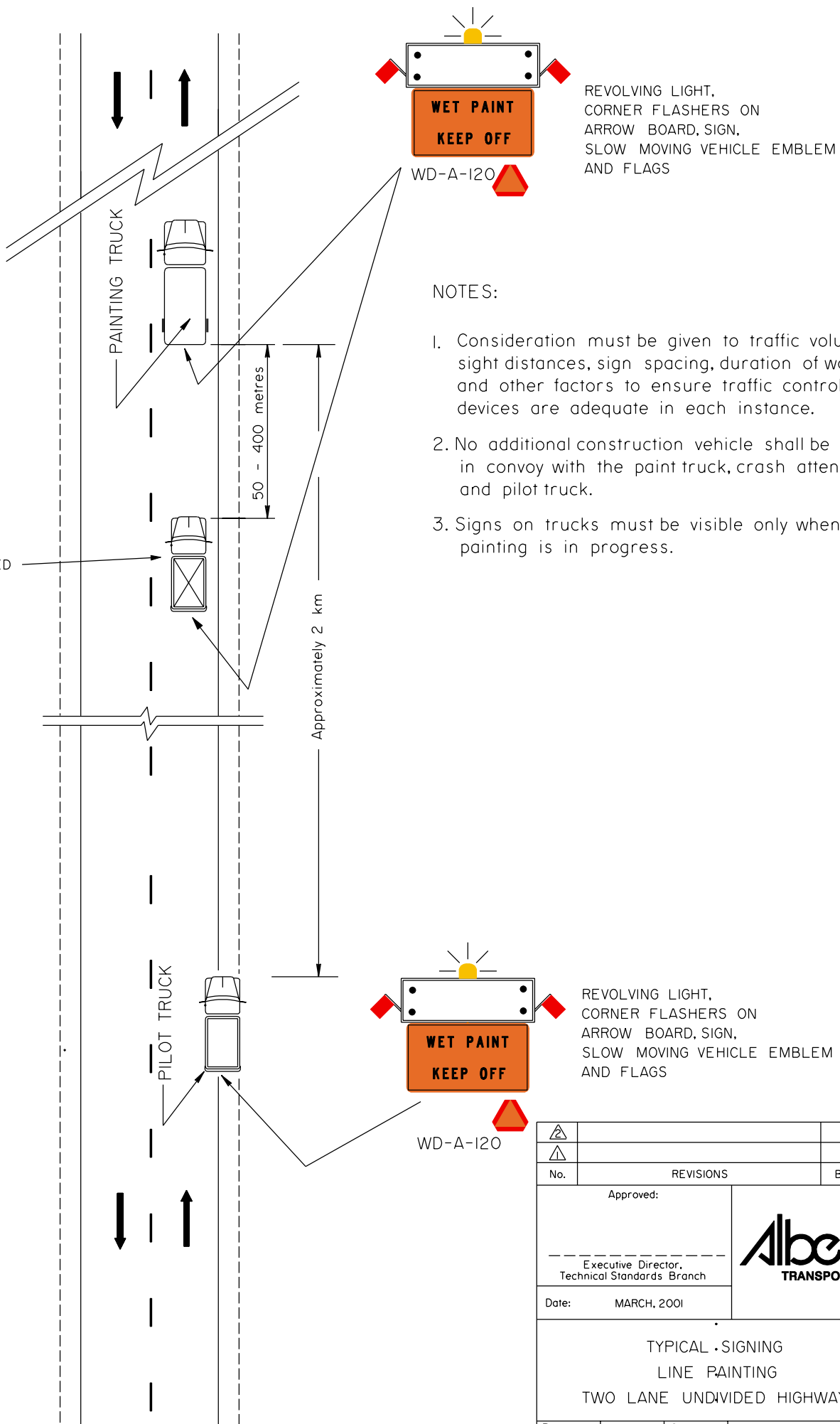

NOTES:

1. Consideration must be given to traffic volume, sight distances, sign spacing, duration of work and other factors to ensure traffic control devices are adequate in each instance.
2. No additional construction vehicle shall be driven in convoy with the paint truck, crash attenuator and pilot truck.
3. Signs on trucks must be visible only when painting is in progress.

△			
△			
No.	REVISIONS	BY	DATE
Approved:			
Executive Director, Technical Standards Branch			
Date:	MARCH, 2001		
TYPICAL SIGNING LINE PAINTING TWO LANE UNDIVIDED HIGHWAY			
Prepared By: G.E.C.	Checked By: P.H.	Scale: N.T.S.	Dwg No.: TCS-B-3.4A SHORT DURATION

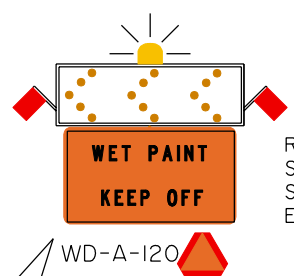
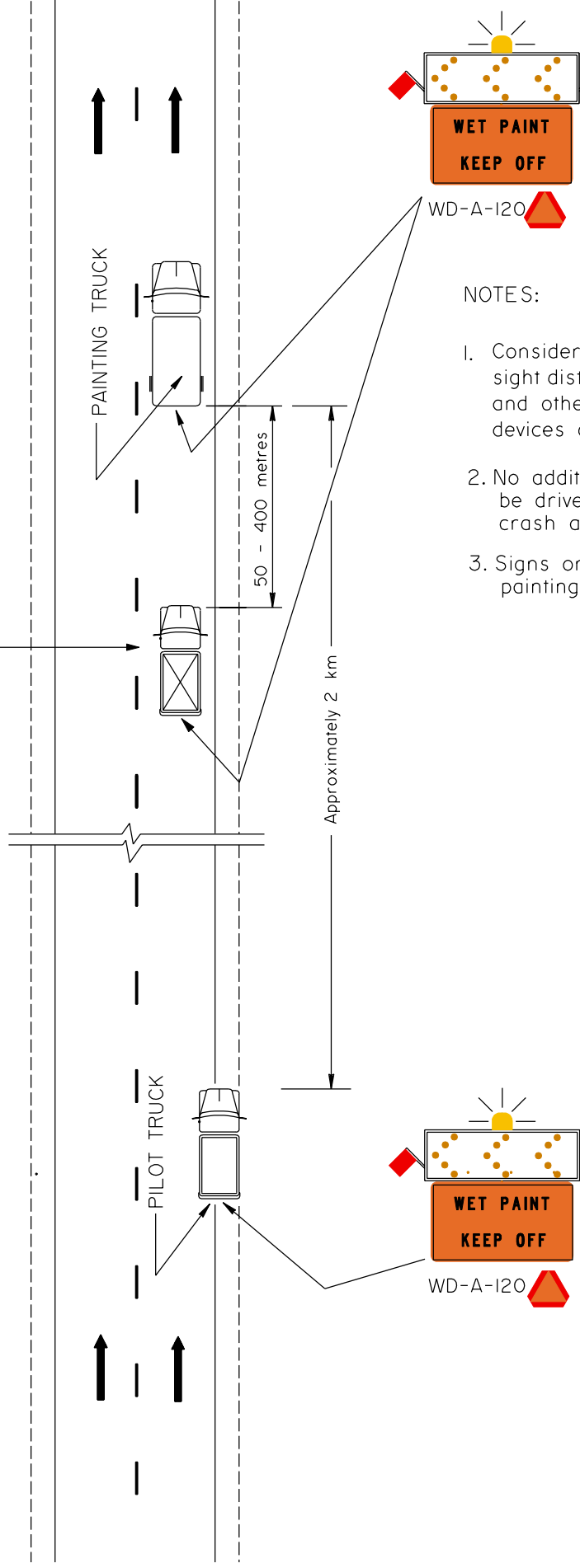

REVOLVING LIGHT,
 SEQUENTIAL ARROW BOARD, SIGN,
 SLOW MOVING VEHICLE
 EMBLEM AND FLAGS

WD-A-120

NOTES:

1. Consideration must be given to traffic volume, sight distances, sign spacing, duration of work and other factors to ensure traffic control devices are adequate in each instance.
2. No additional construction vehicle shall be driven in convoy with the paint truck, crash attenuator and pilot truck.
3. Signs on trucks must be visible only when painting is in progress.

VEHICLE EQUIPPED
 WITH CRASH
 ATTENUATOR

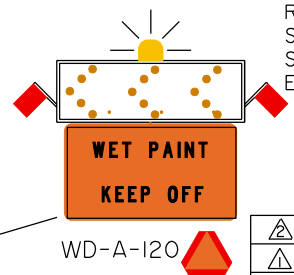

REVOLVING LIGHT,
 SEQUENTIAL ARROW BOARD, SIGN,
 SLOW MOVING VEHICLE
 EMBLEM AND FLAGS

WD-A-120

No.	REVISIONS	BY	DATE
Approved:			
----- Executive Director, Technical Standards Branch			
Date:	MARCH, 2001		

TYPICAL SIGNING
 LINE PAINTING
 FOUR LANE DIVIDED HIGHWAY

TRAFFIC ACCOMMODATION IN WORK ZONES

LIST OF DRAWINGS

MISCELLANEOUS ACTIVITIES			
TCS-B Drawing No.	2 Lane Undivided Highway	4 Lane Divided Highway	Description
4.1			Typical Barricade/Delineator Configuration Highway Transition From Four Lane Divided To Two Lane Undivided (With Temporary Stub)
4.2			Standard Barricade Used For Construction Projects
4.3			Typical Traffic Control Paddle

NOTES:

1. Consideration must be given to traffic volume, sight distances, sign spacing, duration of work and other factors to ensure traffic control devices are adequate in each instance.

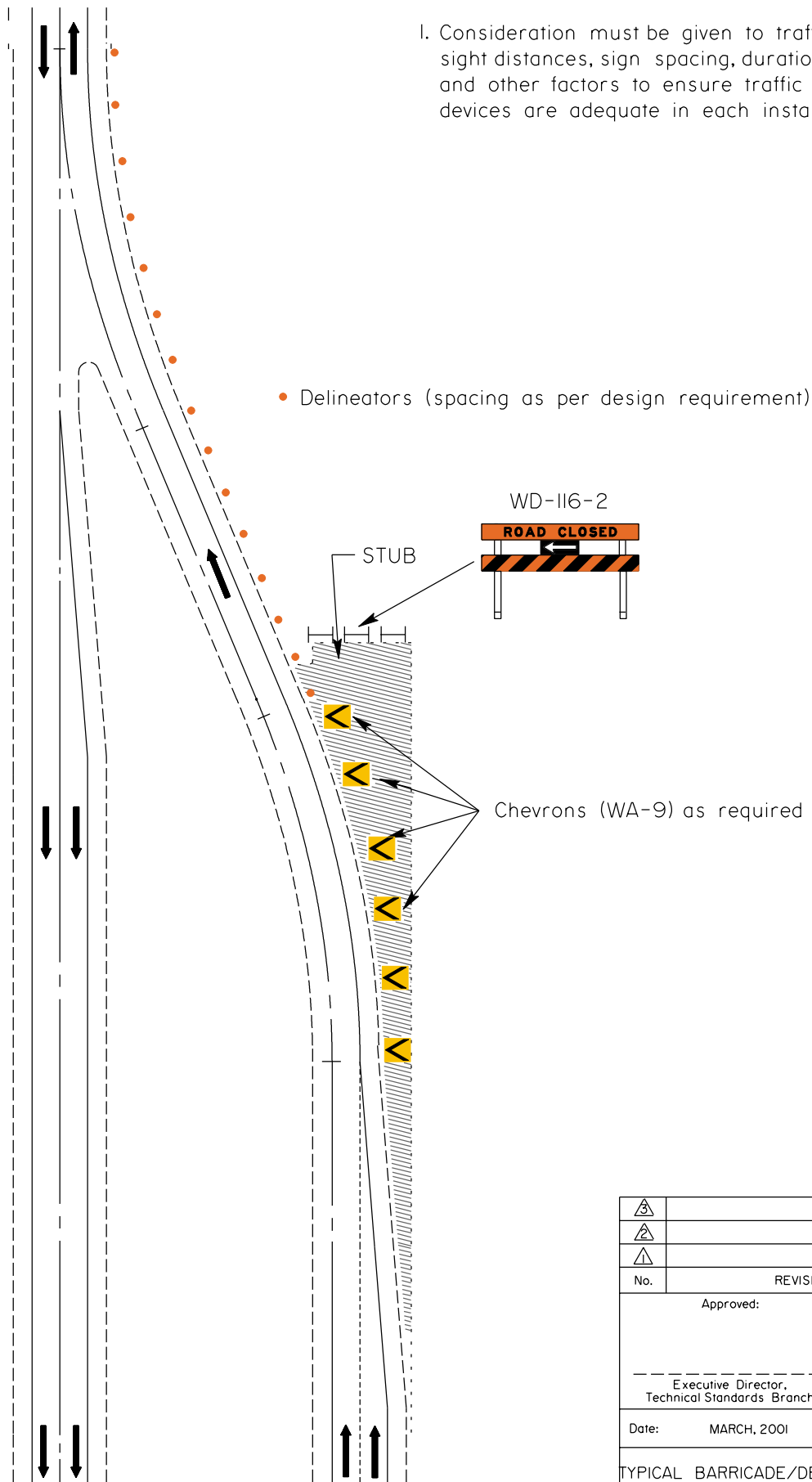

△			
△			
△			
No.	REVISIONS	BY	DATE
Approved:			
Executive Director, Technical Standards Branch			
Date:	MARCH, 2001		
TYPICAL BARRICADE/DELINEATOR CONFIGURATION HIGHWAY TRANSITION FROM FOUR LANE DIVIDED TO TWO LANE UNDIVIDED (WITH TEMPORARY STUB)			
Prepared By: G.E.C.	Checked By: P.H.	Scale: N.T.S.	Dwg No.: TCS-B-4.1 MISCELLANEOUS

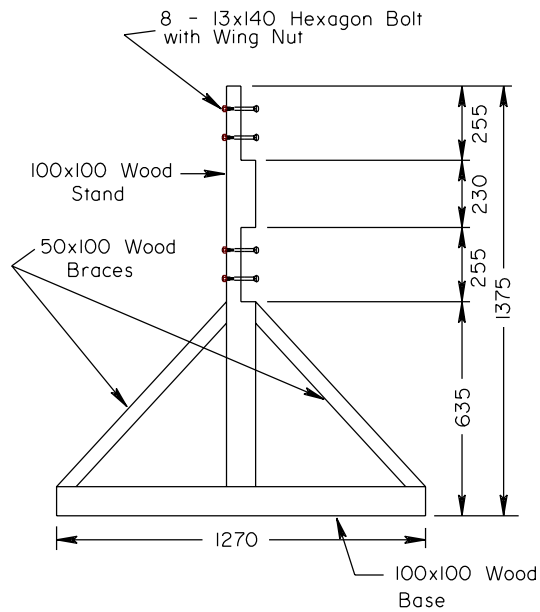
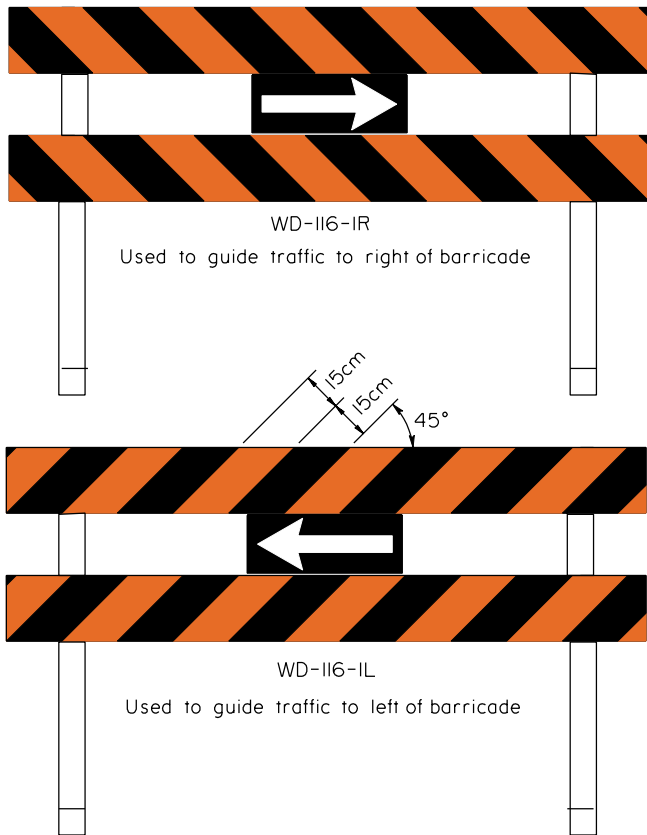

BRIDGE OUT

WD-116-3

244cm

ROAD CLOSED

25cm

WD-116-2

Bridge Out and Road Closed boards may be used to replace one diagonal stripe board where appropriate. All dimensions are in millimetres unless otherwise indicated.

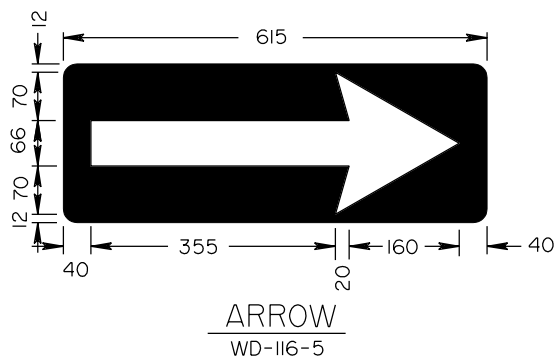

△			
△			
No.	REVISIONS	BY	DATE
Approved:			
Executive Director, Technical Standards Branch			
Date:	MARCH, 2001		
STANDARD BARRICADE USED FOR CONSTRUCTION PROJECTS			
Prepared By: G.E.C.	Checked By: P.H.	Scale: N.T.S.	Dwg No.: TCS-B-4.2 MISCELLANEOUS

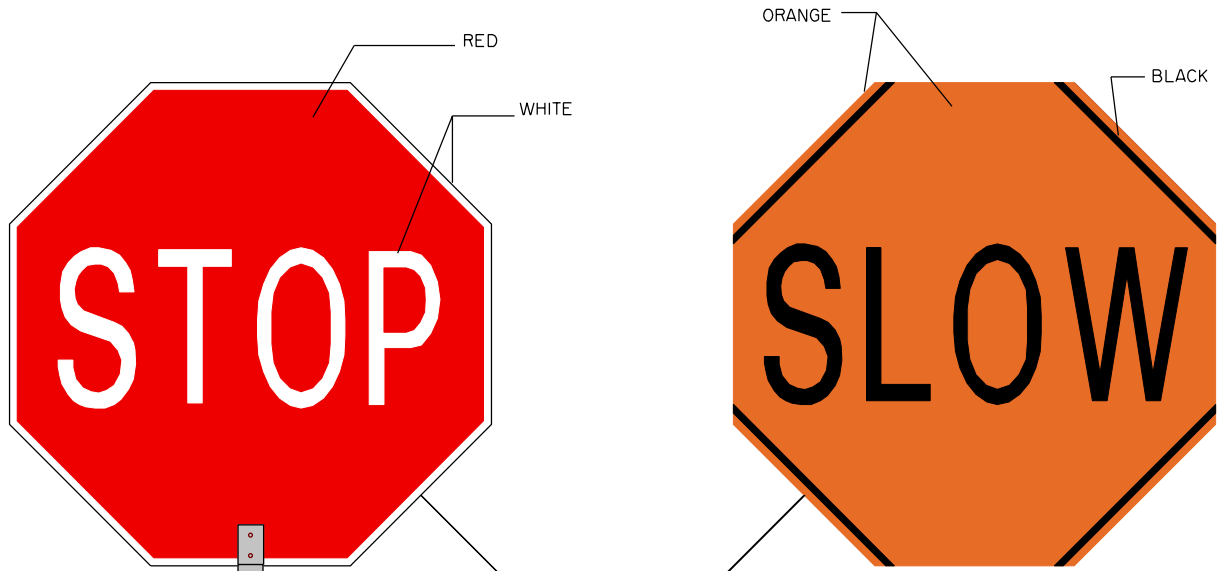

SIGN 45cm x 45cm
LETTER SIZE 150mm series "c"

HANDLE 30mm x 280mm pipe
with an insulated rubber hand grip
31.75mm Inside Diameter

Rubber cap fitted over handle of pole.

OPTIONAL POLE 30mm x 1300mm pipe
with a quick release union to fit into handle.
28.57mm Outside Diameter

No.	REVISIONS	BY	DATE
Approved:			
----- Executive Director, Technical Standards Branch			
Date:	MARCH, 2001		
TYPICAL TRAFFIC CONTROL PADDLE			
Prepared By: M.T.	Checked By: P.H.	Scale: N.T.S.	Dwg No.: TCS-B-4.3 MISCELLANEOUS

TRAFFIC ACCOMMODATION IN WORK ZONES
LIST OF DRAWINGS

UTILITIES CONSTRUCTION			
TCS-B Drawing No.	2 Lane Undivided Highway	Divided Highway	Description
5.1A	X		Work Off Road Surface
5.1B		X	Work Off Road Surface
5.2A	X		Work On Shoulder
5.2B		X	Work On Shoulder
5.3A	X		One Lane Closure (One Lane Alternating Traffic)
5.3B		X	One Lane Closure

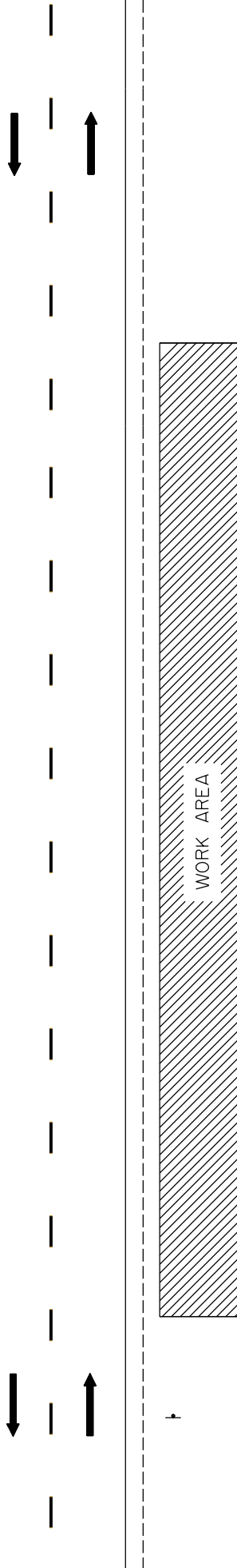
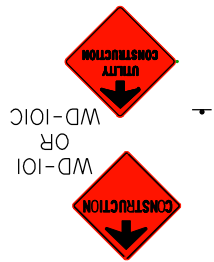

NOTES:

1. Each situation will require individual assessment, and consideration must be given to traffic volume, sight distances, sign spacing, duration of work and other factors to ensure traffic control devices are adequate in each instance.
2. All sign spacing shall be 100m-150m unless otherwise indicated.
3. No vehicles shall be parked on the road surface.
4. Materials or equipment may only be placed or stored on the outside backslope in a position to reduce damages to vehicles that may run off the roadway.
5. Effective January 1, 2002, the orange portion of all signs, barricades and other traffic control devices shall be fully reflectorized using sheeting which incorporates fluorescent pigment in conformance with Alberta Transportation specifications. Prior to January 01, 2002, any signs not meeting these requirements shall be equipped with red flags for increased visibility.
6. All signs shall be kept clean and in good condition. The bottom of the sign shall not be less than 0.3m above the road surface.
7. During periods when no work is being actively performed, all non-applicable signs are to be removed or suitably covered

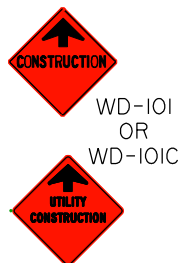

No.	REVISIONS	BY	DATE
Approved:			
Executive Director, Technical Standards Branch			
Date:	MARCH, 2001		
TYPICAL SIGNING UTILITIES CONSTRUCTION WORK OFF ROAD SURFACE TWO LANE UNDIVIDED HIGHWAY			
Prepared By: G.E.C.	Checked By: P.H.	Scale: N.T.S.	Dwg No.: TCS-B-5.1A UTILITIES CONSTRUCTION

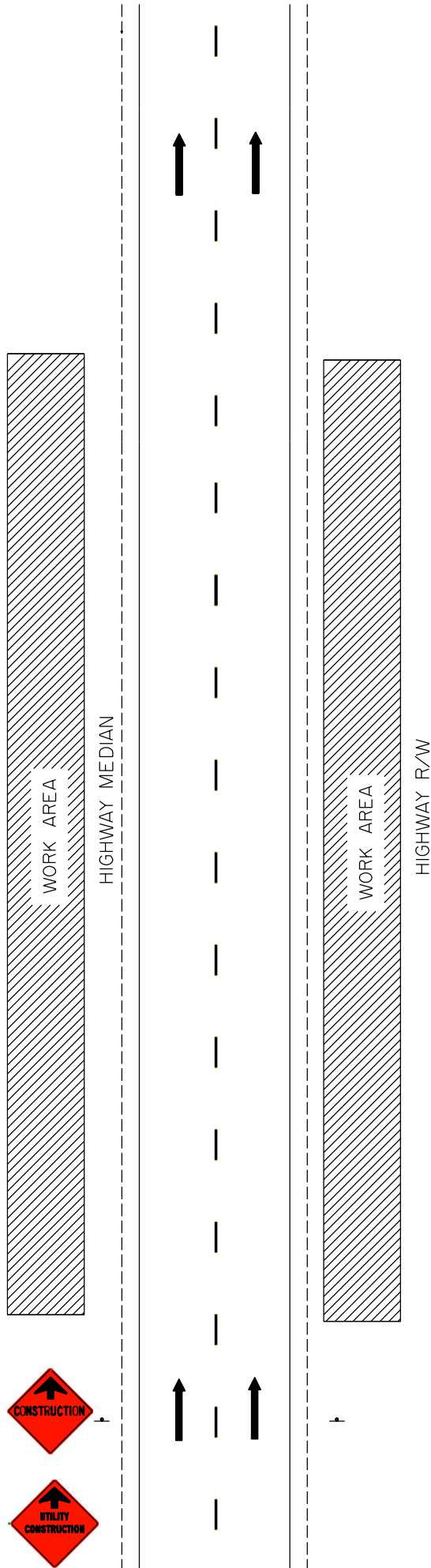

NOTES:

1. Each situation will require individual assessment, and consideration must be given to traffic volume, sight distances, sign spacing, duration of work and other factors to ensure traffic control devices are adequate in each instance.
2. All sign spacing shall be 100m-150m unless otherwise indicated.
3. No vehicles shall be parked on the road surface.
4. Materials or equipment may only be placed or stored on the outside backslope in a position to reduce damages to vehicles that may run off the roadway.
5. Materials or equipment shall not be stored in the median.
6. Effective January 1, 2002, the orange portion of all signs, barricades and other traffic control devices shall be fully reflectorized using sheeting which incorporates fluorescent pigment in conformance with Alberta Transportation specifications. Prior to January 01, 2002, any signs not meeting these requirements shall be equipped with red flags for increased visibility.
7. All signs shall be kept clean and in good condition. The bottom of the sign shall not be less than 0.3m above the road surface.
8. During periods when no work is being actively performed, all non-applicable signs are to be removed or suitably covered

No.	REVISIONS	BY	DATE
Approved:			
Executive Director, Technical Standards Branch			
Date:	MARCH, 2001		
TYPICAL SIGNING UTILITIES CONSTRUCTION WORK OFF ROAD SURFACE FOUR LANE DIVIDED HIGHWAY			
Prepared By: G.E.C.	Checked By: P.H.	Scale: N.T.S.	Dwg No.: TCS-B-5.1B UTILITIES CONSTRUCTION

NOTE:
 DETAILS OF
 WARNING/REGULATORY
 SIGNS SAME AS
 THOSE ON OTHER
 SIDE OF THE HIGHWAY

CONES ON TANGENT
 50m SPACING

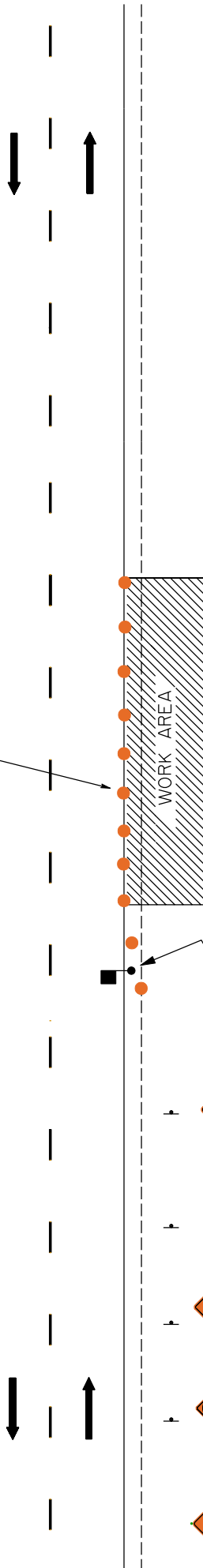

NOTES:

1. Each situation will require individual assessment, and consideration must be given to traffic volume, sight distances, sign spacing, duration of work and other factors to ensure traffic control devices are adequate in each instance.
2. All sign spacing shall be 100m-150m unless otherwise indicated.
3. No vehicles shall be parked on the driving lanes. When it is necessary to park vehicles on the shoulder of the road, they shall be marked by traffic cones.
4. If equipment is being moved across the roadway, WD-A-45 and flagperson shall be used.
5. All signs shall be kept clean and in good condition. The bottom of the sign shall not be less than 0.3m above the road surface.
6. During periods when no work is being actively performed, all non-applicable signs are to be removed or suitably covered.
7. Effective January 1, 2002, the orange portion of all signs, barricades and other traffic control devices shall be fully reflectorized using sheeting which incorporates fluorescent pigment in conformance with Alberta Transportation specifications. Prior to January 01, 2002, any signs not meeting these requirements shall be equipped with red flags for increased visibility.
8. Materials or equipment may only be placed or stored on the outside backslope in a position to reduce damages to vehicles that may run off the roadway.



WD-A-45
 (AS REQUIRED)



RD-156



WD-A-41



WD-10I
 OR
 WD-10IC



No.	REVISIONS		BY DATE
Approved:			
----- Executive Director, Technical Standards Branch			
Date:	MARCH, 2001		
TYPICAL SIGNING UTILITIES CONSTRUCTION WORK ON SHOULDER TWO LANE UNDIVIDED HIGHWAY			
Prepared By: G.E.C.	Checked By: P.H.	Scale: N.T.S.	Dwg No.: TCS-B-5.2A UTILITIES CONSTRUCTION

NOTES:

1. Each situation will require individual assessment, and consideration must be given to traffic volume, sight distances, sign spacing, duration of work and other factors to ensure traffic control devices are adequate in each instance.
2. All sign spacing shall be 100m-150m unless otherwise indicated.
3. No vehicles shall be parked on the driving lanes. When it is necessary to park vehicles on the shoulder of the road, they shall be marked by traffic cones.
4. All signs shall be kept clean and in good condition. The bottom of the sign shall not be less than 0.3m above the road surface.
5. During periods when no work is being actively performed, all non-applicable signs are to be removed or suitably covered.
6. Effective January 1, 2002, the orange portion of all signs, barricades and other traffic control devices shall be fully reflectorized using sheeting which incorporates fluorescent pigment in conformance with Alberta Transportation specifications. Prior to January 01, 2002, any signs not meeting these requirements shall be equipped with red flags for increased visibility.
7. Materials or equipment may only be placed or stored on the outside backslope in a position to reduce damages to vehicles that may run off the roadway.
8. Materials or equipment shall not be stored in the median.

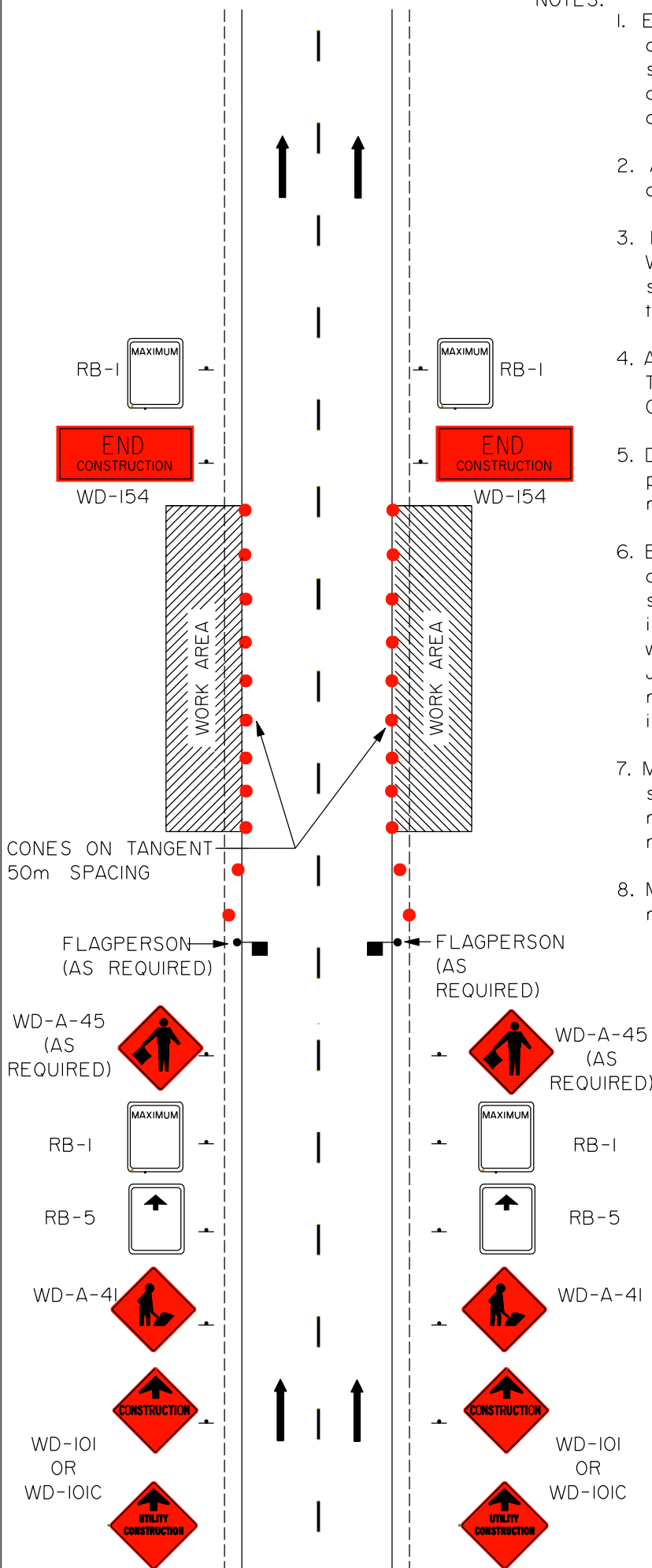

No.	REVISIONS	BY	DATE
Approved:			
Executive Director, Technical Standards Branch			
Date:	MARCH, 2001		
TYPICAL SIGNING UTILITIES CONSTRUCTION WORK ON SHOULDER FOUR LANE DIVIDED HIGHWAY			
Prepared By: G.E.C.	Checked By: P.H.	Scale: N.T.S.	Dwg No.: TCS-B-5.2B UTILITIES CONSTRUCTION

NOTES:

1. Each situation will require individual assessment, and consideration must be given to traffic volume, sight distances, sign spacing, duration of work and other factors to ensure traffic control devices are adequate in each instance.
2. All sign spacing shall be 100m-150m unless otherwise indicated.
3. All signs shall be kept clean and in good condition. The bottom of the sign shall not be less than 0.3m above the road surface.
4. During periods when no work is being actively performed, all non-applicable signs are to be removed or suitably covered.
5. Effective January 1, 2002, the orange portion of all signs, barricades and other traffic control devices shall be fully reflectorized using sheeting which incorporates fluorescent pigment in conformance with Alberta Transportation specifications. Prior to January 01, 2002, any signs not meeting these requirements shall be equipped with red flags for increased visibility.
6. Materials or equipment may only be placed or stored on the outside backslope in a position to reduce damages to vehicles that may run off the roadway.

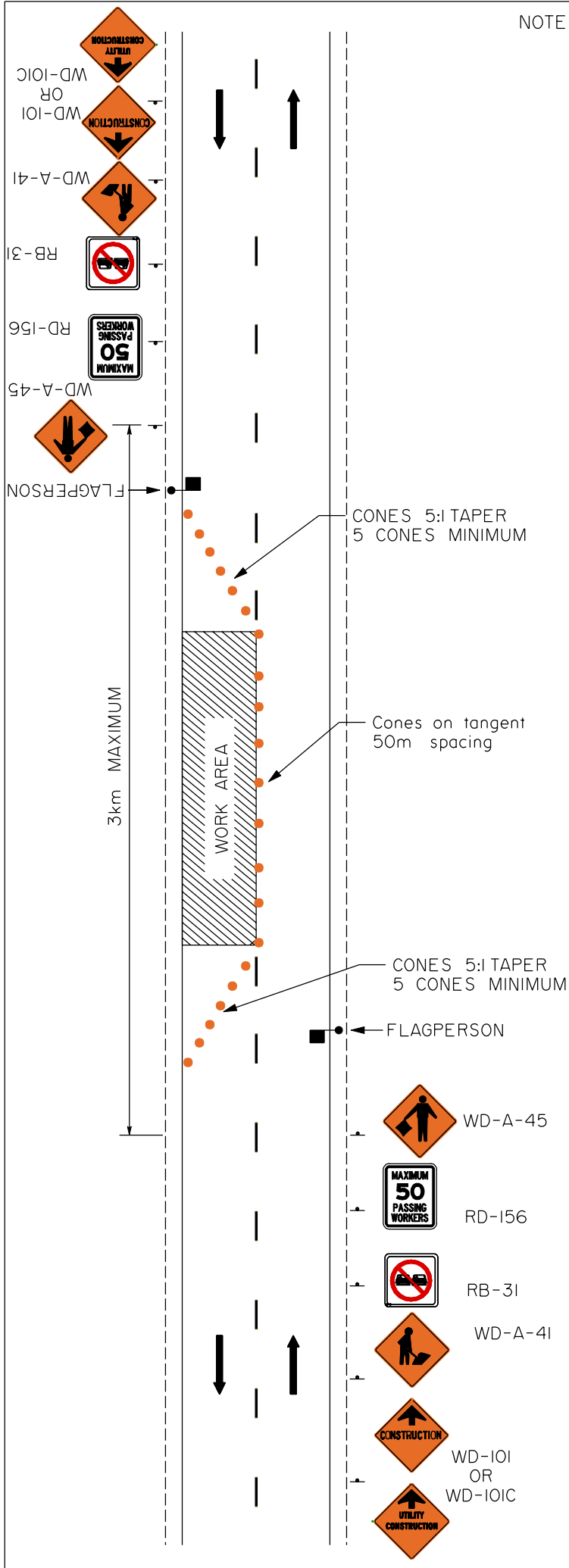

△			
△			
No.	REVISIONS	BY	DATE
Approved:			
Executive Director, Technical Standards Branch			
Date:	MARCH, 2001		
TYPICAL SIGNING UTILITIES CONSTRUCTION ONE LANE CLOSURE (ONE LANE ALTERNATING TRAFFIC) TWO LANE UNDIVIDED HIGHWAY			
Prepared By: G.E.C.	Checked By: P.H.	Scale: N.T.S.	Dwg No.: TCS-B-5.3A UTILITIES CONSTRUCTION

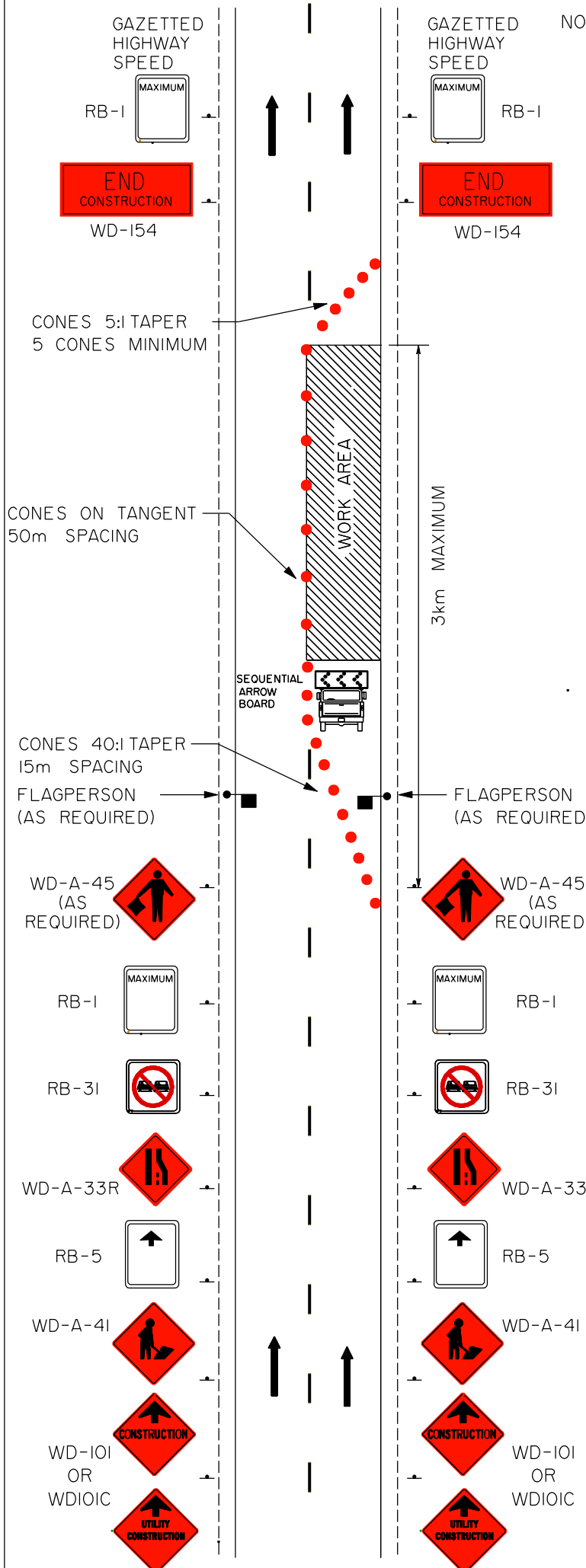

NOTES:

1. Each situation will require individual assessment, and consideration must be given to traffic volume, sight distances, sign spacing, duration of work and other factors to ensure traffic control devices are adequate in each instance.
2. All sign spacing shall be 100m-150m unless otherwise indicated.
3. All signs shall be kept clean and in good condition. The bottom of the sign shall not be less than 0.3m above the road surface.
4. During periods when no work is being actively performed, all non-applicable signs are to be removed or suitably covered.
5. Effective January 1, 2002, the orange portion of all signs, barricades and other traffic control devices shall be fully reflectorized using sheeting which incorporates fluorescent pigment in conformance with Alberta Transportation specifications. Prior to January 01, 2002, any signs not meeting these requirements shall be equipped with red flags for increased visibility.
6. Materials or equipment may only be placed or stored on the outside backslope in a position to reduce damages to vehicles that may run off the roadway.
7. Materials or equipment shall not be stored in the median.
8. The Sequential Arrow Board shall be located in the centre of the closed lane. An additional Sequential Arrow Board is required when traffic volume exceeds 8000 vehicles per day or when sight distance is restricted.

No.	REVISIONS	BY	DATE
Approved:			
Executive Director, Technical Standards Branch			
Date:	MARCH, 2001		
TYPICAL SIGNING UTILITIES CONSTRUCTION ONE LANE CLOSURE FOUR LANE DIVIDED HIGHWAY			
Prepared By: G.E.C.	Checked By: P.H.	Scale: N.T.S.	Dwg No.: TCS-B-5.3B UTILITIES CONSTRUCTION
Graphics File: TCSB5m3b.sgn			

SECTION III
SAMPLE FORMS

SECTION IV
SIGN SCHEDULE
AND
SHEETING REQUIREMENTS

1.0 SIGN SCHEDULE

SIGN NO.	MESSAGE OR DESCRIPTION	SIZE	SHAPE	LETTER HEIGHT AND SERIES NO.	COLOUR	
					MESSAGE	BACKGROUND
IB-2	Alberta Route Marker	45 x 60	Rectangle	Pattern Available	Black	White
IB-8L	Alberta Direction Tab (Left)	45 x 30 60 x 45	Rectangle	Symbol	Black	White
IB-8R	Alberta Direction Tab (Right)	45 x 30 60 x 45	Rectangle	Symbol	Black	White
RA-1	Stop	60 x 60	Octagon	255 mm "C"	White	Red
RB-1	Maximum Speed	60 x 75	Rectangle	#1 - 100 mm "C", #2 - 300 mm Variable	Black	White
RB-5	Maximum Speed Ahead	60 x 75	Rectangle	#1 - 100 mm "C", #2 - 300 mm Variable	Black	White
RB-24	Two-Way Traffic	60 x 75	Rectangle	Symbol	Black	White
RB-31	Do Not Pass	60 x 60	Square	Symbol	Red, Black	White
RD-156	Maximum 50 Passing Workers	60 x 75	Rectangle		Black	White
WA-9	Chevron Alignment	60 x 75	Rectangle		Black	Yellow
WA-31	Divided Highway Begins	90 x 90	Diamond	Symbol	Black	Yellow
WA-31T	Divided Highway Begins Tab	60 x 45	Rectangle	150 mm "C"	Black	Yellow
WA-32	Divided Highway Ends	90 x 90	Diamond	Symbol	Black	Yellow
WB-1	Stop Ahead	75 x 75 120 x 120	Diamond	Symbol	Red, Black	Yellow
WD-101	Construction Ahead	75 x 75 120 x 120	Diamond	#1 - 150 mm "C", 180 mm "C", #2 - 150 mm "C"	Black	Orange
WD-101B	Bridge Construction Ahead	120 x 120	Diamond	#1 - 150 mm "C", 180 mm "C", #2 - 150 mm "C"	Black	Orange
WD-101C	Utility Construction	120 x 120	Diamond		Black	Orange
WD-102	Begin Detour 300 m	90 x 90	Diamond	#1 & #2 - 150 mm "C", #3 - 125 mm "E"	Black	Orange
WD-103	Detour Next __ km	120 x 60	Rectangle	150 mm "C"	Black	Orange
WD-104	Barricade Ahead	90 x 90	Diamond	#1 - 150 mm "C", #2 - 125 mm "C"	Black	Orange
WD-106	One Lane Traffic	75 x 75	Diamond	#1 - 150 mm "C", #2 - 150 mm "C"	Black	Orange
WD-111	Be Prepared To Stop	75 x 75	Diamond	#1, #3, #4 - 100 mm "E", #2 - 100 mm "D"	Black	Orange
WD-116-1L	Barricade (Left)			See Plan TCS-B-4.2	Black	Orange
WD-116-1R	Barricade (Right)			See Plan TCS-B-4.2	Black	Orange
WD-116-2	Road Closed Barricade			See Plan TCS-B-4.2	Black	Orange
WD-116-3	Bridge Out Barricade			See Plan TCS-B-4.2	Black	Orange
WD-116-5	Barricade Arrow			See Plan TCS-B-4.2	White	Black
WD-150	Loose Gravel	75 x 75	Diamond	#1 - 125 mm "D", #2 - 125 mm "D"	Black	Orange
WD-154	End Construction	120 x 60	Rectangle	Pattern Available	Black	Orange

SIGN NO.	MESSAGE OR DESCRIPTION	SIZE	SHAPE	LETTER HEIGHT AND SERIES NO.	COLOUR	
					MESSAGE	BACKGROUND
WD-157	Slow Fresh Oil	75 x 75	Diamond	125 mm "D"	Black	Orange
WD-158	Testing Crew Next 5 km	90 x 90	Square		Black	Orange
WD-169	Loose Chips Please Slow Down	75 x 120	Rectangle	Pattern Available	Black	Orange
WD-170B	Bridge Construction 3 km	120 x 120	Diamond	#1 - 180 mm "C", #2 - 180 mm "E"	Black	Orange
WD-171	Do Not Pass Follow In Convoy	90 x 75	Rectangle	Pattern Available	Black	Orange
WD-172	Follow Pilot Vehicle	75 x 60	Rectangle	Pattern Available	Black	Orange
WD-173	Pilot Vehicle Do Not Pass	165 x 45	Rectangle	Pattern Available	Black	Orange
WD-174	Maximum __ Loose Chips	60 x 120	Rectangle	Pattern Available	Black	White, Orange
WD-179	Traffic Survey Ahead	75 x 75	Diamond		Black	Orange
WD-184	Testing Crew Ahead	90 x 90	Diamond		Black	Orange
WD-187	No Centre Line	75 x 75	Diamond		Black	Orange
WD-188	Ramp Exit	75 x 75	Diamond		Black	Orange
WD-189	Line Painting Ahead	75 x 75	Diamond		Black	Orange
WD-190	Wet Paint	75 x 75	Diamond		Black	Orange
WD-191	Road Grading 3 km	75 x 75	Diamond		Black	Orange
WD-192	Road Construction Next __ km	120 x 90	Rectangle	Pattern Available, 160mm "C"	Black	Orange
WD-193	Grading Next 3 km	120 x 120	Diamond	Symbol	Black	Orange
WD-A-1L	Turn (Left)	75 x 75	Diamond	Symbol	Black	Orange
WD-A-1R	Turn (Right)	75 x 75	Diamond	Symbol	Black	Orange
WD-A-5L	Reverse Curve (Left)	75 x 75	Diamond	Symbol	Black	Orange
WD-A-5R	Reverse Curve (Right)	75 x 75	Diamond	Symbol	Black	Orange
WD-A-7	Advisory Speed	60 x 60	Square	255 mm "E"	Black	Orange
WD-A-22	Bump	75 x 75	Diamond	Symbol	Black	Orange
WD-A-23R	Roadway Narrows (Right)	75 x 75	Diamond	Symbol	Black	Orange
WD-A-23L	Roadway Narrows (Left)	75 x 75	Diamond	Symbol	Black	Orange
WD-A-24	Narrow Structure	75 x 75	Diamond	Symbol	Black	Orange
WD-A-31	Divided Highway Begins	90 x 90	Diamond	Symbol	Black	Orange
WD-A-32	Divided Highway Ends	90 x 90	Diamond	Symbol	Black	Orange
WD-A-33L	Road Narrows - Left Lane Ends	75 x 75	Diamond	Symbol	Black	Orange
WD-A-33R	Road Narrows - Right Lane Ends	75 x 75	Diamond	Symbol	Black	Orange
WD-A-33XL	Road Narrows - Left Lane Ends	75 x 75	Diamond	Symbol	Black	Orange
WD-A-33XR	Road Narrows - Right Lane Ends	75 x 75	Diamond	Symbol	Black	Orange
WD-A-41	Road Work	75 x 75	Diamond	Symbol	Black	Orange
WD-A-43L	Roadside Diversion (Left)	75 x 75	Diamond	Symbol	Black	Orange

SIGN NO.	MESSAGE OR DESCRIPTION	SIZE	SHAPE	LETTER HEIGHT AND SERIES NO.	COLOUR	
					MESSAGE	BACKGROUND
WD-A-43R	Roadside Diversion (Right)	75 x 75	Diamond	Symbol	Black	Orange
WD-A-44	Detour Tab	45 x 30	Rectangle	150 mm "C"	Black	Orange
WD-A-45	Flagperson	75 x 75	Diamond	Symbol	Black	Orange
WD-A-46	Survey Crew Ahead	60 x 60 90 x 90	Diamond	Symbol	Black	Orange
WD-A-48L	Truck Entrance (Left)	75 x 75 90 x 90	Diamond	Symbol	Black	Orange
WD-A-48R	Truck Entrance (Right)	75 x 75 90 x 90	Diamond	Symbol	Black	Orange
WD-A-49	Pavement Drop-off	75 x 75	Diamond	Symbol	Black	Orange
WD-A-51L	Roadside Diversion (Left) (Two Lanes)	75 x 75	Diamond	Symbol	Black	Orange
WD-A-51R	Roadside Diversion (Right) (Two Lanes)	75 x 75	Diamond	Symbol	Black	Orange
WD-A-100	Sharp Shoulders	75 x 75	Diamond	150 mm "C"	Black	Orange
WD-A-105R	Hazard Marker - Keep Right	30 x 90	Rectangle		Black	Yellow
WD-A-111	Grooved Pavement	75 x 75	Diamond	Symbol	Black	Orange
WD-A-111T	Grooved Pavement Tab	60 x 30	Rectangle	150 mm "C"	Black	Orange
WD-A-120	Slow Moving Vehicle	51 x 51 x 51	Triangle	Symbol	-	Orange
WD-B-3	Two-Way Traffic Ahead	75 x 75	Diamond	Symbol	Black	Orange
WD-B-4	Traffic Signals Ahead	90 x 90 120 x 120	Diamond	Symbol	Red, Yellow, Green, Black	Orange
WD-B-4T	Structure Width Tab (___ m)	60 x 30	Rectangle		Black	Orange
WD-T	Distance Tab (___ km)	60 x 30	Rectangle		Black	Orange

NOTES:

1. Sign size, shape, symbol and color are to be in accordance with the latest edition of the Uniform Traffic Control Devices for Canada Manual and applicable Alberta Transportation standards. Where there is any discrepancy between the UTCD Manual and the AI standards, the latter shall prevail.
2. The #1, #2, #3, and #4 refer to line 1 through line 4 of text on a sign.
3. For the sign WD101, 120 x 120 is used on the main alignment and 75 x 75 is used on intersecting roads.

2.0 SIGN SHEETING REQUIREMENTS

The orange portion of all signs, barricades and other Traffic Control Devices shall be fully reflectorized using High Brightness, Retroreflective, Non-Metalized, Prismatic Sheeting Material which incorporates durable, transparent, fluorescent pigment and meets the following requirements:

BRIGHTNESS REQUIREMENTS (90° Rotation Angle)		
Observation Angle	Entrance Angle	Orange
0.2	-4	200
0.2	30	92
0.5	-4	80
0.5	30	50
A Minimum Coefficient of Retroreflection (RA) cd/ft ² (cd . lx ⁻¹ . m ²)		

All other colours of sheeting material shall be Type III, High Intensity retroreflective sheeting meeting the requirements of ASTM D4956.