

# Hydrocarbon Upgrading Demonstration Program (HUDP)- Update

HUTF Meeting  
Calgary, Alberta

*Duke du Plessis*  
*Alberta Energy Research Institute*  
*Alberta Employment, Immigration and Industry*

5 March, 2007

# (HUDP)- Background

- In early 2005 Hydrocarbon Upgrading Task Force Workshops identified critical needs for a sustainable energy future:
  - next generation upgrading technologies
  - skilled personnel
- Requires the combined effort and investments of both the public and private sectors to share the risk and focus on the key technologies and environmental challenges
- Industry-Government Working Group developed the vision and a phased implementation plan for establishing a Hydrocarbon Upgrading Program (HUDP) with a strong training component
  - Modeled after Underground Test Facility (UTF) in 1980's
  - *Government's investment through AOSTRA was key to timely commercialization of SAGD technology and training skilled personnel*

# HUDP Vision and Goals

## *Vision*

Alberta is a world leader in demonstrating and commercializing radically new integrated technologies that:

- maximize the value of carbon and bitumen as abundant and competitive sources of ultra-clean fuels, specialized chemicals, petrochemicals, and power
- minimize environmental impacts
- Provide hands-on training for skilled industrial personnel

## *Goals*

- Accelerate the pace of the development, demonstration and commercial deployment of next generation upgrading technologies.
- Build capacity in Alberta for the timely adaptation, development and demonstration of the relevant upgrading and environmental technologies to achieve Alberta's Hydrocarbon Vision.

# HUDP Phase 1 Study

- Participants: AERI + 7 companies
  - Signed multiparty agreement
  - Engaged engineering company
  - Provided project direction and oversight through Steering Group and Technical Committee
- Evaluated 19 technology configurations producing refined products and petrochemical feedstocks against a conventional 200,000 bpd reference plant
- 25 licensors and developers contacted
- About 100 processes screened
- Identified 5 technologies with best potential
- Completed Fall 2006

# HUDP Phase 1- Representative Process Schemes and Products

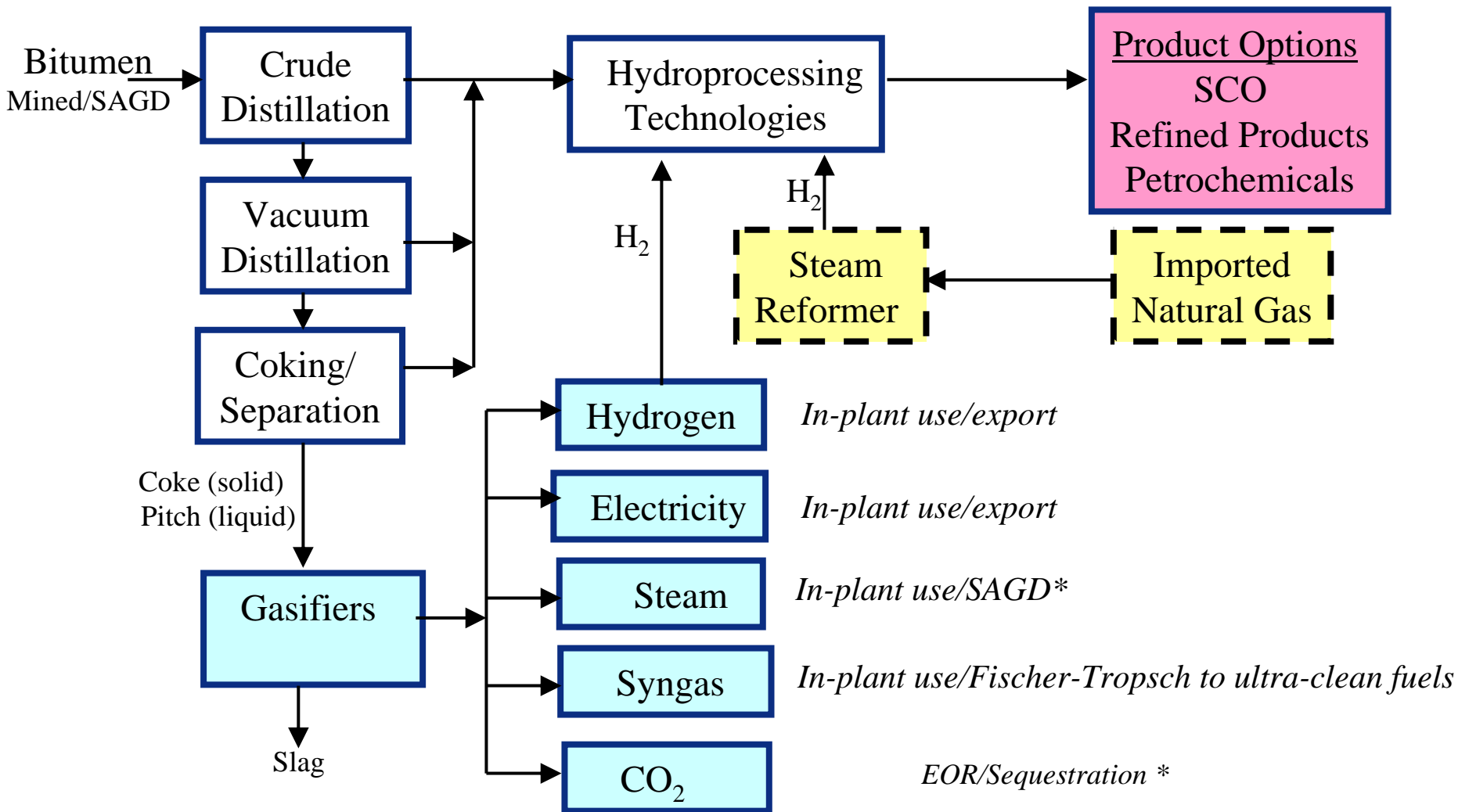

\* not included in Phase 1 of AERI/Industry study

# Representative Process Schemes & Products for 200,000 bpd Bitumen Feed

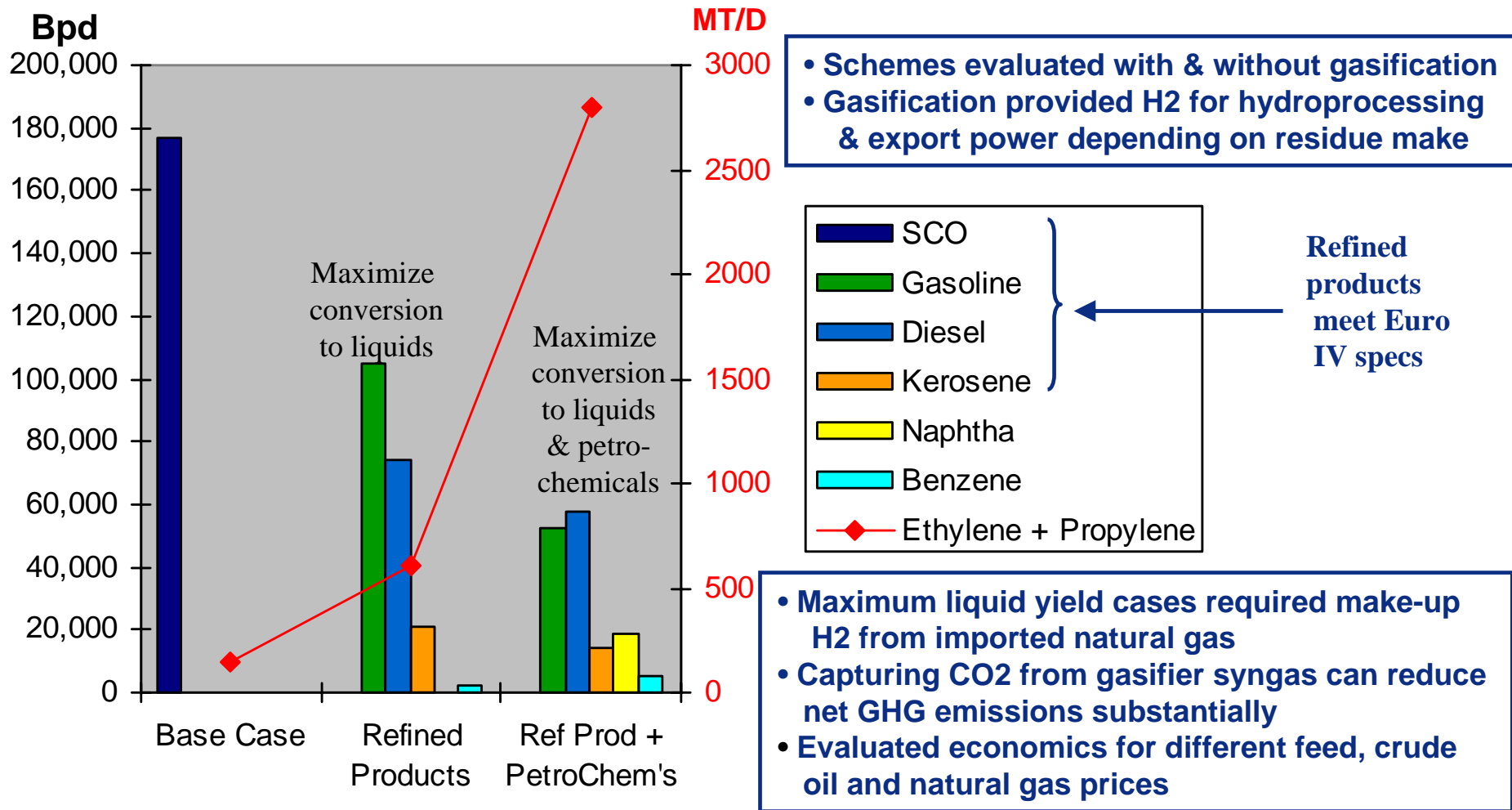

# HUDP Phase 1 Technology Bull's Eye Diagram

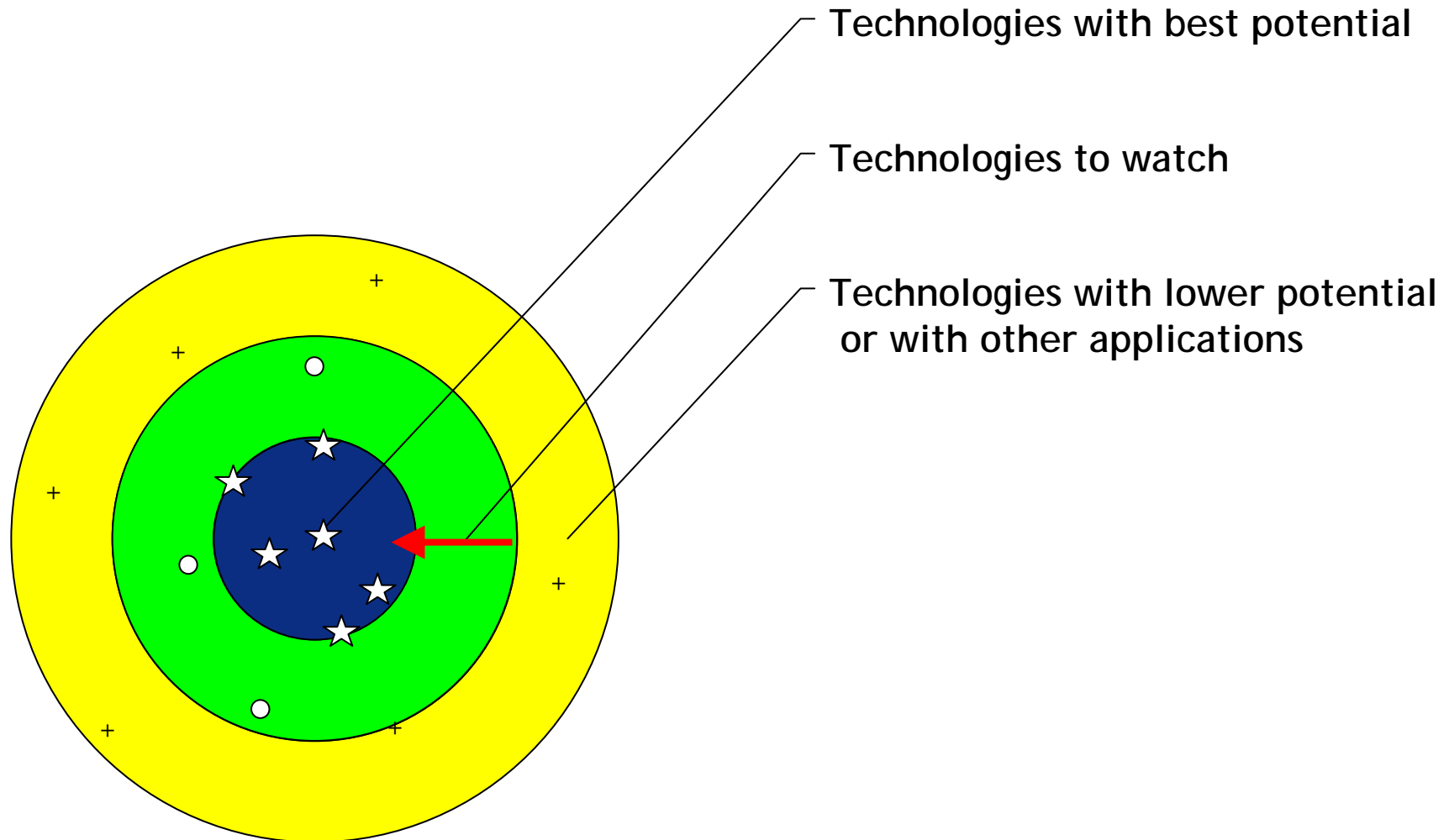

# HUDP Phase 1

## General Conclusions

- Upgrading bitumen beyond SCO to high quality transportation fuels and petrochemicals adds value and improves economics
- Minimizing residues and capital investment, while maximizing liquid product yields, provides the best economics
- Gasifying residual bottoms (coke, pitch) to provide hydrogen, fuel gas, steam and power is economically attractive especially at higher gas prices
- Gasifying liquid residues (pitch) results in appreciable cost savings vs. solid petroleum coke fed gasification
- Gasification well suited to capturing CO<sub>2</sub> for EOR or sequestration



# HUDP Phase 2

- New initiative announced by Alberta Energy and AERI at CEO Breakfast, Nov 16, 2006
- Issued prospectus and request for expressions of interest
- Government prepared to invest \$100 mill over 5 years and is looking for similar investments from industry
- Goal: Develop and demonstrate next generation “clean” carbon/coal and hydrocarbon upgrading technologies

# HUDP Phase 2 – Current State

- Received 23 expressions of interest from 18 companies - Feb 2, 2007.
- Selected 9 technologies for submission of full proposals by end April, 2007
  - 3 non-catalytic/thermal
  - 2 catalytic hydroprocessing
  - 2 gasification
  - 2 CO2 capture
- Technologies at different stages of development & will be stage-gated
- Anticipate funding decisions by June 2007

# Business Guiding Principles

- Cost sharing: A government/industry cost sharing formula will be developed for each project
- Stage-gating to manage risk
- Ownership: Plant and facilities owned and operated by the private sector participants.
  - After meeting projects goals facility made available to other users, and for training purposes at commercial terms
- Intellectual property
  - Background IP remains with original owner of the IP.
  - IP developed as part of co-funded activities is owned by the private sector participants with an obligation to commercialize the technology in Alberta within 5 years<sup>(1)</sup>
  - If not commercialized after 5 years<sup>(1)</sup> the technology made available to other Alberta users under normal commercial licensing terms

<sup>(1)</sup> term negotiated by parties

# Conclusion

- Research and innovation are central to achieving Alberta's sustainable energy goals and fundamental to Alberta's continued prosperity.
- We must begin now to transform our energy system to improve the efficiency with which we can produce and convert more of our resources to value-added products and minimize emissions including CO<sub>2</sub>.
- No one group can do it alone
- Requires the combined effort and investments of both the public and private sectors to share the risk and focus on the key technologies and environmental challenges
- HUTF & HUDP are opportunities for collaborative action

# Contact Information

*Eddy Isaacs, Executive Director,  
Alberta Energy Research Institute  
Suite 2540, 801 – 6 Avenue SW,  
Calgary, AB T2P 3W2  
[eddy.isaacs@gov.ab.ca](mailto:eddy.isaacs@gov.ab.ca)  
Tel. (403)297-5219*

*Duke du Plessis, Senior Advisor and Research Manager  
Alberta Energy Research Institute  
Suite 2540, 801 – 6 Avenue SW,  
Calgary, AB T2P 3W2  
[duke.duplessis@gov.ab.ca](mailto:duke.duplessis@gov.ab.ca)  
Tel. (403)297-3635*