

**ALBERTA BITUMEN PROCESSING INTEGRATION  
STUDY**

**Final Report**

**By**

**David Netzer, Consulting Chemical Engineer**

**And**

**Associates**

**For**

**The Province of Alberta  
Economic Development Department  
Investment and Industrial Development Branch**

**Department of Energy**

**The Alberta Energy Research Institute**

**And Industry Sponsors**

**March 2006**

## Table of Contents

<b>1.0.</b>	<b>EXECUTIVE SUMMARY .....</b>	<b>1</b>
<b>2.0.</b>	<b>BACKGROUND .....</b>	<b>8</b>
<b>3.0</b>	<b>PROCESS SELECTION RATIONALE .....</b>	<b>10</b>
3.0.1	Study strategy .....	10
3.0.2	Simplified process sequence.....	15
3.1	Process Scheme Rationale .....	17
3.1.1	Atmospheric and vacuum distillation .....	17
3.1.2	Delayed coking versus deasphalting.....	17
3.1.3	Olefin production.....	18
3.1.4	Advantageous steam cracking feeds .....	18
3.1.5	Conventional steam cracking versus Deep Catalytic Cracking.....	20
3.1.6	Butadiene production.....	21
3.1.7	Catalytic reforming option.....	22
3.1.8	Gasification of coke.....	22
3.1.9	Oxygen, nitrogen and argon production .....	22
3.1.10	Shift of carbon monoxide to hydrogen .....	23
3.1.11	Acid gas removal .....	23
3.1.12	Hydrogen purification and fuel gas .....	23
3.1.13	Sulphur recovery and tail gas treating .....	24
3.1.14	Alkylation system .....	24
<b>3.2.</b>	<b>Utility Rationale.....</b>	<b>25</b>
3.2.1	Steam turbine versus electric motor drive .....	25
3.2.2	Redundant capacity in power generation.....	27
3.2.3	Air cooling versus water cooling.....	27
<b>4.0.</b>	<b>PROCESS DESCRIPTION .....</b>	<b>28</b>
<b>4.1.</b>	<b>Conversion Section .....</b>	<b>28</b>
4.1.1	Crude (Distillate recovery) and vacuum units .....	28
4.1.2	Delayed coking .....	31
4.1.3	Hydrocracking .....	33
4.1.4	Fluid catalytic cracking feed pretreatment.....	38
4.1.5	Fluid catalytic cracking (FCC) .....	40
4.1.6	Catalytic reforming .....	43
4.1.7	Alkylation .....	47
4.1.8	Diesel hydrotreating.....	50
4.1.9	Amine system sour water stripping .....	52
4.1.10	Low grade ammonia recovery .....	52
4.1.11	Sulphur recovery.....	54
4.1.12	Ammonia scrubbing, oxidation to ammonium sulfate.....	56

<b>4.2. Air Separation Industrial Gases Production</b>	<b>57</b>
4.2.1 Air separation unit(ASU).....	57
<b>4.3. Gasification – Hydrogen and Synthesis Gas Production .....</b>	<b>58</b>
4.3.1 Delayed coke gasification.....	58
4.3.2 Shift reaction and gas cooling.....	61
4.3.3 Rectisol acid gas removal, Nitrogen Wash, PSA hydrogen purification.....	62
4.3.4 Ammonia service/Nitrogen Wash.....	64
4.3.5 PSA hydrogen purification .....	65
<b>4.4. Olefins Production .....</b>	<b>66</b>
4.4.1 Steam cracking.....	66
Cracking.....	67
Cracked Gas Compression.....	68
Cold Fractionation (Ethylene Recovery).....	69
Warm Fractionation (Propylene -C <sub>4</sub> Recovery).....	69
4.4.2 Butadiene extraction .....	70
<b>4.5. Offsites Definition .....</b>	<b>73</b>
4.5.1 Steam and Power generation.....	74
4.5.2 Flue gas treating.....	77
4.5.3 Cooling water system.....	78
4.5.4 Tempered water system .....	78
4.5.5 Electric power distribution.....	78
4.5.6 Plant air .....	79
4.5.7 Tankage.....	79
4.5.8 Fuel oil/fuel gas system .....	80
4.5.9 Gasoline blending .....	81
4.5.10 Major fuel consumers .....	81
<b>5.0. CAPITAL COST ESTIMATE .....</b>	<b>82</b>
5.0.1 Inside battery limits (ISBL).....	82
5.0.2 Outside battery limit (OSBL) .....	83
5.0.3 Off plot.....	84
5.0.4 Contractor charges .....	84
5.0.5 Other project costs .....	85
5.0.6 Owner’s costs.....	85
5.0.7 Working capital components .....	86
<b>5.1. Method of Cost Estimate.....</b>	<b>86</b>
5.1.1 Cost of ISBL .....	86
5.1.2 Cost of offsites (OSBL).....	87

5.2. Canadian Construction Adjustment .....	88
5.3. Capital Cost Breakdown .....	89
5.3.1 Conversion section.....	90
5.3.2 Coke gasification - Hydrogen/ammonia synthesis gas.....	90
5.3.3 Steam cracker - 1,000 KT/Y mixed feeds.....	91
5.3.4 Offsite items.....	91
5.3.5 License fees and royalties.....	93
5.3.6 Working Capital.....	93
5.3.7 Project Contingency.....	93
5.3.8 Project Expenditure Curve.....	93
5.3.9 Total Project Cost .....	94
<b>6.0. ECONOMIC ANALYSIS .....</b>	<b>95</b>
6.1. Economic Analysis Assumptions .....	95
6.2. Economic Model.....	98
6.3. Economic Analysis Results .....	98
<b>7.0. RECOMMENDATIONS FOR FUTURE STUDIES .....</b>	<b>100</b>
7.1. Phased Construction .....	100
7.2. Marketing Logistics and Terminals .....	100
7.3. Plot Plan and Site Selection.....	101
7.4. Onsite Ammonia Production .....	101
7.5. Other Ammonia Options.....	101
7.6. Olefin Plant Configuration.....	102
7.7. Butadiene Recovery.....	102
7.8. Electric Power Issues .....	102
7.9. Vacuum Distillation.....	102
<b>A.0. APPENDICES .....</b>	<b>103</b>
<b>A.1. Integration Study Industry Sponsor Companies .....</b>	<b>103</b>
<b>A.2. Site and Climate Data.....</b>	<b>104</b>
<b>A.3. Terms of Reference.....</b>	<b>108</b>
<b>A.4. Bitumen Properties .....</b>	<b>113</b>

**A.5. Process Design Drawings.....114**

Figure AB-001 Executive Summary  
Figure AB-002 Bitumen Processing Integration Study Plant Overview, Sheets 1 and 2  
Figure AB-003 Crude Distillation – Diluent and Diesel Recovery  
Figure AB-004 Vacuum Distillation  
Figure AB-005 Delayed Coking  
Figure AB-006 Light Vacuum Gas Oil Hydrocracking  
Figure AB-007 FCC Feed Hydrotreater  
Figure AB-008 Fluid Catalytic Cracking Unit – Converter Section, Sheet 1  
Figure AB-009 Fluid Catalytic Cracking Unit – Converter Section, Sheet 2  
Figure AB-010 Fluid Catalytic Cracking Unit – Main Fractionator  
Figure AB-011 Fluid Catalytic Cracking Unit – Main Fractionator Overhead  
Figure AB-012 Fluid Catalytic Cracking Unit – Absorber/Stripper & Debutanizer  
Figure AB-013 Fluid Catalytic Cracking Unit – Sponge Absorber  
Figure AB-014 Fluid Catalytic Cracking Unit – Amine Treating  
Figure AB-015 Fluid Catalytic Cracking Unit – C<sub>3</sub>/C<sub>4</sub> Splitter  
Figure AB-016 Catalytic Reforming  
Figure AB-017 Alkylene™ Solid Acid Alkylation  
Figure AB-018 Aromatic Saturation of Diesel via Two-Stage Hydrotreating  
Figure AB-019 Sulphur Recovery  
Figure AB-020 Delayed Coke Gasification  
Figure AB-021 Shift and Gas Cooling  
Figure AB-022 Rectisol Process  
Figure AB-023 Steam Cracking Ethylene Plant – Cracking Section  
Figure AB-024 Steam Cracking Ethylene Plant – Compression/Products Fractionation  
Figure AB-025 Butadiene Extraction and Recovery  
Figure AB-026 C<sub>4</sub> Raffinate Separation  
Figure AB-027 Steam and Power Generation  
Figure AB-028 TBP of Bitumen

**A.6. Economic Model Price Assumptions.....143**

**A.7. Colt Engineering Due Diligence Report.....145**

## 1.0. EXECUTIVE SUMMMARY

### Background

The growing demand for refined petroleum products in North America has resulted in constrained refinery capacity and increasing product prices. While refinery capacity expansions are being planned, the demand for refined products is expected to continue to exceed available domestic supply. Of the North American market, the United States is the largest consumer of energy products. Higher demand in that marketplace will result in the need to increase reliance on foreign imports from politically unstable regions, creating concern over the security of supplies.

However, secure supply is available closer to home. Alberta represents one of the safest and largest sources of crude oil in the world. The vast resource of the Alberta oil sands represents a viable opportunity to support product demand growth and reduce foreign dependency for the North American market.

The Government of Alberta has a vision for its hydrocarbon upgrading industry: “*Alberta will achieve a competitive hydrocarbon upgrading industry through refining and petrochemical plants that expand the market for Alberta’s bitumen resource and produces higher value products in Alberta.*” The vision for hydrocarbon upgrading is a key component in the development of an integrated energy strategy that looks beyond extraction to ensure both the highest value and best use of our resources for the benefit of all Albertans.

The Government of Alberta in collaboration with industry partners has undertaken a number of technical and marketing studies that explore value-added upgrading of oil sands bitumen to finished products. These studies have been under the mandate of the Hydrocarbon Upgrading Task Force (HUTF), a joint government and industry initiative to develop business cases and promote opportunities for new refining and petrochemical investment in Alberta. The HUTF was established in February 2004.

The returns to Alberta and Canada from a fully integrated system could be significant. Successful upgrading to finished products could add billions of dollars to the Alberta and Canadian economy and broaden Alberta’s markets for value-added products, ultimately helping Alberta companies to increase their global competitiveness.

As well as the value-added consideration, the high level of activity in the oil sands has raised a concern among industry stakeholders. With the large number of project proposals to develop the oil sands within the next 10 to 15 years, production of the bitumen and synthetic crude oil from the oil sands may exceed current refinery capacity resulting in the value of these products declining over time. Increasing Alberta’s capacity to produce finished products would mitigate this potential problem and serve the North American market better. In addition, the lower cost bitumen derived feedstocks would help sustain Alberta’s world-class petrochemical industry, which is currently based on higher-priced natural gas feedstocks.

## **Highlights of Study**

The Government of Alberta and industry partners retained David Netzer, Consulting Chemical Engineer of Houston, and his group of associates (the consultant) to develop a conceptual design for an integrated bitumen upgrading, refining and petrochemical complex in Alberta.

The study was designed to build on previous integration studies and goes one step further with the development of a technical design for a conceptual upgrading, refining and petrochemical complex based on technologies in use today. The main objective of the study was achieved: an integrated complex transforming bitumen into a variety of high value products is technically feasible. In addition, an integrated complex could have significant potential economic and environmental advantages over non-integrated facilities through the benefits of synergies created from the sharing of feedstocks and infrastructure needs.

Ultimately, this conceptual study represents only one possible configuration for a potential integrated plant sited in an Alberta location. To develop such a conceptual study further, additional detail would be required to reduce the technical and economic risks. For example, extensive engineering studies would be needed to further develop the design and cost estimates. In supporting this study, the government is attempting to facilitate more detailed evaluations by prospective investors with the goal of increasing the value-added opportunities in Alberta, rather than suggesting a design basis for constructing such a plant. It is expected that interested parties will perform their own assessments utilizing their own assumptions regarding the viability of the integrated complex.

The potential benefits of an integrated complex are:

- Significant savings in capital and operating costs based on synergies among the different processing steps,
- Significant reduction in environmental footprint including management of emissions and waste streams,
- Improved overall economics based on transforming low-cost bitumen into a variety of higher valued products.

## **Conceptual Design**

The guidelines for the conceptual plant design were to utilize current technologies, produce high quality refined products to meet market specifications, provide petrochemical feedstocks, and to comply with regulatory requirements.

No market development studies were undertaken in conjunction with this study. Assumptions for product demand relied on previous market studies by Purvin & Gertz, Inc. (PGI) for the HUTF that identified the United States and East Asia as potential markets for finished gasoline, kerosene and diesel products from Alberta. It was assumed that primary petrochemicals and fertilizer precursors, such as ethylene, propylene and ammonia syngas would be mainly sold to Alberta facilities for further value-added manufacturing to various

derivative products. Therefore, proponents would require a major market development program before committing to such a project.

The plant location for this integrated complex is notionally in the greater Edmonton area where labour, support services and other infrastructure are assumed to be more available. This assumption is significant since today's labour market in Alberta is facing shortages of skilled labour that creates pressure on project costs. The Alberta government and industry are working together to meet this challenge and provide options for companies to increase labour availability.

The basis of the conceptual plant design is a process scheme developed during the study proposal's preparation stage and submitted to the government and industry sponsors in September 2005. The plant's process flow was subsequently developed by the consultant's ongoing studies and the input of a Steering Committee consisting of industry sponsors and government representatives. Colt Engineering (Colt) was selected by the Study Steering Committee to provide an independent due diligence review of the technical design proposal. Colt endorsed the technical validity, plant yields and operability, and cost estimating methodology of the study.

To take advantage of integration and economies of scale, plant capacity was set at 300,000 barrels per stream day (bpsd) of undiluted bitumen. The conversion processes were selected to obtain the most valuable product slate from bitumen feedstock while minimizing capital costs. The major processes are:

- Atmospheric and vacuum distillation
- Delayed coking
- Hydrocracking
- Catalytic cracking
- Reforming and alkylation for gasoline
- Diesel hydrotreating
- Steam cracking to produce olefins.

The result is a slate of fuel products (diesel, kerosene and gasoline), petrochemical products (ethylene, propylene, butadiene and pyrolysis gasoline) and synthesis gas for ammonia. A simplified flow plan is shown below.

The output results in about 62.4 weight (wt)% of the bitumen feed converted to fuel products, 11.3 wt% to petrochemicals and 4.7 wt% to elemental sulphur. Of the balance, 17.5 wt% is petroleum coke, mostly carbon that is partially oxidized to supply hydrogen for the hydrocracker, diesel hydrotreating and ammonia synthesis gas. The total energy for the conversion, including 3% for the steam cracker, plus the power generation, is about 12% of the energy value of the bitumen. The sources of the energy consumed in the plant are internally generated fuel gas, rejected carbon, and low sulphur fuel oil, with the remainder supplied by importing low cost coal, fuel oil and petroleum coke. The essential feature of the plant design is to be as self-sufficient as possible by utilizing low or zero value materials such as coke for hydrogen manufacture, imported coal for plant fuel; and to convert low



value process unit off gases and heavy liquids to high value petrochemical products in the steam cracker.

The large on-site combined power generation and steam plant utilizes fluidized bed boilers that have the flexibility to burn available petroleum coke, as well as waste unconverted coke from the partial oxidation process in the hydrogen plant. The balance of the energy is low cost purchased coal and fuel oil. The economic utilization of low or negative value materials also has the advantage of permitting the major process units to operate at lower conversion rates (for example the hydrocracking and gasification), and be of smaller size by reducing or eliminating recycle operations. This integration decreases both capital and operating costs.

### **Feedstocks**

The feedstocks supplied to the complex are the following:

1. Net feed of 300,000 bpsd of 8.5 API bitumen,
2. 100,000 bpsd of bitumen diluent, estimated 52 API, recycled to the mining area,
3. About 6,230 bpsd iso-butane, 2351 bpsd propane, and 4366 bpsd ethane,
4. About 2,000 metric tonnes per day (mtpd) sub-bituminous coal of 8,600 Btu/lb Higher Heating Value (HHV) heat content,
5. About 900 mtpd of petroleum coke from outside the boundary limit (OSBL),
6. An additional 2,300 mtpd of coal is required for the export power sensitivity case,
7. About 700 bpsd of low grade (high sulphur) fuel oil, and
8. About 3,700 metric tonnes per hour (mtph) of river water. An additional 450 mtph (13%) is needed for the export power case.

### **Power Generation**

The rotating equipment in the facility is driven exclusively by electric motors. This feature eliminates the cost of a winterized network of condensate distribution lines. The facility is totally self-sufficient in electric power generating a nominal 540 megawatts (MW) (gross) with three 50% capacity trains to provide one train redundancy, and connection into the local electric grid for emergency service or the export of surplus power on a spot basis. About 40% of the power is attributed to excess steam generated in the complex.

The complex comprises seven major facilities including the required storage to maintain operations:

1. Upgrader refining section,
2. Air separation units (ASU),
3. Hydrogen synthesis gas via gasification of delayed coke,
4. Olefin plant via steam cracking of multiple streams,
5. Butadiene extraction,
6. Electric power generation via coal/coke fired boilers and
7. Tank farm for feeds, products and intermediate products.

## Plant Yields

Plant output for all products assumes bitumen input at 300,000 bpsd for 350 days of the calendar year. The following fuel products volumes are produced for market sale:

- 1 A single grade mixed diesel product
  - 118,570 bpsd (655 tph)
  - 38 API with sulphur content of 5 parts per million (ppm)
  - 48 Cetane Index,
- 2 A single grade reformulated gasoline mixed product
  - 98,525 bpsd (489 tph)
  - 56 API - 93 Research Octane Number (RON), 85 Motor Octane Number (MON)
- 3 A single grade kerosene (Jet Fuel A)
  - 20,750 bpsd (111 tph)
  - 42 API, 140°F flash point, 24 mm smoke point
- 4 Hydrogen
  - 128 million standard cubic feet per day (MM scfd) (12.8 tph) of 99.9 vol% at 800 pounds per square in gauge (psig).

The following petrochemical products are produced:

1. Ethylene, polymer grade: 1,000 kilo tonnes per year (KT/Y) nominal production,
2. Propylene, polymer grade: 553 KT/Y nominal production,
3. Butadiene, market grade: 95 KT/Y nominal production,
4. Hydrotreated pyrolysis gasoline of 72 wt% benzene (and the balance consisting of toluene, xylene and some hexane): 263 KT/Y.

The following fertilizer products are produced:

1. Ammonia synthesis gas: nominal 3,000 metric tpd (mtpd), 3.0 H<sub>2</sub>/N<sub>2</sub>, at 800 psig,
2. Ammonium sulfate, ungranulated: 40 wt% aqueous solution nominal 550 mtpd,
3. Elemental sulphur: nominal 2,260 mtpd, and
4. Ash: about 250 mtpd.

# Integrated Bitumen Processing Plant – Simplified Flow Plan

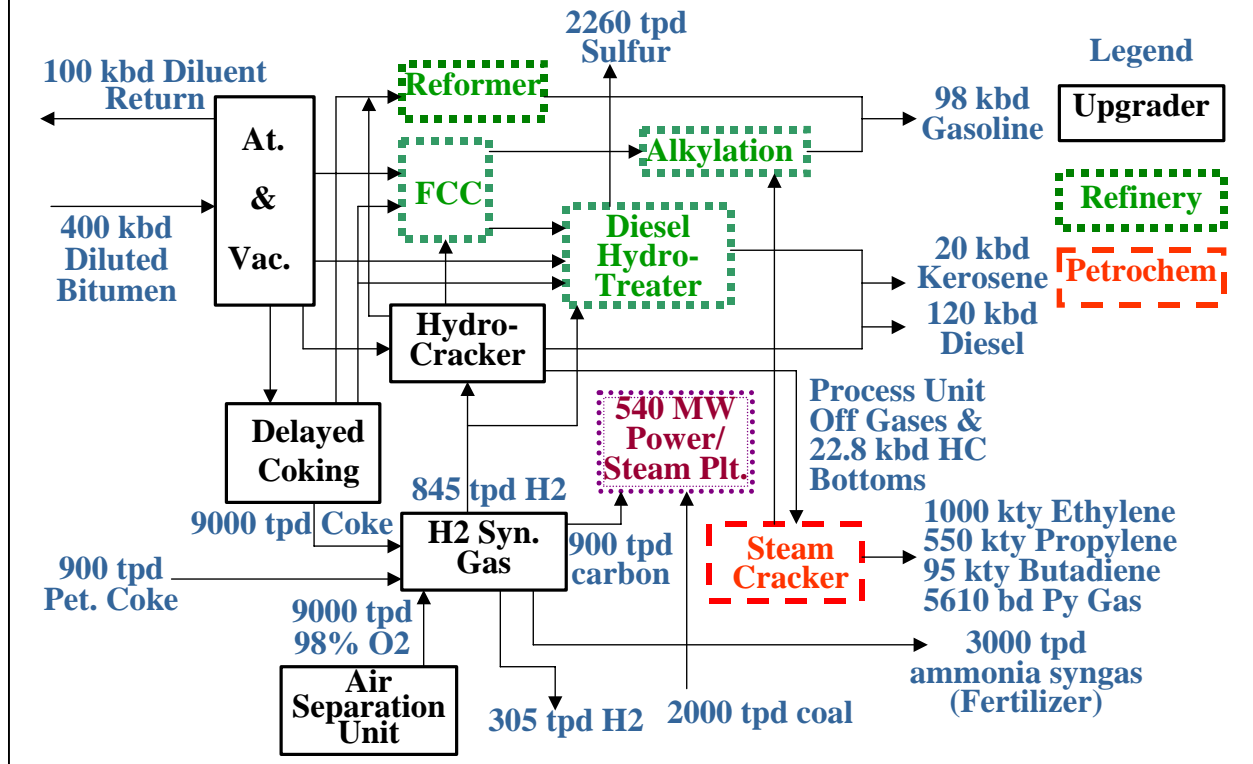

## Capital Investment

The estimated capital investment in as spent dollars at the Edmonton area location is just under US \$10 Billion, including 5% compounded capital escalation during project implementation over the period from 2007 to 2012. This cost estimate contains 40% contingency allowance in accordance with the widely used criteria of the Association for Advancement of Cost Engineering (AACE). Under these criteria, a conceptual project at this state of development was somewhat above a Class V category estimate but short of a Class IV. Consistent with the conservative approach in the study, the cost estimate was designated a Class V to which a 40% contingency applied.

It is recognized that several recent oil sands projects in Alberta have cost overrun estimates. The quality category of the original estimates for these other projects has not been publicized. Various factors are cited for these overruns, including shortage of skilled labour and materials. For purposes of this study, a stable economic climate and availability of the required materials and labour force is assumed. The study's capital cost estimates assumes a 12% location factor between the United States Gulf Coast (USGC) and the Edmonton area.

## **Project Economic Analysis**

The major components of the project economic analysis consist of the various cost estimates: capital, operating, and applicable escalation rates and contingency allowance, as discussed above. There are also assumptions for the input bitumen price, and the market values for the plant output. The bitumen and fuel products were valued based on historical ratios to the crude oil price forecast from an earlier PGI study. Similarly, the petrochemical output values were based on historical relationships to the natural gas price forecast. Both the natural gas price and the West Texas Intermediate crude oil price forecasts used in the economic model are from a published source, GLJ Petroleum Consultants Ltd. and are summarized below:

	<b>2006</b>	<b>2007</b>	<b>2008</b>	<b>2009</b>	<b>2010</b>	<b>2015</b>	<b>2020</b>
Crude Oil – West Texas Intermediate - US\$/bbl	57.00	55.00	51.00	48.00	46.50	47.75	52.77
Natural Gas – Alberta Plant Gate - C\$/MMBtu	10.35	9.00	7.75	7.25	6.95	7.15	7.90

The Internal Rate of Return (IRR) over 24 years was calculated by the discounted cash flow method for the reference case results and several sensitivities. The transportation cost sensitivities are based on \$2 per barrel in the reference case, and the Edmonton location factor in the reference case is 12%. The reference case product value to crude ratios is taken from the PGI market studies mentioned above while actual 2004 – 2005 average values were used for a sensitivity case. The case results are shown below:

- Reference Case: GLJ WTI crude price forecast 19.5% IRR
- + \$10/barrel in the crude price forecast 23.0% IRR
- - \$10/barrel in the crude price forecast 15.6% IRR
- + 10% in capital cost 18.1% IRR
- - 10% in capital cost 21.0% IRR
- \$3/barrel product transportation cost 19.1% IRR
- \$4/barrel product transportation cost 18.6% IRR
- Edmonton location factor of 25% 18.0% IRR
- 2004-2005 Average product to crude value ratios 19.9% IRR

The return on investment calculations must be treated as hypothetical at this stage of project development, as they are based on a conceptual process sequence, and derived from many assumptions about conditions in a future timeframe. To go beyond the conceptual stage of this project, as noted above, would require a detailed engineering design study to raise the cost estimate quality from the Class V level to Class III, and a decision to proceed. The purpose of the conceptual study was to stimulate interest in pursuing further studies, rather than to provide a design for building such a plant.

## 2.0. BACKGROUND

Mr. David Netzer, PE, Consulting Chemical Engineer, of Houston and his team of consultants from the United States and Canada ([www.petrochemicals.dnetzer.net](http://www.petrochemicals.dnetzer.net)) were selected by the province of Alberta and the industry sponsors to perform the study as outlined in the terms of reference (Appendix A.3.). The ultimate responsibility for the execution of the study rests with David Netzer. John Lehman of JHL chemical Process Engineering Services in Edmonton is a key member of the core team. Dr. Richard Nielsen of Houston edited the report. Colt Engineering of Calgary was selected by the Province and the Steering Committee to provide advice and a due diligence review of the study.

The feed for the project is bitumen, 8.5 API (1.011 specific gravity), produced in the Fort McMurray area and pipelined to Alberta's Industrial Heartland area for a new grass roots integrated processing facility. One of the key attributes in the study is that the lower value residual materials obtained from the upgrading and refining operations include advantageous feeds for olefins production via steam cracking. Further value-added is achieved by integrating synthesis gas generation from very low value petroleum coke for an existing or future ammonia production facility and for internal hydrogen consumption.

It was judged by our team that bitumen capacity of 300,000 bpsd of undiluted bitumen would permit world-scale size for all major downstream processing refinery and petrochemical units in the project while holding the capital investment, financial exposure and marketing risks at manageable levels. That is, a 300,000 bpsd upgrader/refinery produces a sufficient amount of low value by-product to feed a world-scale ethylene production facility. The overall integrated facility will be self-sufficient in electric power, hydrogen and steam. Steam will be produced by combustion of unconverted carbon from gasification, supplemented by local coal supplies as required. The facility will be equipped with all necessary environmental safeguards to meet existing and anticipated future environmental regulations.

Although low API crude has been processed in Venezuela, to the best of our knowledge, no one has ever built a refinery consuming 8.5 API bitumen on an exclusive feedstock basis, much less in an integrated refinery-petrochemical production complex. Therefore the overall design concepts had to be evaluated without prior industrial reference in terms of the overall integration of process units. One attribute of this feedstock situation is an optimized product slate that features a high ratio of diesel fuel to gasoline. This "peculiar" product slate was brought to the attention of sponsors and the Steering Committee. It is recognized that the diesel to gasoline market ratio in North America is considerably lower; however, the relative global demand for diesel is increasing.

For instance, proposed GTL (gas to liquid) projects are geared toward high diesel production, 50-75% of their total product slate. A significant capital investment was allocated to bring the quality of the produced diesel in line with the diesel quality expected from future GTL plants. All associated marketing issues and market development programs are outside the scope of this study. For the project economic assessment, it is assumed that the fuel products are exported in product pipelines to the U.S. Midwest, which previous Purvin & Gertz (PGI) studies identified as one potential market for Alberta refined products.

The captive and exclusive feedstock feature brings up some issues related to diluent, feed storage, product storage, infrastructure and on-site storage as discussed in the body of the report. The upgrader and the steam cracker would have the capability to operate totally independent of each other but in an unoptimized mode of operation.

About 88% of the hydrogen for upgrading and refining processing, export hydrogen and ammonia synthesis gas is produced by reacting delayed coke (about 18 wt% of the bitumen feed) with water vapor using partial oxidation (gasification) and water shift reactions. The remainder of the plant hydrogen supply comes from the steam cracker and the gasoline reformer units. Ultimately, hydrogen, CO<sub>2</sub> and sulfur are produced and this partial oxidation reaction rejects 300 tph of carbon, about 17.5% of the total carbon in the bitumen. The FCC unit while producing gasoline rejects an additional 1.5 wt % of carbon in the bitumen. The carbon, sulfur and nitrogen rejections would increase the hydrogen content from 9.9 wt% in the bitumen feed to over 13 wt% in the upgraded fuel and olefins products and this 30wt% increase in hydrogen content of the products is the essence of the upgrading.

### **3.0. PROCESS SELECTION RATIONALE**

A preliminary process selection rationale was established during the study proposal preparation stage and served as the basis for meeting the terms and conditions specified. During the preparation of the study no new facts or information were brought forth to suggest substantial changes in this initial design rationale or processing sequence. Thus the following process rationale has remained essentially constant since the one presented during the proposal preparation stage. We are aware of the future possibility that in order to reduce financial exposure and address construction labor issues, the complex may be built in phases. For example, first phase of construction would be a single upgrading train of 150,000 bpsd. The second phase would then be the second upgrading unit, also of 150,000 bpsd, along with the steam cracker, butadiene and other downstream units. None of the potential construction phasing possibilities would affect the underlying rationale of the processing sequence for the completed, full-scale complex.

It was assumed that process and heat integration of the upgrader, hydrogen production and petrochemicals manufacture would result in a better rate of return to all parties. However, this would have to be balanced against operational flexibility and real life business joint venturing and marketing issues. It was our initial judgment that a nominal capacity of 300,000 bpsd (2,000 tph) of 8.5 API bitumen brought to a facility in the Alberta Industrial Heartland via pipeline from Fort McMurray would provide reasonable economy of scale. The assumed pipeline from Ft. McMurray to the complex, and pipelines from the Edmonton location to potential marketplaces such as the U.S. Midwest are outside the scope of the study. Nevertheless these issues have governed the definition of offsites, especially storage and the inventories of feed and products.

The facility is assumed to be totally powered by electricity. A centrally located steam/power generation plant accepts excess steam from the process units, such as high pressure steam from olefins production, shift-hydrogen production and the sulphur plants and provides electric power to the facility. The facility will be self sufficient in electric power, but also connected to the local electric grid for extra reliability and start up. This approach was selected to obtain lower cost power, higher thermal efficiency and higher reliability.

Given the particular project location in Alberta's Industrial Heartland and the availability of cooling water, all of the heat rejected from the complex will be via cooling water. A tempered water cycle is provided for cooling service in the range of 150°F to 330°F and ultimately this duty is loaded on the cooling water system. Make up water (about 30 million tons per year) to compensate for evaporative and purge losses, will be drawn from the North Saskatchewan River.

#### **3.0.1 Study Strategy**

Fuel products (diesel, gasoline and kerosene) will be the basis. Olefins and hydrogen production will enhance the economics. The study strategy used the following concepts:

- Minimize conversion of bitumen for maximum profit; a higher ratio of diesel to gasoline is produced compared to a "normal" ratio in North American refineries.

- By-products are utilized advantageously as feed for olefins production by steam cracking.
- Low value coke is utilized as feed for producing hydrogen and ammonia synthesis gas.
- Practical, low risk integration with adjacent plants can increase synergism.
- Minimize environmental impact by using the best available economic technology.

As discussed above, an example of process integration with adjacent chemical plants or refineries could be provided by proximity to the Agrium Redwater fertilizer complex. However, this illustration does not exclude other locations pending further studies. On this basis, assumptions as to soil conditions and site preparation issues are identical to the Agrium complex.

As expected, during the execution of the study various ideas arose that could not be evaluated within the scope of the study's terms and conditions. These ideas are briefly discussed later as subjects for further study. The processing steps shown in the block diagram (Appendix A.5, Figure AB-002) represent a feasible configuration and also are the basis for the simplified process flow diagrams, estimating the yields of all conversion units, the heat and material balances and utilities calculations.

The attached tables of physical properties (Appendix A.4) represent the basis for the process configuration. The Steering Committee was advised that a more detailed analysis would be required to confirm the estimated yields in a further project evaluation. Initially confirmation can be made in bench scale units and, prior to project release, in existing pilot plants.

The following items would require such confirmation:

1. True boiling point (TBP) analysis with detailed assay of the estimated 10 cuts.
2. Detailed analysis of metals and trace materials in the bitumen.
3. Coker yield including an assay of each cut.
4. Hydrocracker yield.
5. FCC yield
6. CCR Reformer yield
7. Steam cracking yield of unconverted gas oil.

In addition to the Steering Committee, the yield estimates of the FCC and hydrocracker were reviewed by the National Center for Upgrading Technology (NCUT). The feeds versus products material balance showed over a 99% match. It is the opinion of consultant's team that the estimated yields are of adequate accuracy for the conceptual study. Nevertheless, prior to any further evaluation, additional physical data or further testing will have to be done by NCUT and/or other appropriate parties.

The following key items represent the evolution of our logic in deriving the process scheme. The resultant process scheme is discussed in detail later in Section 4.0 PROCESS DESCRIPTION.



1. Bitumen (300,000 bpsd 8.5 API, 4.9 wt% sulphur, 500 ppm metals, 1.5 vol% naphtha, 1.7% kerosene, 13.9 % diesel, 32% VGO and 50.9 % vacuum residue) diluted upstream with 100,000bpsd naphtha (52 API) enters the feed storage tanks outside the battery limits. Gravity of the mixture of bitumen and diluent is 17 API. The aromatic content of the bitumen on a diluent free basis is 40 wt%. The bitumen is assumed to be significantly acidic with an acid number probably of 3.0-4.0. The naphtha diluted bitumen proceeds to crude fractionation. Based on consultation with NCUT, it was decided that desalting is not likely required; however, the final decision will depend upon the specific bitumen for the project. At this point, no desalting is provided but not totally ruled out if further data would suggest the need.
2. Naphtha diluted bitumen proceeds to atmospheric distillation where a naphtha cut and diesel kerosene cut are fractionated. The great majority of the naphtha cut recycles upstream to the bitumen source. The balance of the naphtha, which equals the original content in the bitumen, about 4,500 bpsd (0.76 specific gravity), is bled off along with coker naphtha for hydrotreating.
3. The 47,000 bpsd of atmospheric diesel (about 25 API), containing approximately 11% kerosene boiling range material, is mixed with other diesel cuts and proceeds to two-stage hydrotreating. Ultra low sulphur diesel is produced in the first stage. Aromatics are reduced and the Cetane number is raised in the second stage. The diesel material is post fractionated after the hydrotreating for separation of the kerosene boiling range material.
4. Atmospheric residue, estimated at 250,000 bpsd (4.5 API) is produced. This represents about 83 vol% of the net feed from the pipeline excluding the diluents. The residue will proceed to two 60% vacuum distillation trains where about 70,000 bpsd of light and medium gas oils (LVGO and MVGO) of about 16 API, 650-900°F cut point is produced.
5. The LVGO and MVGO will be the feed to the hydrocracker. HVGO (heavy vacuum gas oil), 25,500 bpsd, (about 10 API) will be combined with about 47,000 bpsd coker gas oil (about 10 API) and will be severely hydrotreated to produce 75,000 bpsd of desulphurized feed for a conventional FCC (fluid catalytic cracking) unit. The FCC produces FCC gasoline, a light diesel cut, heavy oil and light ends. The light ends is comprised of the C<sub>4</sub>-C<sub>3</sub>s and off gas. The C<sub>4</sub> olefins are alkylated. The propylene and propane are exported to the steam cracker for further olefins recovery. The FCC off gas consists of methane, ethylene, ethane and hydrogen and is also routed to the steam cracker as an advantageous feed for producing polymer grade ethylene. No FCCU power recovery by expansion of flue gas is contemplated for this stage of the study.
6. About 153,000 bpsd of vacuum bottoms (about -1.0 API) is fed to two nominal 80,000 bpsd delayed coking units. Each coker has the optimal number of coking drums, assumed to be four for the Alberta location. After compression and NH<sub>3</sub>/H<sub>2</sub>S removal, coker light ends, consisting of C<sub>1</sub>-C<sub>4</sub>, is an attractive feed for the steam cracker. Excess methane from steam cracking flows to the fuel gas header providing heat energy to the thermal section of the cracker with the balance exported to the bitumen upgrading-refinery section of the complex.

7. Coker naphtha, containing olefins, diolefins and sulphur compounds is mixed with straight run naphtha and hydrotreated to an appropriate level for catalytic reforming feedstock, probably less than 1ppm sulphur.
8. The hydrocracker is a single train, using single pass reactors, with two 50% (2x50%) reactor trains in series. Heavy unconverted gas oil having high hydrogen content and very low sulphur and nitrogen is an advantageous feed to steam cracking along with the hydrocracker light ends. All rotating machinery in the hydrocracker is extensively spared.
9. Delayed coke, nominally 9,000 tpd (metric) from the upgrader is used as feed for partial oxidation. The partial oxidization unit uses 98 vol% pure oxygen to produce hydrogen for hydrocracking, hydrotreating, export OBL and also for ammonia synthesis gas by mixing hydrogen with nitrogen from the air separation unit (ASU). The ASU has a nominal capacity of 9,000 tpd of oxygen in three 3,000 tpd units. Under the scenario of the study, 3,000 tpd of ammonia synthesis gas is sold to Agrium across the fence, which replaces their natural gas feed to two ammonia production units using steam methane reforming with current operational capacity of 2,700-2,800 tpd. Further, under this scenario, the complex also provides 1,500 tpd of pure CO<sub>2</sub> for associated urea production. As indicated in section (7), proposed future study should evaluate the viability of building a complete new ammonia plant rather than synthesis gas integration with the existing Agrium facility.
10. Hydrocracker light-ends, C<sub>1</sub>-C<sub>4</sub>, is an advantageous feed to the steam cracker. Hydrocracker diesel and kerosene are sold on the market. The hydrocracker naphtha is routed to a catalytic reformer to boost its octane rating.
11. The catalytic reformer accepts about 30,000 bpsd of post-fractionated heavy naphtha originating from the hydrocracker, coker naphtha, straight run (SR) naphtha and residual naphtha formed during FCC feed gas oil hydrotreating. Reformate (100 RON) will undergo benzene fractionation. A benzene-free reformate is blended in the gasoline pool. Benzene concentrate, about 25 vol%, is separated from reformate and routed as a feed to the steam cracker. Hydrogen by-product is purified via pressure swing adsorption (PSA) and C<sub>3</sub>/C<sub>4</sub> (liquid petroleum gas, LPG) and C<sub>2</sub>/C<sub>3</sub> rich fuel gas goes to the steam cracker as an advantageous feed.
12. Hydrogen sulfide from all units is over 2,400 tpd and flows to Claus type sulphur plants (two 65% units). Tail gas is incinerated and then scrubbed with aqueous ammonia to produce ammonium sulfite. The ammonium sulfite is subsequently oxidized to ammonium sulfate. The power plant flue gas is scrubbed of SO<sub>2</sub> with aqueous ammonia, producing ammonium sulfite that is subsequently oxidized to ammonium sulfate fertilizer. About 50% of the molten sulphur product may be pumped via a heat-traced pipeline to an Agrium-type plant as a feed to 3,000 tpd sulphuric acid production facilities; however at this point, no credit is given to this future possibility.
13. The boilers are circulating fluidized sand beds where imported coal from OBL is burned to generate steam and power. There are three 50% units to make the facility totally self-sufficient in steam and power while providing enough redundancy to

avoid payment of a demand charge in the event of an unscheduled outage of a power generation unit. Export of excess power produced during normal operation is a reasonable probability but is not credited in the present base case economic analysis, and is a subject for further project evaluation. The power plant is to be equipped with appropriate stack gas scrubbing such as de-NO<sub>x</sub> with ammonia, bag house for fly ash, and as noted, SO<sub>2</sub> removal by aqueous ammonia to produce ammonium sulfite with subsequent oxidation to ammonium sulfate. About 80-90% mercury removal by activated carbon is provided as a future option. The boilers of the power plant are capable of burning fuel gas under the scenario that the steam cracker is down and coker light ends, FCC off gas and hydrocracker light ends are diverted to fuel.

14. Air separation plants (nominal 9,000 tpd of oxygen in three units) produce high purity oxygen at about 1,200 psig as well as pressurized, 2,700tpd nitrogen for nitrogen wash (CO removal) and ammonia synthesis. An additional 1,200 tpd of nitrogen is used for stripping CO<sub>2</sub> in the Rectisol unit.
15. Hydrogen production for the upgrader involves hydrogen purification by PSA at about 800 psig. An appreciable amount of PSA purge gas at about 5 psig and about 80% hydrogen content is recompressed to 800 psig for a secondary PSA hydrogen recovery. Purge gas from this PSA rich in CO is sent to the fuel gas system.

As discussed, our study execution strategy focused on the integration of the major bitumen upgrading refining units with olefins and fertilizers core units that use advantageous feedstocks resulting from the integration. As noted, we are assuming that the driving force of the project is producing finished fuel products for export markets. Petrochemicals production is also very significant and improves the overall project economics. Once the plant configuration is agreed upon, opportunities for additional synergism could be explored, for example, production of polyethylene, polypropylene, styrene, polystyrene, cumene, benzene, p-xylene etc. Nevertheless, the base configuration in the study assumes that polyethylene, which is by far the largest olefin derivative on world market, will be produced either on-site or OSBL. This assumption directs the proposed configuration toward ethylene production. The study assumes ethylene will be pipelined to underground storage for polyethylene and other derivatives manufacture within the province of Alberta. Furthermore, propylene is, assumed to be, shipped in pressurized tank cars for manufacture of petrochemicals such as polypropylene in the province of Alberta.

The C<sub>4</sub> components are separated by extractive distillation. Butadiene is diverted to OBL. C<sub>4</sub> olefins go to alkylation within the upgrader and n-butane is fed to a steam cracker. Under this scenario, a deficiency in isobutane for alkylation is made up by OBL purchases. The study assumes that pyrolysis gasoline, rich in benzene, will be sold and shipped OBL, probably to the U.S. Gulf Coast.

The additional sale of merchant oxygen, merchant nitrogen, and CO<sub>2</sub> beyond that needed for urea processing and the potential recovery of argon and rare gases will be treated as next phase project development items. Future sale of CO<sub>2</sub> for enhanced oil recovery (EOR) or injection for future sequestration may require an estimated 100,000 KW for compression to 2,000 psig. The redundancy in power generation as proposed could be a good fit for such a future application.

### 3.0.2 Simplified Process Sequence

Bitumen, 300,000 bpsd (1.01 specific gravity) contains 5wt% sulphur and is very deficient in hydrogen (only 9.9 wt% hydrogen). Bitumen is mixed with 100,000bpsd diluent (0.76 specific gravity) containing about 14wt % hydrogen. The diluted bitumen is heated by steam and enters two diluent fractionation towers operating at near atmospheric pressure and at about 400°F (204°C). The recovered diluent is pumped back to the source.

To separate a diesel cut, diluent-free bitumen is further heated by fired heaters and undergoes fractionation in two columns operating at about 660°F (350°C) and near atmospheric pressure. About 15vol % of the original bitumen is recovered as atmospheric diesel containing about 3wt% sulphur. This raw diesel requires further treatment to remove sulphur and to saturate the aromatics with hydrogen.

The bottom product of the diesel fractionator, referred to as crude bottoms or reduced crude, is further heated by a fired heater and enters two vacuum fractionation columns that are 40'-0" (12 meters) in diameter and operate at pressure of 20 Millimeters Mercury. The temperature at the bottom of the tower is about 680°F (360°C) and 392°F (200°C) at the top. Because the bitumen is acidic and high in sulphur, the design of this vacuum column requires special attention from a metallurgical standpoint.

Three fractions are formed in the vacuum units:

- (a) About 70,000 bpsd of light vacuum gas oil (LVGO) boiling over the range of 650°F to 900°F corrected to atmospheric pressure,
- (b) About 25,000 bpsd of heavy vacuum gas oil (HVGO) boiling over the range of 900°F to 1050°F corrected to atmospheric pressure and
- (c) 153,000 bpsd of vacuum residue, the heaviest (-1 API gravity, 1.08 specific gravity) and the highest boiling product, boiling from 1050°F and higher.

The LVGO proceeds to the hydrocracker operating at about 2,000 psig under hydrogen pressure at 750°F. About 70% of the LVGO is converted to diesel, kerosene, naphtha and light ends. The light ends and the 30% unconverted LVGO are used as feed for the steam crackers, which mainly produce ethylene, propylene and butadiene. As discussed later, the HVGO proceeds to the fluid catalytic cracker (FCC) where mostly gasoline is produced.

The vacuum residue proceeds to the delayed coker, which operates at approximately 900°F at near atmospheric pressure. The delayed coker feed is thermally cracked to the following components:

- (a) 9 wt% light ends,
- (b) 9 wt% naphtha, known as coker naphtha, which is high in sulphur and olefins,
- (c) 20 wt% coker diesel
- (d) 30 wt% coker gas oil, and
- (e) 32 wt% coke.

The coke is a solid material high in sulphur (about 6.5 wt%), high in nitrogen (about 1.5 wt%), low in hydrogen (about 3.5%) with the rest (88 wt%) being carbon. This is the carbon that is rejected from the bitumen thus elevating the hydrogen-to-carbon ratio in the rest of the bitumen up-graded products.

The delayed coke is mixed with water (about 62 wt% slurry) and proceeds to gasification. In the gasification reactor, the coke reacts with oxygen at about 2,600°F (1,425°C) and 940 psig (65 bars) to produce CO, hydrogen, H<sub>2</sub>S and CO<sub>2</sub>. This gas mixture is known as crude synthesis gas. The crude synthesis gas proceeds to the shift reactor where CO reacts with steam at about 900 psig and 600°F to form additional hydrogen and CO<sub>2</sub>. The product gas at this point is 55 volume % hydrogen, 42% CO<sub>2</sub> 1% H<sub>2</sub>S and 2% CO.

This crude hydrogen proceeds to the Rectisol process, where a cold methanol wash is used to remove and separate from each other the CO<sub>2</sub> and H<sub>2</sub>S. The H<sub>2</sub>S goes to the sulphur recovery plant while the CO<sub>2</sub> is vented. A portion of the CO<sub>2</sub> could be used for producing urea OBL. The 96 vol% pure hydrogen is further purified by PSA (pressure swing adsorption) to 99.9 vol% purity. This hydrogen is routed to the upgrader for hydrocracking and diesel hydrotreating. About one third of the hydrogen along with nitrogen, as co-produced while producing oxygen, is routed to ammonia OBL.

HVGO (25,000 bpsd) and coker gas oil (47,000 bpsd) totaling 72,000 bpsd are mixed and hydrotreated for sulphur and nitrogen removal at about 2,000 psig. The hydrotreated material is feed for the FCC (fluid catalytic cracking) unit. Over 60 vol% gasoline, 15% diesel and 20% light ends are produced. The FCC operates at about 30 psig and 950°F catalytic reaction temperature. Coke is burned at about 1300°F to regenerate the catalyst and to provide the heat for vaporizing and cracking the feedstock. The FCC produces about 6 wt% coke that is burned from the catalyst during regeneration and becomes part of the carbon rejection as needed for the upgrading of the bitumen.

A portion of light ends (the C<sub>4</sub>s), along with isobutane from OBL, is a feedstock for producing C<sub>8</sub>alkylate, a prime motor gasoline component. The C<sub>3</sub> and C<sub>2</sub> light ends are feedstock for the ethylene plant (steam cracker). The ethylene plant accepts nine advantageous feedstocks from the upgrading refinery such as coker light ends, FCC light ends, hydrocracker light ends and unconverted gas oil to produce 900 KT/Y of ethylene. An additional 100 KT/Y of ethylene is produce from feedstock obtained OBL (feed of opportunity).

The octane rating of the entire gasoline blend at this point is about 85 road octane, (R+M)/2, and falls short of the 87 road octane required for regular gasoline. The low octane fractions (about 30,000 bpsd) proceed to catalytic reforming to raise the octane while co-producing hydrogen and light ends. The light ends are fed to the ethylene plant. The reforming operation raises the road octane to 89.9 while the total gasoline production is 98,500 bpsd.

Diesel from several sources (atmospheric diesel, coker diesel and FCC diesel) is hydrotreated at about 1,200 psig to produce a premium low sulphur low aromatics diesel fuel product.

The total diesel production is 120,000bpsd. Hydrotreating of diesel and gasification of coke are co-producers of H<sub>2</sub>S. This H<sub>2</sub>S is routed to two large sulphur plants. The plant is self-sufficient in electric power. The 520 MW of power consumed is generated by combustion of locally mined coal in fluidized bed boilers.

### **3.1 Process Scheme Rationale**

The assumed 300,000 bpsd upgrading capacity needs to be matched to product market development. However an initial analysis would suggest that the train size of the core units would be near their maximum economical sizes. The total production of fuel products (diesel, kerosene and gasoline) would be equivalent to a 225,000bpsd “conventional” refinery while the balance of 75,000bpsd would be diverted to olefins and ammonia synthesis gas production. Both the ethylene and ammonia production represent world scale capacities. We believe this 75:25 ratio of refining to petrochemicals represents a realistic market ratio subject to more specific optimization and marketing analysis by the sponsors. Future expansion could be easily achieved by adding an additional 150,000bpsd train and additional bitumen pipeline capacity.

#### **3.1.1 Atmospheric and Vacuum Distillation**

Because of the relatively low volume of the kerosene cut, about 1.7 vol% of the bitumen, and the estimated 13.9 vol% atmospheric diesel cut, it was decided that no kerosene recovery will take place at the atmospheric fractionation and this kerosene will be combined to the diesel cut and be separated after the diesel hydrotreating stage where some aromatics are saturated. Additional kerosene, about 2% of the diesel, will be produced as a by-product during diesel hydrotreating.

#### **3.1.2 Delayed Coking Versus Deasphalting**

The above process sequence has gone through several evolutions prior to arriving at the suggested scheme. It appeared some sort of atmospheric distillation or flash would be required prior to a vacuum distillation unit. The key question was how to process the vacuum residue. Two options were considered:

- Solvent deasphalting such as ROSE process, probably using butane solvent, licensed by KBR or equivalent processes licensed by UOP/Foster Wheeler and Axens (formerly IFP)
- Delayed coking, such as licensed by Foster Wheeler and ConocoPhillips-Bechtel.

It was recognized that solvent deasphalting requires perhaps 40-50% less capital investment than the delayed coking route and that solvent deasphalting is very successful for bitumen upgrading. Furthermore, we also recognized that hydrogen production via gasification of asphaltine from deasphalting requires 5-7% less capital investment and lower power consumption compared to producing hydrogen via gasification of delayed coke. However deasphalting, unlike delayed coking, is not a conversion process, but rather a precursor to conversion such as FCC or hydrocracking. Thus the investment, or at least the portion of it

associated with conversion, is shifted to other downstream units within the facility or downstream of the product delivery pipeline system.

The metals analysis of the bitumen shows 190ppm vanadium, and 70ppm nickel. We recognize that with deasphalting the vast majority of the metals will carry through to the asphaltene product depending upon several process variables, especially the deasphalted oil (DAO) recovery. Any downstream conversion, particularly hydrocracking, would be very sensitive to metal content and if deasphalting is used, the metal content of the DAO could be well over 10 ppm and very undesirable for fixed bed hydrocracking.

Since the hydrocracking is strategically selected to produce advantageous feed for steam cracking, avoidance of hydrocracking or limiting its capacity to obtain low metal content by forcing low DAO recovery will be detrimental to olefins production. Further, the avoidance of coker light ends and hydrocracker light ends, which are major feed contributors to the steam cracker, would eliminate the olefin option. Based on the above and given the fact that, from our perspective, olefin production was central to enhancing the bitumen upgrading economics, the deasphalting option was not selected.

If asphaltene producing projects materialize in the vicinity of the proposed upgrader, for example the recently announced Shell-Chevron upgrading project in Scotford, some limited amount of asphaltene, say up to about 1,000-2,000bpsd possibly could be imported as a very low cost fuel, using a water emulsion fuel system followed with de-NOx and SO<sub>2</sub> removal as discussed in the utilities and offsites sections of the report.

### **3.1.3 Olefin Production**

Once the delayed coker configuration was selected, the next items on the agenda are the processing units downstream of the vacuum distillation and delayed coking units.

### **3.1.4 Advantageous Steam Cracking Feeds**

Advantageous steam cracking feeds are feeds that could result in a higher rate of return as steam cracker feed than alternate feeds from OBL and in a higher rate of return on the upgrader project compared to producing only fuel products. As shown later, total ethylene production from advantageous feeds is 900 KT/Y. We decided to design the cracker for 1,000 KT/Y with the balance of the feed being feed of opportunity from OBL depending on market cycle. Per our discussion with Nova, we have selected an ethane: propane 65:35 weight ratio as a representative feed of opportunity to increase the cracker capacity to 1,000 KT/Y, above the nearly 900 KT/Y of ethylene attributed to advantageous feeds produced in the upgrader. Propylene, butadiene and pyrolysis gasoline production will be a result of the above ethylene production.

## **1. Hydrocracking Residue**

The common alternate usage for hydrocracking residue is as feed to FCC where the bulk of the conversion product would be FCC gasoline. A second alternate, total conversion of gas oil, as commonly practiced in California, results in a larger hydrocracker unit possibly exceeding the size limitation as discussed in the hydrocracker process description. It was judged that a combination of low conversion hydrocracker and steam cracking of hydrocracker residue would be the more economical utilization of hydrocracker feedstock if ethylene production is a part of the strategic concept. Further, avoidance of the hydrocracker residue as feed to the steam cracker would reduce the ethylene production from advantageous feedstocks to less than 500 KT/Y, making the steam cracking option a dubious proposition.

## **2. Coker Light Ends**

Coker light ends contain about 25-30% olefins and thus would be a very advantageous feed for steam cracking following compression and ammonia and H<sub>2</sub>S removal. Obtaining other coker light ends from local sources could prove to be a very economical option if they should become available. The option of economically pipelining coker light ends from Ft. McMurray is another possibility, but is beyond the scope of the study.

## **3. Hydrocracker Light Ends**

Hydrocracker light ends are a good natural feed for steam cracking that could reduce the capital investment in the cracker. Collection of hydrocracker light ends from other projects in Alberta could be very economical depending on location and transfer price.

## **4. Propane From FCC**

That FCC propane is a good advantageous steam cracker feed similar to the hydrocracker light ends. It was decided that fractionation of C<sub>3</sub> light ends will be conducted in the steam cracking area.

## **5. FCC Dry Gas**

FCC dry gas at about 200 psig (containing about 10-15 vol% ethylene, 12-18 vol% ethane, about 20 vol% Hydrogen and 40 vol% methane) is very a advantageous feed for steam cracking. Traces of CO, NO<sub>x</sub> and other materials in this gas could impact the configuration of the downstream steam cracker.

## **6. N-butane Purge From Alkylation**

N-butane from the alkylation unit is judged to be of higher value for steam cracking than as a gasoline-blending component mainly due to Reid vapor pressure constraints.



## **7. LPG From Catalytic Reforming**

Reformer liquid petroleum gas (LPG) is judged to be an advantageous feed for steam cracking. Steam cracking this LPG avoids the deethanizer and LPG fractionation that normally is done within the boundary limits of the catalytic reforming unit.

## **8. N-Butane From Butadiene Recovery**

The coker light ends contain substantial quantities of n-butane and olefins. This n-butane is a portion of the raffinate in the butadiene extraction process. Further separation of C<sub>4</sub> olefins for alkylation will produce additional n-butane for steam cracking.

## **9. Benzene Concentrates From Catalytic Reforming**

Benzene removal is required to meet gasoline benzene specifications. Removing benzene concentrate (benzene and C<sub>6</sub>/C<sub>7</sub> nonaromatics) and feeding it to a steam cracker will further enhance the project economics.

## **10. Fuel Gas From Catalytic Reforming**

The fuel gas from catalytic reforming is very rich in C<sub>2</sub>/C<sub>3</sub> and C<sub>4</sub>s and thus is more advantageously used as steam cracker feed as opposed to common usage as refinery fuel gas.

### **3.1.5 Conventional Steam Cracking Versus Deep Catalytic Cracking**

An alternate approach to conventional steam cracking could be the emerging concept of HS (high severity) FCC or the DCC (Deep Catalytic Cracking) process. The HS FCC is licensed by UOP. Sinopec through the Shaw Group licenses the DCC process. The premise of HS FCC or DCC is reaction at 100°F higher temperature than FCC, say 1,050-1,100°F, and about double the catalyst-to-oil ratio and resulting in much higher propylene yields, say 17-20wt% as opposed to 13-15wt% in steam cracking and 4-5wt% in conventional FCC. However, ethylene yield is much lower: about 3wt% compared to 27-30wt% in steam cracking of gas oil and 1 wt % in conventional FCC. The gasoline yield would be about 50% lower than the gasoline yield from conventional FCC; but the octane is higher, by about 5-6 points. The DCC gasoline is very high in aromatics, especially benzene, toluene and xylene. Benzene content could be on the order of 3vol%.

The benzene content far exceeds the gasoline pool benzene limitations in the U.S., Canada, Europe and Japan. On this basis, recovery of benzene for petrochemical usage is imperative. Economical recovery of benzene by extraction could become much more viable if the toluene present in FCC gasoline, at least 7.0vol %, is further converted to benzene and xylene by the disproportionation process. Xylenes are then co-produced. The next logical step to enhance the economics is to further convert xylene to p-xylene and the benzene to styrene or other aromatic derivatives.

There are several issues affecting this approach. The steam cracking route proposed for base case lends itself for production of ethylene and major derivatives such as polyethylene,

ethylene glycol and ethylene dichloride. These have by far the larger market share of the petrochemical market compared to the styrene and p-xylene markets. Therefore one strategic marketing decision of the sponsors is which of two alternate objectives should be chosen:

**First objective:** Fuel products production with a base load demand supported by ethylene and propylene derivatives such as polyethylene.

**Alternative objective:** Minimize fuel products production and increase production of propylene and aromatics derivatives such as styrene, polystyrene, cumene and p-xylene.

As far as we can see under the first scenario, the driving force of the project is fuel products enhanced by polyolefins. This is less cyclical than the alternate objective. In the alternate scenario, the economics of the project become more cyclical and subject to the cyclical economics of p-xylene and styrene. Further, the estimated global demand for p-xylene, which is very a capital-intensive process, is far less than the demand for polyolefins.

In the proposed scope of the study, the feeds to the steam cracker comprise nine sources that we classified as advantageous feeds. The hydrocracker residue which is suitable feed for HS FCC, contributes only about 35% of the olefins while the balance (65%) of the olefins are attributed to light feedstock not suitable for DCC. Based on the above, it was decided that conventionally steam cracking the nine proposed advantaged feedstocks is likely to be the more economic solution.

Perhaps once the key upgrading conversion units have been finalized, a potentially viable option could be conversion of the proposed 70,000 bpsd FCC to DCC should the sponsors strategically decide to shift production from fuel products, especially gasoline, to propylene and aromatics. Under this scenario, light ends recovered from DCC in the steam cracker would help the economics of the DCC case. We are advised that the relatively high nitrogen content in the feed to DCC and more so the basic nitrogen “could be a problem” for ZSM-5 catalyst. However, we are not fully aware of all new catalyst R&D efforts.

### **3.1.6 Butadiene Production**

Production of butadiene is a by-product of ethylene production. The coker light ends (after compression to 530 psig and prior to sulphur removal), contains C<sub>4</sub> olefins and n-butane. This stream along with other coker light ends, C<sub>1</sub>-C<sub>3</sub>, and FCC off gas are fractionated for olefins recovery. The resultant C<sub>4</sub> fraction, unlike normal steam cracking feeds, contains a substantial amount of n-butane diluting the butadiene and C<sub>4</sub> olefins. Sending the total C<sub>4</sub> cut outside the boundary limit to the U.S. Gulf Coast is uneconomical. Butadiene is extracted producing a raffinate of n-butane and C<sub>4</sub> olefins. The following three options were evaluated:

- Sending the raffinate to the U.S. Gulf Coast.
- Hydrotreating the raffinate to n-butane and recycling it to the steam cracker
- Splitting the raffinate by extractive distillation; the C<sub>4</sub> olefins will go to alkylation and n-butane will be cracked.

Although very limited experience exists for raffinate fractionation, it was selected over option (2) because of lower capital investment. However option (2) would result in a higher ethylene yield and a lower gasoline yield. This is more of a fine-tuning decision that should be revisited in further optimization studies.

### **3.1.7 Catalytic Reforming Option**

Catalytic reforming was added during the course of this study in order to meet the octane requirement of gasoline blending. There could be four feed sources for the CCR reformer:

1. Hydrotreated heavy coker naphtha
2. Straight run naphtha from atmospheric distillation
3. Hydrocracker heavy naphtha
4. Residual naphtha from FCC gas oil hydrotreating.

Since these sources are rich in benzene and its precursors, fractionation of reformat benzene concentrate will be needed to meet the benzene specification of the total gasoline blend, especially for reformulated gasoline. As noted previously, the benzene concentrate is an advantageous feed to the steam cracker.

### **3.1.8 Gasification Of Coke**

It was concluded that hydrogen production by gasification of low or zero and perhaps even negative value feedstock is by far more economical than hydrogen production by steam reforming of natural gas, especially when the local price of natural gas is above \$4.00 US/MM Btu HHV. Given the facts that hydrogen is the key downstream product and requires severe water-gas shifting, the quench mode of the General Electric process (formerly the Texaco process) or an equivalent process would be the most appropriate for this application. A nominal gasification pressure of 940 psig (65 bars) is assumed when the coke is fed to the gasifier as heavy aqueous slurry, 61 wt% coke, where 1% of a fluxing agent such as ash from coal fired boilers would be used.

### **3.1.9 Oxygen, Nitrogen And Argon Production**

Once the decision is made to produce hydrogen via partial oxidation of low value feed, production of oxygen via air separation units (ASUs) is required. Once ammonia synthesis gas is chosen, production of nitrogen free of oxygen is imperative.

All methods of large scale ASUs require these process steps: atmospheric air compression (typically to 90 psig), air drying, cryogenic fractionation of liquefied air, cold recovery, oxygen compression or liquid oxygen pumping and, in our proposed case, nitrogen compression for ammonia synthesis gas. The ASU air compressors and associated drying system will reduce the redundancy required in the plant air and instrument air.

The oxygen purity could vary from 95.0 to 99.7 vol% depending on overall process optimization and argon recovery. Oxygen compression, say to 1,200 psig, compared to oxygen pumping is also a function of many factors. Steam turbine compared to electric motor drive is also a very important issue and is discussed later. Future argon recovery and

downstream hydrogen purification issues lead us toward an oxygen purity of 98 vol% where almost all the balance 2.0% is argon.

Recent experience with oxygen compression causes us to lean toward conventional compression via centrifugal compressors. But all these initial recommendations will be finalized after further direction on argon marketing issues and technical discussions with the selected providers of ASU technology. At this point all the ASU issues could be considered secondary in nature. It is assumed three ASU trains will be required with only one nitrogen compressor connected to all three ASU.

### **3.1.10 Shifting Carbon Monoxide To Hydrogen**

It was judged, based on prior experience, that sour shifting some 95% of the CO to H<sub>2</sub> and CO<sub>2</sub> and 88-90% of the COS to CO<sub>2</sub> and H<sub>2</sub>S at about 520°F and in two stages would represent the optimum process configuration. It is estimated that three shift trains will be required. Quenched synthesis gas from the gasification (after a partial condensation of steam and 300 psig steam generation) will have more than adequate residual steam to carry out the proposed shift reaction. The exothermic heat of the shift reaction will be recovered as steam at 1,030 psig (550°F, 900 psig flange rating) to be used for hot fractionation services in the upgrader. Purge gas from three PSA units (at 5 psig contains about 14 vol % CO and 5% N<sub>2</sub>+A+CH<sub>4</sub>) is recompressed to 800 psig using rotary compressors to 60 psig followed by reciprocating compressors to 800 psig prior to shifting in a single purge PSA unit for further hydrogen recovery. The CO rich residue gas from the purge PSA unit is compressed to fuel gas header pressure (80 psig).

### **3.1.11 Acid Gas Removal**

Given the large volume of CO<sub>2</sub> in the shifted gas (about 42 vol % on a dry basis) and the presence of high H<sub>2</sub>S (about 1.5 vol%) and residual COS (40 ppm), a physical solvent is the only viable solution for removing CO<sub>2</sub>, H<sub>2</sub>S and COS. This removal is necessary to meet the requirement of the down stream ammonia synthesis loop and more so for the CO<sub>2</sub> to be delivered to urea production.

Two solvents are available on the market: UOP's Selexol solvent and Linde AG or Lurgi Oil & Gas Rectisol's methanol solvent. Based on past experience including process simulation, cost estimation and economic analysis while considering the application of CO<sub>2</sub> to urea and the ammonia synthesis catalyst's sulphur limit of 0.1 ppm, it was decided that Rectisol is the more economical approach. The major reason is the much higher selectivity toward COS and lower viscosity compared to the Selexol solvent. It is estimated that three Rectisol trains will be required, two dedicated to hydrogen for the upgrader and one for ammonia synthesis, each unit with a separate refrigeration system.

### **3.1.12 Hydrogen Purification And Fuel Gas**

A quick evaluation suggested the liquid nitrogen wash process is more economical than PSA for the ammonia synthesis gas. We recognize that in recent years a few ammonia plants based on hydrogen originated from PSA have been built.

Additional fuel gas equivalent could be obtained by emulsifying the low sulphur, low metals heavy oils with water (30 wt% at 160°F) to form a fuel almost equivalent to natural gas. Heavy pyrolysis oil and FCC slurry oil (after filtration of catalyst) could be excellent sources. Importation of asphaltene or other low value fuel oil is the selected option for achieving fuel balance. For asphaltene and other OBL fuel oils, stack gas scrubbing of SO<sub>2</sub> and de-NO<sub>x</sub> with ammonia will be required.

### **3.1.13 Sulphur Recovery And Tail Gas Treating**

Sulphur recovery will be via conventional Claus sulphur plants. Estimated sulphur recovery of 96.5% is assumed at the start-of-run and 94% at the end-of-run. The tail gas of the sulphur plant will be incinerated. Tail gas scrubbing with aqueous ammonia solution is contemplated to produce ammonium sulfite and subsequently oxidized to ammonium sulfate. Normally, some 8-10% of the H<sub>2</sub>S feed to the sulphur plant is expected to be an ammonia rich stream obtained from the sour water strippers. It would contain some 100-130 tpd of ammonia that would be thermally oxidized in the sulphur plants. In this particular situation we have selected the Chevron WWT technology for ammonia recovery from sour water. The recovered ammonia will have traces, say 5 ppm, of H<sub>2</sub>S and will not meet the specifications for urea or nitric acid production. However this lower grade ammonia would be excellent feed for producing ammonium sulfate and probably other applications. It should be noted that avoidance of ammonia in the sulphur plant, aside from reducing capital cost, will have a very positive influence on the on-stream factor.

### **3.1.14 Alkylation System**

As discussed, conventional fluid catalytic cracking of coker gas oil and heavy vacuum gas oil has been selected for the project. The estimated 75,000 bpsd of hydrotreated feed could yield sufficient C<sub>4</sub> olefins to produce about 11,000 bpsd of C<sub>8</sub> alkylate with RON of 95 to 96. This is considered a superior gasoline blending stock, especially for California Air Resources Board (CARB) gasoline. Additional C<sub>4</sub> olefins from steam cracking sources combined with imported iso butane will increase C<sub>8</sub> alkylate production to 16,000 bpsd.

Three alkylation systems could be considered:

- HF alkylation, which is practiced in western Canada
- Sulphuric Acid alkylation, which is capturing the largest market share
- Newly emerging solid acid alkylation

The first commercial solid acid alkylation is scheduled to go on stream in Baku, Former Soviet Union in 2008.

It is our assumption that getting environmental permits for HF alkylation will be more difficult than for sulphuric acid alkylation or solid acid alkylation. We have decided, to use the solid acid alkylation option and leave the issue in next stage of project development to re-examine the options of sulphuric acid and HF alkylation.

### 3.2. Utility Rationale

#### 3.2.1 Steam Turbine Versus Electric Motor Drive

This issue was given considerable thought. The power consumption was estimated in the proposal to be on the order of 500 MW for establishing the design rationale. Here is an estimated order of magnitude power consumption of the major end-users at peak summer conditions. In most cases, these users could be steam driven.

ASU	KW
Air compressors, 3 x 38,000 KW	114,000
Oxygen compressors, 3 x 18,300 KW	55,000
Nitrogen compressor	18,000
Cooling water pumps in ASU	3,000
Subtotal ASU	190,000

Gasification	KW
Coke grinding, 3 x 2,000 KW	6,000
Coal slurry pumping	2,000
Grey water pumping	2,000
Rectisol refrigeration	28,000
Rectisol circulation pumps	13,000
Shift pumps to quench section	2,000
PSA purge gas compression	23,000
Subtotal hydrogen synthesis-gas generation	266,000

Steam Cracker/Butadiene	KW
Cracked gas compressor	35,000
Propylene refrigeration	28,000
Ethylene refrigeration	17,000
Butadiene extraction	2,000
Cooling water pumps	1,000
Subtotal cracker	83,000

In the upgrader area major users will be:

Upgrader Major Users	KW
Hydrocracker power (include 13,000 KW compression)	20,000
Diesel hydrotreater recycle compressor, two 7,000 KW	15,500
Crude unit	2,000
Vacuum unit	2,000
Sulphur plant air blowers, two 1,750 KW	3,500
Delayed coker cutting water pumps	10,000
Coker light end compressor two 7,000 KW	14,000
FCC air compressor	21,000
FCC wet gas compressor	10,000

FCC pretreating compressor	7,000
Coker naphtha recycle compressor	2,000
Reformer CCR recycle compressor	4,500
Reformer net gas compressor	7,000
Alkylation refrigeration	2,000
Cooling water/tempered water pumps	9,000
Instrument air compressors	2,000
Subtotal upgrader	134,500

Instrument Air and Miscellaneous	KW
Instrument air steam cracker	1,000
Instrument air hydrogen plant	1,500
Liquid products transfer to storage	500
Miscellaneous lighting HVAC	2,500
<b>Total net power</b>	<b>489 MW</b>

The auxiliary power dedicated to steam power generation is: boiler fans (550,000 scfm 80" WG), 9,000 KW, cooling water (280,000 gpm) circulation, 8,000 KW, cooling tower fans, 2,000 KW, boiler-feed water pumps (8,000 gpm), 10,000 KW, condensate pumps 1,000 KW and coal grinding, 1,000 KW. The power plant auxiliary power totals 31,000 KW for a total power generation output of 520,000 KW. Allowing 1.5% generator losses and 2% distribution losses brings the power generation turbines load to 538,000 KW. On this basis the total gross nominal power generation for process design purposes will be 540 MW, generated by three (two plus one spare) 270 MW turbines.

The great majority of steam crackers are fully steam driven, but we are aware of two exceptions. In the proposed case, 417 tons/hour (920,000 lb/hr) of 1,800 psig, 975°F steam, expected to be produced by the TLE (transfer line exchangers), would normally provide all the motive energy for the steam cracker compressors making them self-sufficient in steam and not dependant on outside power.

Further, many crackers are designed for flexible feedstock where the molecular weight (about 24.0) of the cracked gas could vary, probably by  $\pm 5\%$ , thus variable speed compressors seem to offer some advantage. In spite of this consideration, here are the specific reasons that caused us to shift from steam turbines to electric motors:

1. Synchronous motors larger than 50,000 KW are commercially proven.
2. ASU operating experience shows a 10% reduction in capital investment when using electric motors plus lower maintenance and a higher on-stream factor.
3. As far as the steam cracker is concerned, due to the need to avoid tar depositing in the TLE exchangers of the liquid crackers, a steam generation pressure of at least 1,800-1,900 psig is recommended. This pressure is unrelated to issues of steam cycle efficiency. A start-up boiler in the steam cracker will be avoided and start-up steam will be obtained from the power generation section.
4. The above steam pressure is extremely synergistic with conventional power plants equipped with a reheat cycle where typically 1,800 psig (1,050°F) steam is expanded to 300-550 psig, about 300 psig in this case. The 300 psig (585°F) steam, after

merging with 300 psig saturated steam from gasification, is being re-superheated in the boiler to 270 psig (770°F).

5. The turbine efficiency in constant speed power generation is on the order of 88-90% polytropic efficiency as opposed to the 81-83% efficiency of three dimensional variable speed turbines. We recognize that there will be about 1.5% generator losses when converting steam energy to electric power, but the overall gain in the power cycle is still very significant.
6. The addition of a re-superheat cycle for the 1,900 psig steam from the steam cracker, combined with the higher polytropic efficiency of the power generation turbines, will increase the overall steam cycle efficiency; will reduce the capital investment and maintenance. This would be even more the case in locations that can achieve lower cooling water temperatures. Our site is such a location.
7. In addition to all of the above, since the capacity of the electric power grid in the Edmonton area is large, no issues of startup of 40,000 KW synchronous electric motors are expected to arise. Avoidance of the need for heat tracing of all the condensate systems is a big advantage.

Finally using the concept of electric power generation has an additional advantage: instead of having a complex heat integration of the hot streams in the refinery, all these heat sources or heat sinks could float on the power generation steam system either extracting or admitting steam.

### **3.2.2 Redundant Capacity In Power Generation**

The subject of redundancy has gone through several evolutions after evaluating probable issues related to the tie-in to the local power grid and resulting demand charges. The demand charge could be a significant project factor for availability of a large power block on the grid, for purpose of emergency and not scheduled maintenance of the steam/power generator. The issue is a subject to negotiate with AESO (Alberta Energy Supply Operator) during the further development of this type of project.

On the basis of current practice, the demand charge for instant purchase of power could be very significant. On this basis we have decided to use three 50% coal fired boilers and power generators. Each of the power generators will be normally operating at 66% capacity as a base case for this study. Given the fact that about 40% of the power is attributed to steam generated in the process area, by operation of the boilers at 100% capacity the export power to the grid could be 170 MW, probably on a discounted interruptible basis.

### **3.2.3 Air Cooling Versus Water Cooling**

At the proposed site there is adequate water available from the North Saskatchewan River, probably some 3,700 M<sup>3</sup>/hr. For hot services cooling, say 350°F to 150°F, scaling on the cooling waterside is a valid concern. Our team recommends a tempered water cycle using ethylene glycol-water at 130-160°F and transferring the heat from the tempered water cycle to the cooling water circulating from 75°F to 110°F under summer conditions. Reverting to air-cooling could save some 20% of the cooling water. The total water consumption is about 0.5% of the flow of the North Saskatchewan River.



## **4.0. PROCESS DESCRIPTION**

Because several industries: refining, petrochemicals, industrial gases and power generation are involved, deriving consistent flow diagrams with consistent numerology was a difficult task. It is recommended that once the concept is further developed consistent flow diagrams be developed for all units. For this report, the process design drawings as shown in Appendix A.5 are only for process illustration purposes and not necessarily 100% consistent with each other in terms of standards and level of details.

The development of the individual flow diagrams was heavily influenced by the availability of confidential and sensitive information from third parties sources and timing consideration in executing the study. At the end of the day the objective of the study was to reach a base case process configuration on a conceptual level that would lead to a credible cost estimate, utilities estimate and overall first pass economic analysis. The sole purpose of the flow diagrams is to allow the sponsors and potential investors to understand the concept and not necessarily be a basis for detailed process design.

### **4.1. Conversion Section**

#### **4.1.1 Crude (Distillate Recovery) And Vacuum Units**

The proposed crude oil distillation unit reflects the very unusual physical properties of the bitumen. The assay of the crude and true boiling point (TBP) distillation curve as provided by the National Center for Upgrading Technology (NCUT) in Canada is not in full agreement with other published data. The NCUT data shows a significant salt content thus requiring a desalting operation. Other data suggests that for some bitumen mining operations, the resultant bitumen is totally free of salt. TBP as provided by NCUT shows an initial boiling at 450°F (250°C) and neither light ends nor naphtha are present. Other published data shows 1.5 vol% naphtha and 1.7 vol% kerosene boiling range oil.

After further discussion with NCUT, it was decided that no desalting will be incorporated into the design. We assume that the 1.5 vol % naphtha may originate from other sources such as un-recovered diluents. On this basis the TBP was corrected to reflect this assumed naphtha content.

Both the crude and vacuum distillations are less heat integrated compared to conventional crude and vacuum units of common petroleum refining. Heat from the crude and vacuum fractionations is recovered by generating primarily 300 psig saturated steam and 50 psig steam. Steam at 130 psig, 300 psig and 1,030 psig (550°F) is used where practical to provide heating and fractionation duty. Low level heat below 330°F that normally would have been rejected to air coolers or cooling water is used to preheat the bitumen feedstock.

It is recognized that such a method using steam as a heat carrier results in somewhat lower thermal efficiency. However transferring and recycling heat energy via medium and high-pressure steam is more economical than moving around large quantities of hydrocarbons at low pressure and low heat capacity.

The associated capital cost in piping and heat transfer equipment would be lower as compared with the common fully integrated heat recovery. The economics of this concept is even improved, especially where there is a “home” for any excess steam in power generation and additional steam to meet any deficiency would be provided by extraction from the steam turbines firing coal in the boilers of the proposed power plants. This heat energy ultimately would originate from coal, which is priced in the study at \$0.73 US/MM Btu instead of “normal” fuel gas heat energy valued at \$8.00/MMBtu.

### **Crude Distillation (Diluent Recovery)**

Figure AB-003, Appendix A.5, is the flow sheet of the crude distillation and diluent recovery section. Naphtha diluted bitumen, 400,000 bpsd (estimated 17 API) is maintained at 160°F in the storage surge tanks (T-101) by internal coils using 180°F tempered water from various process units. As naphtha diluted bitumen is pumped to the naphtha fractionator (V-101 A/B) it is first heated in exchanger E-101 by condensing vaporized diluents. The diluted bitumen recovers heat from a pump-around loop on V-101 in exchanger E-102. Steam heaters E-103 and E-104 further heat the diluted bitumen to 450°F.

Flashing of diluents starts in E-103 using 130 psig steam (360°F) and more flashes in E-104 with 1,030 psig (550°F) saturated steam. The mixture enters the flash zone of V-101 A/B at about 450°F but could be controlled in the range of 400-500°F as required for operational flexibility and depending on the boiling characteristics of the diluent. The flashed mixed phase feed of bitumen and diluent enters tray four of the diluent recovery flash drums V-101 A/B. These drums are equipped with 9 trays, a pump around loop and steam stripping to assure reasonably good separation of material boiling below 400°F. Overhead pump-around pump P-104 draws liquid at about 420°F (600,000 lb/hr, total of both trains). The pump-around liquid is cooled in exchanger E-102.

Overhead naphtha product (105,000 bpsd) from V-101 along with injected steam is condensed in E-101 and E-105. Steam condensate is separated in V-105 A/B and liquid diluent is routed to diluent surge tank T-102. About 100,000 bpsd of diluent recycles upstream for bitumen dilution. The balance (4,500 bpsd as shown in the actual material balance) is the net naphtha product that is mixed with coker naphtha and subsequently hydrotreated for continuous catalytic reformer (CCR) feed.

The bottoms from the naphtha flash drums (V-101 A/B) (about 295,000 bpsd containing kerosene 5,100 bpsd kerosene cut and 41,700 bpsd diesel cut material) at about 460°F proceeds to the diesel fractionator (V-102 A/B) via steam heater E-107, which heats it to 520°F using 1,030 psig steam. About 950,000 lb/hr of 1,030 psig condensate is flashed at 50 psig producing a substantial amount of 50 psig steam.

Flashing to 130 psig is also an option. Exchanger E-108 uses heat recovered from the 680°F vacuum residue to preheat the material to 575°F before entering H-101, the diesel fractionator fired heater. Heat is recovered from the heater flue gas by generating 300 psig steam and 50 psig steam and superheating 50 psig steam. The low-pressure steam is superheated to 750°F. Diesel rich material is flashed in the flash zone of V-102 A/B.

Twelve actual trays and steam stripping of the bottoms helps maximize atmospheric diesel recovery. Stripped atmospheric diesel is blended with about 11% kerosene cut that is separated downstream after the diesel hydrotreating unit. No atmospheric gas oil (typically about 700-750°F) is recovered here. This cut is recovered in the vacuum unit as part of the light vacuum gas oil (LVGO). It was judged that in this particular case, avoidance of atmospheric gas oil (AGO) represents the more economical solution. Because of the high acid number of the bitumen (mostly naphthenic acid) chromium alloy cladding is incorporated into the diesel recovery flash drum. Injected steam (50,000 lb/hr) is condensed and the condensate is separated from the diesel cut in separator V-104 A/B.

Diesel overhead product from V-102 A/B at 640°F is cooled to 450°F by generating 300 psig saturated steam in E-112 followed by generating 50 psig steam in E 105 and finally cooled to 160°F in tempered water cooler E-106. The diesel then proceeds to hot intermediate storage or to diesel hydrotreating. Bottoms product from diesel recovery column V-102 A/B at about 690°F proceeds to vacuum distillation.

### **Vacuum Distillation**

The design of the vacuum unit (Figure AB-004) is closer to a conventional design; however, the relative rate of vacuum bottoms is very high. The vacuum columns (V-202 A/B) are 40'-0" ID with 316L stainless steel cladding. The bottoms of the crude unit diesel fractionator (V-102 A/B) at 690°F enters the vacuum heaters (H-201 A/B) operating at about 150 mm Hg pressure and flashing at about 780°F (consuming 410 MM Btu/hr LHV absorbed total process duty, 540 MM Btu/hr LHV firing duty). Steam at 300 psig and steam at 50 psig are generated in the waste heat recovery section of the heater.

Additional flashing occurs in the flash zone (35 MM Hg) of V-202. To avoid coking, recycle vacuum residue at 600°F is quenching the tower bottom to 680°F.

Two vacuum unit distillate products are made:

1. 70,000 bpsd of LVGO (Light vacuum gas oil) containing about 5-10% AGO (atmospheric gas oil), 650-900°F, and
2. 25,500 bpsd, of HVGO (Heavy vacuum gas oil), 900-1050°F.

The LVGO is drawn from the top reflux pump around at about 420°F. The HVGO is drawn from near the bottom pump around at about 550°F.

The LVGO is routed to hot storage (not shown) at 330°F and HVGO is routed to hot intermediate storage at about 450°F after undergoing heat recovery by generating 300 psig and 130 psig saturated steam in E-201 and E-203 respectively. The vacuum, bottoms at about 680°F is cooled to 600°F by preheating the feed to H-101 at E-108 in the crude unit area. Vacuum (about 15 MM Hg at the top) is generated by three-stage ejectors using 300 psig saturated steam. Condensed steam (about 80,000 lb/hr), contaminated by hydrocarbon from the hot well, is routed to the gasification area. Given the relatively low cost of steam the concept of wet vacuum distillation with steam injection deserves further evaluation in further project development.

### 4.1.2 Delayed Coking

Delayed coking (Figure AB-005) is the most significant conversion process in the complex and not surprisingly the most capital intensive. The feed to the coker comprises 153,000 bpsd of vacuum residue (-1.0 API, 1.084 specific gravity, estimated 6.0 wt% sulphur). The majority (75-90%) of the feed at 600°F comes directly from the vacuum units after further cooling in the crude units. The balance (10-25%) comes from intermediate storage at 350-400°F. Two coking trains of 80,000 bpsd are contemplated. Given the location and size limitations, four drums, two heaters and one fractionator per train would be the likely configuration as opposed to a more typical six drums found in U.S. Gulf Coast.

In principle the coking operation is a process of massive carbon rejection via thermal cracking. Vacuum residue containing about 9.5 wt% hydrogen is broken down to three phases:

1. Liquid, 58 wt% yield, comprising naphtha, diesel and coker gas oil
2. Solid delayed coke, about 33% yield, containing 3.6 wt% hydrogen
3. Vapor, 9.0 wt% yield, comprising H<sub>2</sub>S, ammonia, and C<sub>1</sub>-C<sub>4</sub>.

### Coker Yields

The following coker yields were obtained from private industry sources for a bitumen derived -1.0 API (1.084 specific gravity, 6.0 wt% sulphur) vacuum residue material:

	<b>Wt%</b>	<b>Properties</b>
Hydrogen Sulfide	1.80	
Hydrogen	0.05	
Methane	1.8	
Ethylene	0.25	
Ethane	1.7	
Propylene	0.6	
Propane	1.4	
Butylenes	0.5	
Butanes	0.8	
Coker Naphtha	8.5	55 API
		PONA: 15/30/40/15;
		3.5 wt% Diolefins
		1.6 wt% Sulphur
		Nitrogen, 0.30 wt% estimated
Coker Diesel	19.3	
Coker Gas Oil	30.0	70 wt% Aromatics 1.2 wt% Conradson Carbon
Coke	33.3	6.45 wt% Sulphur

The coker light ends contain about 2% acetylenes and diolefins plus also minimal traces of arsine, mercury and other impurities. These trace impurities could be of significance in downstream acetylene conversion reactor of the steam cracker. Properties of the coke product on a dry and ash-free basis are:

Carbon	88.58 wt%
Hydrogen	3.60
Sulphur	6.45
Nitrogen	1.37
Nickel plus Vanadium	1689 ppm
VCM	8-12 wt%
High (Gross) Heating Value	8,571 Kcal/Kg
Low (Net) Heating Value	8,383 Kcal/Kg
Coke Moisture	12 wt%

### Coking Process Description

Vacuum residue (-1 API) from either storage or directly from the vacuum unit or a combination of the two is routed to two 80,000 bpsd cokers. The colder feed (about 350-450°F, typically 10-25% of total feed) is fed to the colder section of fired heater (H-1) and the hot feed, say about 600°F, is fed to the bottom section of the fractionation column (V-3) and recycles to the hot section of H-1. Typically the majority of the feed (75-90%) is hot feed. A mixture temperature of 550°F would represent a good average for the utilities calculations. The oil is heated to about 925°F with very short residence time in the coil thus avoiding any significant coking of the tubes. The furnace fuel of choice will be a combination of fuel gas and low sulphur, emulsified heavy oil. The SO<sub>2</sub> and NO<sub>x</sub> emissions would be very minimal and no further emission control would be required. The power of the combustion air blowers is about 300 KW per train. The ratio of fuel gas to fuel oil will depend on the instant fuel balance in the refinery but the total firing duty is expected to be about 475 MM Btu/hr LHV per 80,000 bpsd train, a total 950 MM Btu/hr LHV.

The hot oil at about 925°F is fed to the appropriate coke drum (V-1, V-2) depending upon the decoking cycle as discussed later and flashed. A long residence time in the drum results in thermal cracking of the feed to produce solid coke product. The flashed vapor from the coke drum is routed to the bottom section of the coker fractionator (V-3). The bulk of the vapor condenses and heat is recovered through the pump around via exchanger E-10, generating about 150,000 lb/hr of 300 psig saturated steam per train for a total of 300,000 lb/hr of steam.

The side products are:

1. Heavy coker gas oil (10 API) via side stripper V-6
2. Coker diesel (35 API) via side stripper V-5
3. Coker naphtha (55 API) via reflux drum V-7
4. Sour water containing ammonia and H<sub>2</sub>S about 350-400 gpm per train from V-7

Steam is injected into the side strippers (V-5, V-6), ultimately condensed at the overhead condensers (E-2, E-3) and removed from separator V-7 with all the ammonia produced, about 30 tpd (1.25 tph) and some of the H<sub>2</sub>S. The ammonia-free light ends is compressed from 2 psig to about 150 psig in two stages by wet gas compressor (C-1), about 4,000 KW per train. The light ends combines with FCC dry gas and proceeds to MDEA H<sub>2</sub>S absorber (V-12). Water condensate is knocked out at the lower section of V-12 and the bulk of the H<sub>2</sub>S is removed by MDEA solution (50 wt%) in the upper section. Coker light ends (6,950

lb-mol/hr) combines with 4,300 lb-mol/hr of FCC off gas (containing some H<sub>2</sub>S) prior to H<sub>2</sub>S removal by lean MDEA solution for bulk sulphur removal. This desulphurized gas is further compressed to 550 psig in two additional stages of C-1 (2,800 KW per train). The total compression power of all four stages is 13,600 KW of which 9% is attributed to FCC off gas. The 550 psig compressed gas is routed to the caustic scrubber of the steam cracker for removal of the residual trace of sulphur. Coker naphtha from V-7 provides the reflux to the fractionator. Net product (18,600 bpsd) is routed to the coker naphtha hydrotreater.

The coke drums are operated in batches. In this case the cycle time is about 36 hours: 18 hours filling and 18 hours preparation time including de-coking with high-pressure cutter water. This cycle needs to be optimized during the detailed design. As of now the assumption is two drums are filling with coke while two drums are being decoked and prepared. The cutting of the coke is estimated to take about 25% of the time. Cutting water at 5,000 psig and an estimated 1,500 gpm is pumped by a multi-stage pump (4,500 KW per train). The cooling operation produces a large quantity of very low-pressure (15 psig or less) steam that is condensed and recovered in the coker blow-down system (V-10). The vented blow down gas is routed to a wet gas compressor.

Since some minimal coking may occur in the heating coils, periodic (say every 3 months) decoking of the coils is done by steam-air decoking by isolating one coil while the remaining coils continue to operate. Given the fact that 100% of the coke is internally consumed in the gasification facility, no limitation on coke loading of rail cars or trucks, exists. The coke is down loaded into a 10,000 ton capacity storage pit per train. Storage capacity of crushed coke (less than 2" diameter) is 48 hours. An enclosed conveyor transports the crushed coke to the coke grinding area of the gasification, hydrogen production facilities.

#### 4.1.3 Hydrocracking

The design basis of the hydrocracker (Figure AB-006), Appendix A.5, is as follows:

Nominal capacity: 70,000 bpsd (444 tph) of light vacuum gas oil (LVGO)

Estimated LVGO properties:

Boiling range, °F	650-900
Gravity, API	16
Hydrogen, wt%	11.5
Aromatics, wt%	40
Sulphur, wt%	3.3
Nitrogen, ppm	1,200-1,500
Metals, ppm	Less than 2
Conradson Carbon Residue, wt%	Less than 0.1

1. Single pass, single stage design for maximizing diesel fuel
2. Conversion: 75% start-of-run; 65% end-of-run
3. Use 68% conversion in the material balance
4. Maximum vessel weight: 800 tons

## 5. Maximum wall thickness: 12 in.

All the above was the basis for estimating the yield and hydrogen consumption and also for determining the design parameters and ultimately the conceptual design and cost estimate. Because of the limitations of weight, wall thickness and nitrogen content along with the desired conversion, it was assessed that a single stage conversion, physically comprising two converters in series would be a good basis for further optimization.

By interpolation of the yield curves for similar feedstocks, the hydrocracker pressures were conservatively estimated, subject to corroboration of pilot plant testing, to be: 2,050 psig operating pressure, 2,250 psig design pressure and 1,950 psig hydrogen partial pressure. The estimated net hydrogen consumption is 1,670 Scf /bbl (2.56 wt%). After allowing a safety margin in the hydrogen balance of 90 scf/bbl plus an additional 80 scf/bbl for solution and purge losses (with ultimate recovery in PSA unit), the total calculated hydrogen consumption is 1,840 scf/bbl.

Based on all the above, two reactors (13'-0" ID, 15'-0" OD, 66'-0" TT) will reach the 800 ton weight limit and provide a  $0.9\text{hr}^{-1}$  space velocity. The space velocity, of course, is function of the catalyst used. It is thought that an amorphous catalyst from the series of DHC-8 catalysts typically used in the Unicracking process is likely to meet the specification at a conservative space velocity. Further it is our judgment that single stage reactors each having three beds, total six beds per reactor stage will present a conservative approach in a single stage HDS/hydrocracking reactor. Based upon recently published data, it is reasonable to assume that with a more modern catalyst, a space velocity of  $1.4\text{hr}^{-1}$  could be achieved. This could reduce reactor sizes by 35% while maintaining the same conversion.

### **Hydrocracking Process Yield**

The cracking yields shown in Table 4.1.3 were estimated based on 70,000 bpsd (444.0 tph) of feedstock at middle of run conditions.

### **Hydrocracking Process Description**

Light vacuum gas oil (LVGO) from the vacuum unit at 330°F proceeds normally to hydrocracking with a portion going to storage at 180°F. For estimating the heat balance we used 300°F as the temperature of the combined feed to the hydrocracker. However, the hydrocracker is capable of handling feed temperatures in the range of 180°F to 450°F.

### **Conversion Section**

Fresh feed from the feed surge drum (V-1) at 180-450°F is pumped at 2,200 psig and preheated in exchanger E-15 to a controlled temperature as dictated by heat balance and other process considerations. Preheating to about 450°F by heat recovery from products (not specifically shown) would be a good practice. Hydrogen makes up compressors C-1 A-C (6,000 KW operating using three 50% reciprocating compressors) compress purified hydrogen from PSA at 800 psig inlet pressure. This hydrogen (about 14,150 lb-mol/hr) comprises over 99.9 mol% hydrogen at 2,200 psig and contains less than 1,000 ppm argon

and less than 50 ppm CO. Make up hydrogen and a portion of the total recycle hydrogen (about 75,000 lb-mol/hr) comprising over 90% hydrogen enter E-1, a multi-shell heat exchanger, and are reheated at the reactor heater (H-1) to reactor temperature of about 720°F prior to entering the hydrocracker reactors (V-2). The reactor comprises two reactor vessels in series.

The fuel to the heater H-1 (about 80 MM Btu/hr LHV firing duty) will comprise refinery fuel gas originating from steam cracking and hydrogen plant PSA purge gas. Heat recovery from flue gas is accomplished by preheating boiler feed water prior to steam generation in H-2 as described later. The heat of reaction in the hydrocracker catalyst bed is in the order of 60 Btu/scf of hydrogen reacted. The following would represent the reaction in very simplified way:

1. Desulphurization of the feed to very low level
2. Denitrification of the feed to very low level
3. Breaking the LVGO molecules (average molecular weight about 500 to 200)
4. Saturating over 50% of the aromatic rings, especially multi-rings.

**Table 4.1.3 Hydrocracking Yields**

<u>Gaseous Products</u>	<u>Yield, wt%</u>	<u>Flow, tph</u>	<u>Properties</u>
Acid Gas			
H <sub>2</sub> S	3.5	15.5 (373 tpd)	
Ammonia	0.15	0.66 (16 tpd)	
Light Ends	4.2	18.4	
Methane	0.40		
Ethane	0.45		
Propane	1.40		
Butanes	1.95		
<u>Liquid Products</u>	<u>Yield, vol%</u>	<u>Flow, tph (bpsd)</u>	<u>Properties</u>
Light Naphtha (C <sub>4</sub> -C <sub>6</sub> )	10.0	31.0 (7,200)	
API (Specific gravity)			75 (0.65)
Benzene, vol%			2.0
Molecular Weight			70
RON			82
MON			79
Heavy Naphtha (C <sub>7</sub> -350°F)	15.8	56.1 (11,060)	
API (Specific gravity)			52 (0.768)
Sulphur, ppm			5
Aromatics, wt%			12
Molecular Weight			105
RON			62
MON			60
Kerosene (Jet Fuel) (350-550°F)	19.1	71.1 (13,250)	
API (Specific gravity)			42 (0.815)
Aromatics, wt%			17
Molecular Weight			160



Diesel Fuel (550-650°F)	31.6	122.8 (22,200)	
API (Specific gravity)			37 (0.83)
Aromatics, wt%			10
Molecular Weight			215
Cetane Index			56
Flash Point, °F			150
Unconverted Residue (600-850°F)	32.6	135.5 (22,800)	
API (Specific gravity)			26 <sup>a</sup> (0.898 <sup>a</sup> )
Hydrogen, wt%			13.5 <sup>a</sup>
Aromatics, wt%			17 <sup>a</sup>
Molecular Weight			350 <sup>a</sup>
<sup>a</sup> Estimated.			

The combined total hydrogen content of the products is about 25% greater than the hydrogen content of the feed. Most of hydrogen gain is attributed to aromatic saturation. Only about 8% of the hydrogen goes to H<sub>2</sub>S and ammonia. However a significantly higher portion of the hydrogen, probably about 25%, breaks down hydrocarbon molecules via the desulphurization and de-nitrification reactions. Aromatic saturation in hydrocracking is not necessarily the intended operation of the hydrocracking but rather a result of the molecular break down as is the de-sulphurization and de-nitrification. Nevertheless reducing aromatics and essentially eliminating sulphur and nitrogen fits the needs of the overall operation.

The temperature rise between the catalyst beds is controlled well under 50°F using cold recycle hydrogen. Minimizing the temperature distribution across the catalyst bed is mechanical design issue.

Reactor V-2 effluent gas at about 2,000 psig and 750°F undergoes heat recovery at E-1, preheating the feed and is followed by high-pressure hot separator V-2A at about 500°F. The objective of the hot separator is two fold:

1. Increase heat economy by allowing the heavy portion of conversion products, mostly unconverted gas oil and some diesel, to go directly to product fractionation.
2. Eliminate potential deposits of PNA (poly nuclear aromatics) in the downstream cooling train. The formation of PNA is one of the side reactions of hydrocracking; however for LVGO boiling below 900°F the PNA formation is minimal.

The temperature of V-2A is an important parameter in the operation and thus to an extent controls the heat recovery in the system. Overhead product from V-2A proceeds to E-2 preheating hydrocracked feed to the product fractionator. Water condensate (about 100 gpm) is introduced to after E-2 at about 350°F to avoid deposition of ammonium sulfide in the tubes and tube sheets of heat exchanger E-3 cooled by tempered water.

The heat of reaction (about 300 MM Btu/hr) and net absorbed heat added to the reactor loop by the fired heater H-1 (about 60 MM Btu/hr, 360 MM Btu/hr total) is removed mostly by E-3 with the balance removed by the fractionation system. As noted, in this particular project situation, we are proposing tempered water-cooling as opposed to common air-cooling. The tempered water loop will be loading the heat on cooling water system or preferably provide

heat energy to appropriate process users such as preheating the bitumen. Cooled mixed phase hydrogen rich gas, hydrocracked liquid products and water undergo phase separation in the high pressure, cold separator (V-3) at about 1,850 psig and 130°F.

Overhead hydrogen rich gas (5-6 molecular weight) proceeds to bulk H<sub>2</sub>S removal with 50 wt% MDEA (amine) solution. Lean MDEA is pumped from a central amine regeneration plant. An electrically driven centrifugal recycle compressor (7,000 KW; one +one spare) recycles the hydrogen rich gas to the reactor section. The spare recycle compressor, unlike in most other hydrocracking operations, was added because of the very critical nature of this operation and its impact on other units including the dependence of the steam cracker on feeds from the hydrocracker. Prior to hydrogen recycle, a small purge is drawn to keep the hydrogen partial pressure above 1,900 psig. Purge gas comprising of about 90% hydrogen is routed to PSA hydrogen recovery in the hydrogen-synthesis gas production section.

Liquid products from high-pressure cold separator V-3 (about 40,000 bpsd) is let down from 1,850 psig in V-3 to V-4, the low pressure cold separator, operating at 120 psig. Flash gas at 120 psig, comprising formerly dissolved H<sub>2</sub> and C<sub>1</sub>-C<sub>4</sub>s is routed as feed to the steam cracker. Sour water comprising of essentially all the ammonia and about 8% of the H<sub>2</sub>S in the loop proceeds to sour water stripping and subsequent routing to ammonia and sulphur recovery. The bottoms of the hot separator V-2A (about 40,000 bpsd), mostly unconverted gas oil and diesel that contains some traces of PNA, is let down to low pressure in hot separator V-2B operating at about 120 psig. The bottoms of a V-2B, is routed to the V-5 splitter fractionation zone as shown. A very small amount of residual vapor is routed to the overhead of the splitter V-5.

Flashed liquid from the low pressure cold separator V-4 at about 130°F undergoes re-heating at exchanger E-2 and proceeds to H-2, the fractionator/splitter furnace. The feed to the furnace is being flashed at 750°F with a firing duty of about 350 MM Btu/hr. Saturated steam at 300 psig and slightly superheated steam at 50 psig is generated from the 900°F flue gas in the heater while cooling the flue gas to 400°F. Low pressure superheated steam is used for stripping the fuel products in fractionation.

### **Product Fractionation Section**

Flashed, mixed phase feed at 750°F enters the flash zone of the fractionator V-5 operating at about 10 psig overhead pressure and about 25 psig at the bottom. This tower is about 21'-0" ID by 100'-0" TT with about sixty (60 trays) plus the diesel side stripper V-9 and kerosene side stripper V-10. Naphtha light end is the overhead product. The diesel and kerosene strippers are also re-boiled by heat recovered from the unconverted gas oil from the bottom of V-5.

The overhead naphtha product containing some residual light ends and steam is condensed in condenser E-5 using tempered water. A portion of the overhead naphtha is refluxed to the column; the balance proceeds to naphtha splitter V-11. The light ends are separated in the reflux drum V-6 and are compressed to 120 psig by a wet gas screw compressor C-3. The light ends then merge with the flash gas from the low-pressure cold separator V-4 prior to being routed to the steam cracker. Light naphtha (7,200 bpsd) is routed to gasoline blending.

Heavy naphtha (11,060 bpsd) goes to trace sulphur removal followed by CCR catalytic reforming.

#### 4.1.4 Fluid Catalytic Cracking Feed Pretreatment

##### Overview

The issue of pretreating has gone through several evolutions. Initially a pressure of 1,650 psig was proposed; however in order to rule out the possible need of post treating the FCC gasoline, the pressure was elevated to 2,000 psig. Other information suggests that with the correct hydrotreating catalyst selection, a pressure of 1,200 psig could have been adequate. The following was used as a basis for presenting the concept:

1. Hydrogen compressor recycle: 1,950 psig
2. Hydrogen consumption attributed to HVGO: 950 scf/bbl
3. Hydrogen consumption attributed to HCGO: 1,150 scf/bbl
4. Total average chemical consumption of hydrogen: 1,082 scf/bbl
5. Estimated 99 % sulphur removal and 85% nitrogen removal at SOR
6. Estimated 98% sulphur removal and 75% nitrogen removal at EOR
7. Additional hydrogen losses to solution and purge: 4%.

The FCC pre-treater feed (496.5 tph; 75,250 bpsd) contains an estimated 5.15 wt% sulphur and 0.63 wt% nitrogen, including basic nitrogen, that originates from two sources:

1. Heavy vacuum gas oil (HVGO) (168.6 tph, 25,500 bpsd) with the following estimated assay (yet to be confirmed by lab tests): about 10 API gravity 900-1050°F comprising 4.5 wt% sulphur, 0.30 wt% nitrogen, 2 ppm metals, 0.4 wt% Conradson carbon residue and a hydrogen content of 10.65 wt%.
2. Heavy coker gas oil (HCGO), (328.9 tph 49,750 bpsd). The estimated assay (to be confirmed by pilot tests): 5.5 wt% sulphur, 0.80 wt% nitrogen, 3 ppm metals, 1.2% Conradson carbon residue and a hydrogen content 10.35 wt%.

After consuming 8.2 tph of hydrogen, the hydrotreater products comprise about 475 tph of hydrocarbons. It is estimated that some 2,500 bpsd of by-product naphtha is produced via side reaction hydrocracking during gas oil hydrotreating. It is estimated that this hydrocracked naphtha will be of lower octane (70 RON), low enough to justify diverting this naphtha to continuous catalytic reforming (CCR) for octane boosting. The net impact of this fractionation will increase the octane of FCC gasoline by 1.0 RON.

About 26.3 tph of H<sub>2</sub>S and 3.22 tph of ammonia are co-produced during hydrotreating. The ammonia is removed via water washing (about 300 gpm) to sour water stripping/ammonia recovery. The H<sub>2</sub>S is absorbed with MDEA solution and ultimately ends up in a sulphur recovery unit. The gravity is estimated at 19.5 API for the hydrotreated feed (75,300 bpsd) to the FCCU following pre-fractionation of hydrocracked naphtha. The estimated average hydrogen content of the feed to the gas oil hydrotreater is increased from about 10.45 wt% to about 12.20 wt% in the hydrotreated product and to 12.15 wt% in feed to the FCC.

Based on the above (which needs to be confirmed by more detailed studies), the following is the estimated yield based on the UOP characterization factor of 11.65: 12.15 wt% hydrogen. The hydrogen consumption, including solution and purge losses, is 85 MM scfd (8.5 tph). It is not known at this conceptual stage what percentage of the nitrogen is basic nitrogen, which could affect the catalyst activity. However, the experience of Colt Engineering for similar applications in Alberta suggests that using the highly elevated pressure of 2,000 psig will meet all process objectives and meeting sulphur specifications of the gasoline without the need of post treating. An operating pressure identical to hydrocracking pressure can provide additional synergism by allowing a common hydrogen header and common compression system.

### **FCC Feed Pre-Treating Process Description**

This FCC pretreater process (Figure AB-007) is based on a generic design as commonly applied for diesel hydrotreating. The main noticeable difference is the addition of a naphtha fractionator and the diverting the naphtha to catalytic reforming.

Heavy vacuum gas oil (HVGO) (25,500 bpsd) originating from the vacuum unit and heavy coker gas oil (HCGO) (49,250 bpsd) originating from the coking operation enter the Feed Surge Drum (V-1) typically at about 350°F. The mixed feed is pumped (P-1) at about 2,100 psig, preheated in exchangers E-1 and E-2 prior to mixing with recycle hydrogen and entering fuel gas fired heater H-1. The gas oil and hydrogen mixture at about 2,050 psig and 650°F enters hydrotreating reactors V-2 A&B where desulphurization, denitrification and some inadvertent hydrocracking takes place.

Mixed phase fluid at about 2,000 psig and 700°F proceeds to E-2 for heat recovery and undergoes phase separation in V-3. Heat is recovered from the overhead hydrogen rich gas in E-3, which preheats the recycle hydrogen. The rich gas is further cooled to near ambient temperature in E-4 and E-6. The cooled hydrogen recycle is amine scrubbed (V-7) with lean MDEA solution, which absorbs the bulk of the H<sub>2</sub>S. Water is injected prior to E-4, thus the ammonia with some H<sub>2</sub>S are removed prior to the MDEA absorber and diverted to ammonia recovery via two stage sour water stripping. Hydrogen recycle, substantially free of H<sub>2</sub>S, is compressed (C-1) and combines with makeup hydrogen from compressor C-2 and is recycled to the reactor heater H-1.

Liquid from high-pressure hot separator V-3 normally is let down to low pressure in hot separator V-4, flashing dissolved hydrogen and traces of light ends. Alternatively, the stream can be drawn as product. Water is injected into the V-4 overhead to avoid ammonium sulfide deposits. The light ends from V-4 are then cooled at E-7 and E-6 and pressure is let down in low-pressure cold separator V-5. Hydrogen rich fuel gas is released from V-5 to the fuel gas system. Sour water condensate from V-5 proceeds offsite for sour water stripping ammonia and sulphur recovery. Liquid naphtha produced by inadvertent hydrocracking and hydrotreated gas oil from low-pressure separator V-5 proceed to V-6 for stripping of about 2,500 bpsd of hydrocracked naphtha. The heat of fractionation is provided to V-5 via fired heater H-2. The stripper naphtha is routed to the naphtha reformer. The hydrotreated gas oil containing 500 ppm sulphur and 12.15 wt% hydrogen is routed to the FCC for gasoline production.

#### 4.1.5 Fluid Catalytic Cracking (FCC)

The fluid catalytic cracking unit (FCCU) shown in Figures AB-008 through AB-015 is a major conversion unit with the main objective of producing gasoline. Close to 50% of the complex's 100,000 bpsd gasoline output is directly attributed to the FCC. An additional 10% of the gasoline pool is derived from alkylation attributed to C<sub>4</sub> mixed products produced in FCC. The C<sub>3</sub> mixed product as well as the FCC off gas are significant contributors to the petrochemicals production of about 400 KT/Y during product recovery and conversion in the steam cracker. Some 10% of the diesel pool is attributed to severely hydrotreated FCC light cycle oil.

The design of the FCC was provided by the Shaw Group - Stone & Webster Engineering based on our yield estimate. The process technology of the FCC unit was developed by Axens-IFP of France.

The FCC and auxiliary processes consist of four major sections:

1. Feed hydrotreating to reduce sulphur and nitrogen and increase hydrogen (Section 4.1.5)
2. Catalytic reaction and catalyst regeneration by burning rejected carbon
3. Liquid product recovery of gasoline light cycle oil and heavy oil
4. Unsaturated gas plant recovering light ends, C<sub>1</sub>-C<sub>4</sub>.

As described in the FCC pretreater section (4.1.5), the hydrotreated FCC feedstock originates from 25,500 bpsd of heavy vacuum gas oil plus 49,750 bpsd of heavy coker gas oil.

#### FCC Yield

The following is the estimated yield from the FCC unit after fractionation of naphtha from hydrotreating. This yield data in tph (metric ton per hour) is based on interpolating data from other sources using similar feedstock.

	<u>Yield, wt% (vol%)</u>	<u>Flow, tph (bpsd)</u>	<u>Properties</u>
Hydrogen	0.10	0.475	
Methane	2.05	9.50	
Ethylene	1.03	4.75	
Ethane	1.24	5.70	
Propane	2.56	11.87 (3,530)	
Specific Gravity			0.508
Propylene	4.62	21.3 (6,190)	
Specific Gravity			0.52
C <sub>4</sub> 's	10.8	49.9 (11,800)	
Butylene	52		

Isobutane	35		
N-butane	13		
Gasoline (C <sub>5</sub> -430°F)	51.2 (62.5)	237.0 (47,120)	
API Gravity (density, lb/bbl)			55 (265.5)
LCO	14.9 (14.3)	70.2 (10,750)	
API Gravity (density, lb/bbl)			15 (338)
Slurry Oil	5.2	24.0 (3,320)	
API Gravity			-2
Coke	6.3	28.8	As burnt to CO <sub>2</sub>

Total C<sub>3</sub>+ liquid volume is 82,220 bpsd; the volume increase (swelling) is about 9.15 vol%. The estimated sulphur content of the FCC gasoline is 30 ppm. In addition, the FCC light ends contain a trace of CO as shown in the process description.

The FCC fractionator will accept about 5,365 bpsd of pyrolysis fuel oil produced during steam cracking, about an additional 975 bpsd of gasoline, 2,500 bpsd of a highly aromatic diesel stream and 1,890 bpsd of heavy slurry oil would be recovered. The combined slurry oil (5,210 bpsd) containing about 0.35 wt% sulphur will be filtered to remove traces of catalyst (say 1,000-2000 ppm) and will then proceed to emulsion system (30 wt% water at 160°F) to produce a fuel gas equivalent having 1,430 MM Btu/hr LHV. This fuel is considered as sufficiently low in sulphur and nitrogen content, thus no de-NO<sub>x</sub> nor is SO<sub>2</sub> removal is contemplated for downstream combustion by fuel oil or fuel gas consumers. The internal consumption of this highly aromatic heavy fuel oil within the facility is considered a significant element of synergism.

### **FCC Process Description**

The process description is based upon flow diagrams (AB-008 through AB-015, Appendix A.5) provided by Stone & Webster. The process conditions as well as the yield are discussed above and are based on our experience.

### **Reaction Section and Catalyst Regeneration**

Desulphurized, stabilized gas oil (75,300 bpsd at about 450°F) enters the bottom of reactor riser R-001 (Figure AB-008). The feed is atomized with live steam, injected and mixed with recycled regenerated catalyst from the regenerator R-002 at about 1,300°F. The combined catalyst, vaporized feed and steam at about 980°F proceeds through the riser where endothermic cracking reactions take place. The estimated yields of the cracking reaction are shown above. The riser overhead vapor product proceeds to a Stone & Webster proprietary high efficiency Riser Separation System (RSS). Reactor vapor from the RSS is directed to reactor internal cyclones (CY-001) for additional catalyst separation. The reactor mixed product proceeds to product recovery. To minimize product losses to the regenerator, spent catalyst containing about 0.8 wt% coke from the RSS and reactor cyclones is stripped of hydrocarbons in a Stone & Webster proprietary packed steam stripper in the annular section of the reactor and regenerated in R-002.

Catalyst regeneration is conducted by combustion with air at about 35 psig burning the coke produced in the reaction. The regenerator is operated in full burn condition. The resultant flue gas could contain some traces of CO, but within the limit of environmentally acceptable emission.

The combustion air, about, 200,000 scfm at 35 psig is provided by a 20,000 KW air compressor delivering the air at about 380°F. If needed during start up or at other times of unusual deficiency in heat, the combustion air could be further preheated at H-001.

Flue gas from catalyst regeneration undergoes entrained catalyst recovery in primary cyclone CY-003 and secondary cyclone CY-004. The flue gas at about 1,300°F proceeds to a tertiary cyclone (CY-007, see Figure AB-009) to orifice chamber D-002 for pressure reduction and to heat recovery steam generation at E-001, generating steam at 1,030 psig.

Because the sulphur content of the coke is low, about 0.3 wt%, no emission control would be required for the flue gas. Flue gas at about 400°F containing less than 200 vol ppm SO<sub>2</sub> and less than 500 ppm CO is released to the stack.

It is recognized that some 25,000 KW of electric power could be recovered by expansion of the regenerator flue gas. However, conversion of the heat energy to electric power would reduce the quantity of steam generated during the waste heat recovery. Therefore, after the reduction in power as would be regenerated in the steam cycle of 1030 psig, the added net power using a power recovery expander would be on the order of 8,000 KW. On this basis, and given the capital investment in power recovery and the incremental cost of electric power as generated in the complex, it was our judgmental decision that pure economics may not favor the power recovery option.

## **Products Recovery**

Reactor mixed product gas at about 950°F and 25 psig proceeds to the bottom of the main fractionator C-201 (Figure AB-010) for product recovery. An additional 5,365 bpsd of pyrolysis fuel oil from the steam cracker (containing 975 bpsd gasoline cut and 2,500 bpsd diesel cut) enters the middle part of the fractionator. The over 20'-0" ID fractionator has about 30 trays and/or packing and produces three major cuts:

- Bottom slurry oil (about -4 to -2 API and highly aromatic)
- Light cycle oil LCO (15-20 API and highly aromatic)
- Overhead product containing gasoline and lighter materials

The slurry oil proceeds from the main fractionator (C-201) to heat recovery (E-211, E-212, E-213, AC-203) including preheating the fresh feed to the reactor (E-211), through a filter to remove catalyst fines (not shown) and then proceeds to the emulsified fuel water system. The LCO product cut from C-201 proceeds to stripper C-202 for residual naphtha stripping by low-pressure steam. Overhead product is proceeding to unsaturated gas plant for gasoline and light end recovery.

Overhead vapor products from C-201 at about 10 psig and 300°F are cooled to near ambient temperature in AC-201 (Figure AB-011) and E-201. The majority of the naphtha and the steam injected to the system at various points is condensed and separated in V-202. A portion of the hydrocarbon condensate recycles as reflux to the main fractionator C-201. The net make is routed to absorber C-302 (Figure AB-012). Stripper C-301 strips out C<sub>2</sub> and lighter materials. The stripper bottom product proceeds to debutanizer C-304 where FCC gasoline is produced as the bottom product and C<sub>3</sub>/C<sub>4</sub> are separated as top products and amine treated to remove H<sub>2</sub>S (Figure AB-012).

The C<sub>3</sub>/C<sub>4</sub> product contains trace levels of sulphur species, mostly mercaptans. CS<sub>2</sub> and mercaptans are removed from the C<sub>3</sub>/C<sub>4</sub> by the extractive Merox (Mercaptan oxidation) process. The C<sub>3</sub>/C<sub>4</sub> is then depropanized (Figure AB-015). Depropanizer overhead (propane and propylene) are diverted to the steam cracker for propylene recovery. Propane is fractionated and fed to the steam cracker. The C<sub>4</sub> fraction is diverted to alkylation unit.

Overhead from V- 202 (Figure AB-011) is compressed by a two-stage, wet gas compressor K-301 (about 10,000 KW).

#### **4.1.6 Catalytic Reforming**

The option of catalytic reforming was referenced in the original proposal as a future option. However, during the preparation of the study it was realized that the octane of the entire gasoline blend fell short of the required octane of regular gasoline (87 (R+M)/2). The study mandate was to produce finished products to market specification. On this basis the octane had to be elevated in order to meet gasoline product octane specification. As discussed in the original proposal it was our judgment that catalytic reforming is the most economical method of achieving this goal. Further, it was decided that continuous catalytic reforming (CCR) as practiced in most recent reforming operations was the preferred method.

The reforming reaction as described in the attached drawing (Figure AB-016, Appendix A.5) is similar to the reformer scheme as shown on UOP's website ([www.uop.com](http://www.uop.com)) and text books. Axens-IFP has developed similar CCR technology and at this point we are not endorsing one technology over the other.

In the CCR reforming, the reaction is carried out in typically four catalytic reactors at a nominal pressure of 75 psig and 900°F. This is an endothermic reaction where inter-heaters, fired by fuel gas, provide the necessary thermal energy to drive the reaction. Waste heat from the heaters is recovered in form of 1,030 psig saturated steam. The recycle compressor, unlike the majority of CCR's, is driven by an electric motor.

A simplified way to illustrate the reforming reactions of naphtha is as follows:

1. Cyclization of n-paraffins to cycloparaffins. This is not very effective for n-paraffins and only 5% of n-paraffins are reacted.
2. Cyclization of iso-paraffins to cycloparaffins. This may achieve some 25% conversion of isoparaffins.



3. Dehydrogenation of cycloparaffins to aromatics. Principally benzene, toluene xylene and C<sub>9</sub> aromatics, and hydrogen are produced. The reformate, basically the main objective of the process yield of this reaction, is 84 wt% (81 vol%). The hydrogen yield is 3 wt%.
4. Inadvertent hydrocracking. Accompanied by molecular breakdown of paraffins to light hydrocarbons that produces methane, ethane, propane and butanes. The yield of this reaction is about 13 wt%.
5. Hydrodealkylation reactions. Under the category of hydrocracking we may also include hydrodealkylation reactions, for example, converting toluene to benzene and methane by reaction with hydrogen. The yield of this reaction is small, say under 2%, but it is a significant producer of benzene especially when benzene is undesired in the gasoline pool, which is the case here.

The naphtha feed to the CCR is in the boiling range of 180°F to 360°F where the lower boiling figure is a function of benzene considerations in the gasoline pool. Catalytic reforming is also the most common industrial method of producing benzene. Thus the benzene issue depends upon the overall product slate. For a fuel oriented refinery, although high in octane, benzene production is minimized by environmental limitations depending on type of gasoline. It is our assumption that the entire gasoline pool will meet the most stringent U.S. and Canadian benzene specifications and this is the basis of our conceptual design. Further, in most “normal” reformers the majority of the feeds are derived from atmospheric naphtha. In this particular situation, the majority (about 85% of the feed) is derived from hydrocracker naphtha and coker naphtha. Therefore it is expected to contain benzene and precursors of benzene such as cyclohexane and methyl-cyclopentane. Therefore, as discussed later, benzene concentrate is fractionated from the reformate and fed as an advantageous feed to the steam cracker.

The gasoline market specification for sulphur is 30 ppm. However due to catalytic reasons, the platinum catalyst used in reforming cannot tolerate more than 1 ppm sulphur. Therefore in most cases the feed to catalytic reforming, if fractionated of light ends (100-200°F), the C<sub>7+</sub> naphtha is hydrotreated to less than 1 ppm sulphur before catalytic reforming. The resultant light naphtha typically has 60-65 RON, which is boosted to about 80-85 RON via isomerization, prior to being blended into the gasoline pool. Normally the light naphtha has precursors of benzene but actually has very little benzene. In most California and Eastern Canada refineries, benzene concentrate from catalytic reforming is hydrotreated to cyclohexane. As a result, the gasoline pool is losing some octane. In other situations, benzene concentrate is sold to U.S. Gulf refineries presumably for benzene recovery by extraction.

### **Process Data**

The following are the feeds to the reforming section:

1. Heavy hydrocracked naphtha (11,060 bpsd, 56.1 tph) fractionated in the hydrocracker area. Light naphtha (about 7,200 bpsd, 31.0 tph) is routed to gasoline blending.

2. Full range hydrocracked naphtha (about 2,500 bpsd, 12.5 tph) from HVGO and HCGO feeds to FCC pretreating
3. Coker full range naphtha (18,600 bpsd, 93.0 tph) produced in the coker area.
4. Straight run heavy naphtha (4,500 bpsd, 24 tph) net make after diluents are recycled.

The hydrocracked naphtha contains less than 10 ppm of sulphur. From a pure sulphur consideration, this stream would be blended to gasoline however short of octane (probably 65 RON), high on benzene and the need for further sulphur removal prior to the reforming. The coker naphtha has some 1.6 wt% sulphur as opposed to say 200 ppm in “normal” naphtha. The coker naphtha also contains about 30 wt% olefins and 3.5 wt% diolefins and appreciable nitrogen (probably 1,000 ppm). The straight run naphtha could have about 3,000-4,000 ppm sulphur and about 500 ppm nitrogen.

Based on the above and subject to further evaluation in the detailed design phase, the following is the suggested processing:

- Coker naphtha and straight run naphtha will be mixed to form 23,300 bpsd (about 117.0 tph) of mid naphtha (55 API) containing 1.3 wt% sulphur and 24 wt% olefins.
- The above mixture will go through two stages of hydrotreating: (a) for diolefins conversion to olefins and (b) bulk olefins saturation and sulphur removal (99%). Hydrogen (15 MM scfd, 1.5 tph) at 700 psig is consumed to produce 23,550 bpsd of feed.
- Hydrotreated coker and straight run naphtha (116.6 tph) will be fractionated to light naphtha (100-180°F) and heavy naphtha (180°F+) producing an estimated 16,550 bpsd (85.1 tph) of 50 API heavy naphtha and 7,000 bpsd (31.5 tph) of light naphtha (about 76 API).
- The total 30,110 bpsd (153.7 tph) will go through a final hydrotreating at about 400 psig with 6 MM scfd of hydrogen (0.6 tph) to produce 30,250 bpsd (154.3 tph) of 52 API reformer feed containing some 1.5 vol% benzene.

The total light gasoline going to gasoline blending will be:

1. About 7,200 bpsd from hydrocracking (82 RON, 79 MON)
2. About 7,000 bpsd from coker naphtha (76 RON, 73 MON)

Total light gasoline (14,200 bpsd, 62.5 tph, 80 API, 79 RON) has a Reid vapor pressure (RVP) estimated to be 12.5 psi and contains 10 ppm of sulphur.

On the basis of the relatively high octane of the light naphtha, no isomerization is suggested. However, this substantial amount of light ends when added to the FCC light ends requires a careful examination of the Reid vapor pressure, which is estimated to be 7.20 psi. This RVP could be borderline for meeting the CARB gasoline specification. Under a worst case scenario, fractionating out about 3,000 bpsd of C<sub>5</sub> from the reformate and diverting it to the steam cracker (producing some 35 KT/Y ethylene) may be required. The removal of high RVP benzene concentrate is very synergistic with this concern. Needless to say, the overall

integration with the steam cracker provides a mechanism for controlling gasoline specifications.

### **Reforming Process Description**

Fractionated naphtha (153.7 tph, 30,110 bpsd) containing some 100 ppm sulphur is preheated by heat recovery (E-1, Figure AB-016) and a fired heater (H-1) to desulphurizing reactor conditions (about 400 psig and 600°F) after desulphurization and nitrogen removal. Heavy naphtha (154.3 tph, 30,250 bpsd) is fed to the reformer reactor (V-102) using hydrogen recycle of about 20,000 lb-mol/hr hydrogen contained as 86 mol%. The estimated inlet conditions of the first reactor are 900°F and 75 psig.

The pressure is decreasing due to hydraulic resistance and so is the entering temperature to the 2<sup>nd</sup>, 3<sup>rd</sup> and 4<sup>th</sup> stages. Outlet pressure from the fourth stage is about 40 psig. Net hydrogen is produced, compressed (C-2) for a dedicated PSA purification in the reforming area, producing pure hydrogen (40 MM scfd) and 5 psig residue gas rich in C<sub>2</sub>-C<sub>4</sub>. The residue gas is recompressed to 80 psig but routed to steam cracking rather than the normal routing to fuel gas. The reformate is stabilized (V-4) where some 6.35 tph of light ends are routed to the steam cracker. The usual LPG recovery is avoided in this case.

The liquid stabilized reformate product (about 24,500 bpsd, 100 RON) would normally be blended as a HOBC (high octane blending component) into the gasoline pool. However given this particular feed, we are expecting a minimum of 1,000 bpsd (about 4.1 vol %) of benzene in the reformate. Given the fact that FCC gasoline (about 47,000 bpsd) is expected to have about 0.8 vol% benzene, say 400 bpsd, and that the light gasoline has about 100 bpsd of benzene, then the total benzene content in gasoline pool may reach 1,500 bpsd or about 1.55 vol% of the total gasoline pool of 98,500 bpsd. This is unacceptable for the Canadian market or the reformulated gasoline market, which represents about 35% of the U.S. market.

Given the above, about 4,000 bpsd 25 vol% benzene (0.71 specific gravity) is fractionated from the reformate and diverted as feedstock to the steam cracker. This is further discussed in the process description of the steam cracking. This cut has an estimated 70 RON. By removing it from the reformate, the RON of the remaining reformate is elevated by 6 points to 106 and the elevation of the MON is even higher.

### **Reformer Yield**

The following product slate is produced by the reformer:

1. The main product, HOBC (111.55 tph, 20,280 bpsd, 38.6 API, 0.832 specific gravity), of 106 RON, is sent to gasoline blending.
2. Benzene concentrate (18.6 tph, 4,000 bpsd) containing 30 wt% benzene is sent to steam cracking to produce 37 KT/Y of ethylene.
3. LPG (about 6.35 tph) is 25 wt% propane, 25 wt% isobutene and 40 wt% n-butane also is steam cracking feed that produces 20 KT/Y of ethylene.
4. Hydrogen (4.7 tph, 47 MM scfd) is mixed with 14 vol% of light ends.

5. Light ends (13.6 tph) consisting of 1.3 tph methane, 4.0 tph ethane, 4.0 tph propane, 2.0 tph C<sub>4</sub>s, 1.0 tph C<sub>5</sub>s and 1.3 tph C<sub>6</sub>s too are feed to steam cracking to produce 53 KT/Y ethylene.

Hydrogen rich (86.3 vol %) fuel gas is compressed to 400 psig and proceeds to PSA hydrogen recovery at 400 psig. The estimated 85% hydrogen recovery will produce 40 MM scfd (4.0 tph) of pure hydrogen that is further compressed to 800 psig. About half the hydrogen is diverted to coker naphtha and CCR feed hydrotreating.

The PSA purge gas at about 5 psig is compressed to 80 psig and routed to steam cracking and ultimately converted into 55 KT/Y of ethylene. Total ethylene production from reformer sources is 92 KT/Y.

#### Utilities Consumption (CCR only)

1. Fuel gas to reformers inter-heater is 350 MM Btu/hr LHV firing duty.
2. Compression power for the recycle gas is 4,000 KW
3. Hydrogen net gas compression uses 7,000 KW
4. PSA purge gas compression to the steam cracker consumes 1,100 KW
5. 1030 psig saturated steam net export is 55,000 lb/hr
6. 130 psig steam for benzene fractionation is 80,000 lb/h

#### 4.1.7 Alkylation

Traditionally motor fuel alkylate is produced by reacting C<sub>3</sub>–C<sub>4</sub> olefins with isobutane to produce C<sub>7</sub>–C<sub>8</sub> iso paraffins. The C<sub>8</sub> branched paraffins are the most wanted motor fuel components with a strong preference for TMP (trimethylpentane). The common sources for C<sub>4</sub> olefins are FCC light ends and the C<sub>4</sub> cut from steam cracking. This is exactly the situation in this application. The C<sub>8</sub> alkylate is a perfect gasoline blending stock, especially to CARB gasoline, in terms of meeting high road octane, (R+M)/2, low RVP, 50% distillation temperature, benzene and all other common gasoline specifications. In general alkylate comprises 12% of the North American gasoline pool, but only 3% of the European gasoline pool. The tentative selection of a solid acid alkylation process over sulphuric acid alkylation is discussed in the process selection rationale.

The production capacity of the alkylation unit, 16,000 bpsd, is simply result of the estimated feeds and not an intended production target. So is the case with the isobutane makeup. For process flexibility, the nominal design of the alkylation unit is 18,000 bpsd.

The feed to the alkylation unit comprises of three sources:

1. FCC C<sub>4</sub>s
2. The steam cracking C<sub>4</sub> cut after butadiene extraction
3. Makeup isobutane from OBL.

The C<sub>4</sub> cut from the 75,000 bpsd FCC unit cracking hydrotreated feed has the estimated composition shown below. This estimated species distribution was prorated from another

application and represents an order of magnitude estimate. Total C<sub>4</sub> flow is 49.9 tph (11,800 bpsd).

	<b><u>tph</u></b>
Propylene	0.2
Propane	0.3
Isobutane	16.6
N-butane	6.4
Butylene-1	6.0
Butylene-2	10.6
Isobutylenes	9.7
Isopentane	0.3
Pentenes	0.2

The C<sub>4</sub> cut from steam cracker after butadiene extraction (10.1 tph) has the following estimated composition:

	<b><u>tph</u></b>
Propylene	0.1
Propane	0.1
Butene-1	2.1
Isobutylenes	5.9
Butene-2	1.4
Butadiene/C <sub>4</sub> acetylene	0.3
C <sub>5</sub>	0.2

The estimated makeup isobutane (22.2 tph, 6,230 bpsd) from OBL has the following composition:

	<b><u>tph</u></b>
Isobutane	21.1
Propane	0.3
N-butane	0.8

Purge to steam cracking is 7.6 tph:

	<b><u>tph</u></b>
N-butane.	7.20
Isobutane	0.4

Propane purge to steam cracking is 0.5 tph.

Alkylate production totals 73.6 tph or 15,950 bpsd.

Alkylate composition is estimated to be:

	<u>tph</u>	<u>%</u>
Trimethylpentanes (TMP)	57.0	77.5
Dimethylhexanes (DMH)	9.9	13.5
C <sub>5</sub> /C <sub>6</sub> /C <sub>7</sub>	5.1	7
C <sub>9</sub> <sup>+</sup>	1.5	2

The estimated octane rating of the total alkylate is 95.5 RON, 93.0 MON and 94.2 (R+M)/2.

### **Alkylation Process Description**

The solid acid alkylation system (Figure AB-017, Appendix A.5) is calculated to produce 16,000 bpsd (74 tph) of alkylate. The feed requires pretreatment to remove diolefins, sulphur, nitrogen and other compounds poisonous to the catalyst. These operations are generic and not particular to solid acid alkylation and are not shown in the flow diagram. Pretreated mixed liquid feed (FCC C<sub>4</sub>s and C<sub>4</sub> butadiene extract) at about 350 psig is combined with recycle isobutane at a typical recycle ratio of 12 to 15. The higher recycle shifts the yield toward the elevated octane.

However, octane needs to be optimized against the associated capital cost and utilities and ambient conditions. Makeup isobutane and warm recycle are refrigerated (E-104 E-105) before entering the bottom of the riser reactor (R-101). The reactant and suspended catalyst pass upward through the riser. External isobutene to olefin ratio of 13.9 combined with an average 70°F (21°C) reaction temperature control the yield toward maximum production of TMP. Isobutane also provides a heat sink for the heat of reaction about 620 Btu/lb olefin reacted. Over 99% of the olefins react with about 7% of the isobutane per pass. On the discharge end of the riser, the catalyst and alkylate rich fluid separate by gravity in the free board above the riser. The catalyst settles in the annular region around the riser.

A small portion of the catalyst, on the order of 1,000 lb/hr, is withdrawn from the annular section to be completely regenerated in a 30 minute cycle. The wet catalyst is withdrawn through lock hopper V-101. The bottom of the lock hopper discharges into regeneration vessel R-102. Hydrogen at 400°F vaporizes liquid and saturates C<sub>12</sub>-C<sub>13</sub> material. About 25% of the dissolved hydrogen (50 scf/bbl alkylate) is chemically consumed. Regenerated catalyst from V-102 is transported by the isobutane recycle stream to the riser (R-101).

### **Alkylation Product Recovery**

The primary product recovery occurs in the alkylate fractionator (C-201) commonly called an iso-stripper. The column is reboiled by 300 psig steam 420°F and side reboiler (E-202) using 50 psig steams 300°F. The C<sub>5</sub>-C<sub>9</sub> alkylate containing traces of C<sub>4</sub> is withdrawn as the bottom product and cooled by E-203 and E-204 prior to intermediate storage and gasoline blending. The fractionator produces isobutane rich product as a side draw that is charged to the deisobutanizer column (C-202) reboiled by 50 psig steam E-205. The bottom product is a 95% n-butane purge stream that is routed to steam cracking. The isobutene rich top product is chilled and condensed (E-207) prior to recycling. Fractionator overhead is condensed at E-208 and E-209. Hydrogen with some residual isobutane is sent to the fuel gas system.

#### 4.1.8 Diesel Hydrotreating

The diesel fuel produced in the complex (655 tph, 118,570 bpsd) is from the following sources:

- The hydrocracker diesel (122.8 tpd, 22,200 bpsd) 37 API is not hydrotreated.
- Atmospheric diesel (276 tph, 46,800 bpsd) of 27.5 API gravity is in the bitumen.
- Coker diesel (212 tph, 37,800 bpsd) of 35 API is produced in the delayed coker.
- LCO light cycle oil (70.2 tph, 10,750 bpsd) of 15 API comes from the FCCU.
- Pyrolysis fuel oil, 400°F+, (16.3 tph, 2,500 bpsd) of 15 API is produced by the steam cracker.

The estimated sulphur content and Cetane Index of the diesel stocks is as follows:

	<u>Sulphur, wt%</u>	<u>Cetane Index</u>
Atmospheric diesel (including 11 vol% kerosene)	2.7	41
Coker diesel	3.5	39
Light cycle oil	0.2	24
Pyrolysis fuel oil	100 ppm	22
Hydrocracker diesel	10 ppm	56

The hydrocracker diesel is a prime market ready product. All other diesel streams require deep hydrotreating to remove sulphur (total 15.0 tph) and nitrogen (0.6 tph) and to raise the cetane number by saturating aromatics. Break down of aromatic rings by additional hydroprocessing would even further improve the cetane index but is not considered at this point.

#### Hydrogen Consumption

Figure AB-018, Appendix A.5 shows the diesel hydrotreater flow sheet. Stage one hydrodesulphurization is conducted at 1,250 psig and 650°F. Sulphur is removed down to 10 ppm, which generates 15.9 tph of H<sub>2</sub>S; nitrogen removal produces 0.70 tph of ammonia (assumed 95%). The estimated hydrogen consumption totals 6.18 tph or 61.80 MM scfd, which is 631scf/bbl, distributed as follows:

	<u>tph</u>	<u>MM scfd</u>	<u>scf/bbl</u>
Atmospheric diesel	22.0	22	475
Coker diesel	2.55	25.5	675
Light cycle oil	1.13	11.3	1,050
Pyrolysis fuel oil	0.3	3.0	1,200

Feed to the second stage for aromatic saturation is 563.0 tph. Based on published data [NPR AM-95-40, table -5] for added hydrogen of 631 scf/bbl, the volumetric expansion (swelling) will be 2.77%; adjustment for sulphur content brings the swelling in the first stage of hydrotreating to 2.57%.

The diesel's molecular weight is estimated to be 200 and is estimated to contain 40 wt% aromatics. Estimating 4.0 mol of hydrogen per mol of saturated aromatic material and 90% aromatic saturation will result in the following performance: additional 90 MM scfd of net hydrogen consumption for aromatic saturation and a total of 157 MM scfd hydrogen, after allowing 5 MM scfd as solution and purge losses. Based on NPRA AM-95-40, the added swelling is 3.5% and the total swelling after two stages of hydrotreating is 6.2 vol%. The total hydrogen consumption for diesel hydrotreating is 1,600 scf/bbl and the Cetane Index of the diesel is estimated to be 46.0.

The hydrotreated diesel (103,870 bpsd or 572 tph) includes 5,100 bpsd of kerosene from the original bitumen and an additional estimated 2,400 bpsd of by-product kerosene produced by hydrocracking during the diesel hydrotreating process.

After kerosene (7,500 bpsd) fractionation, the total hydrotreated diesel product (96,370 bpsd, 532 tph) has 38.0 API gravity (0.8346 specific gravity). The total diesel product (38.0 API, 0.835 specific gravity, 48 Cetane Index), including hydrocracked diesel, is 654.8 tph (118,570 bpsd).

### **Diesel Hydrotreating Process Description**

The process configuration of the diesel hydrotreating and aromatic saturation unit is illustrated in Figure AB-018. Two identical trains of 50,000 bpsd are assumed. In the detail design phase, the option of a single 100,000 bpsd could be evaluated.

Mixed crude diesel from storage at a minimum temperature of 160°F or, more likely crude diesel from all sources at an average temperature of 300°F, enters the boundary limits of the diesel hydrotreating. As a conservative case, the heat balance for the exclusively 160°F feed case is used for estimating the capital and utilities requirements.

Charge pump P-101 pumps the crude diesel at 1,350 psig prior to entering filter M-101. The crude pressurized diesel feed is combined with about 60% of recycle hydrogen at mixing nozzle M-102. The balance of the hydrogen quenches reactor R-101. The mixed phase hydrogen-diesel stream is preheated by feed effluent exchanger E-101 to about 560°F before entering charge heater H-101, which is capable of firing either fuel oil emulsion or fuel gas. Partial heat is recovered from the flue gas by generating 300 and 50 psig saturated steam. The flue gas is released to the atmosphere at 360°F.

The charge heater elevates the temperature of the mixed phase to 650°F before entering hydrodesulphurization (HDS) reactor R-101 at 1250 psig. The HDS reactor has three beds. About 50% of the reaction occurs at the first bed, 35% in the second bed and balance of 15% in third bed. After the third bed, the sulphur and nitrogen contents are reduced to below 10 ppm. All the polyaromatics and a portion of the aromatics are saturated. Reactor effluent is cooled to 350°F by interchanging heat in E-102 before being charged to stripper C-101. H<sub>2</sub>S is stripped with makeup hydrogen from compressor K-101.

The flow is controlled by a by-pass, which provides a secondary means of controlling the inlet temperature to R-102, the hydrodearomatization (HDA) reactor. The sulphur content of the feed to R-102 must be below 10 ppm, not necessarily due to product specifications but



simply because the platinum catalyst in R-102 is very sensitive to sulphur species. Overhead from the stripper C-101 is sprayed with wash water through spray nozzle M-104 to dissolve any ammonium sulfide and perhaps traces of ammonium chloride that otherwise could solidify on the tube sheets and possibly block the flow. Wash water is decanted in HDS cold separator V-101 and along with sour water from V-104 is routed to the sour water stripper for ammonia and sulphur recovery.

The overhead from the HDS cold separator V-101 is routed to the H<sub>2</sub>S amine absorber. Using 35 wt% lean MDEA solution, the H<sub>2</sub>S content of the overhead is brought under 5 ppm as needed for the HDA reactor.

The inlet temperature to R-102 HDA reactor is 500°F or as low as 450°F at the start-of-run but not to exceed 550°F at the end-of-run. The HDA reactor comprises of four beds. The HDA reactor effluent, containing less than 4.0 wt% aromatics and less than 10 ppm sulphur, is cooled to about 375°F in E-103 prior to entering the hot separator V-102. The overhead from the hot separator is cooled by E-113 and E-105 before entering the cold separator V-103. The vapor exits this separator at 1,125 psig and is compressed to 1,305 psig in the makeup recycle compressor K-101. A purge gas from this separator keeps the hydrogen concentration above 95 vol%. The hydrogen loss from the purged plus the dissolved hydrogen loss represents about 4% of hydrogen makeup. The purge gas is routed to existing PSA units. A makeup/recycle reciprocating compressor is dedicated for each train plus a common spare is installed.

The bottom of the hot separator V-102 is the bulk of the dearomatized diesel. This diesel contains 7 vol% kerosene cut and about 0.5 vol % naphtha. The diesel is heated to about 400°F in E-108 and then to 460°F using 1,030 psig (550°F) steam (E-109). Overhead product of stabilizer C-103 (about 3,750 bpsd per train) with a maximum boiling range of 375°F is diverted to the kerosene pool. Light ends containing some hydrogen and traces of C<sub>1</sub>-C<sub>8</sub> hydrocarbons are compressed by K-102 to 80 psig and charged to the fuel gas system.

#### **4.1.9 Amine System Sour Water Stripping**

Bitumen (300,000 bpsd, 2,010 tph) containing a nominal 5.0 wt% sulphur and about 0.5 wt% nitrogen is desulphurized. Subsequent recovery as elemental sulphur or as marketable sulphur products is imperative in order to meet the fuel and petrochemicals specifications. The sulphur is removed by hydroprocessing, as discussed in other sections, with high pressure hydrogen reacting to form H<sub>2</sub>S. As a result of the hydrodesulphurization process, the bulk of the nitrogen is removed as well, producing ammonia. As noted, all the above issues are discussed in the sections dedicated to diesel hydrotreating, FCC feed pretreating, hydrocracking, naphtha hydrotreating and Rectisol acid gas removal.

#### **4.1.10 Low Grade Ammonia Recovery**

The total nitrogen in the feed is 8-10 tph (190-240 tpd) distributed as estimated below since no specific knowledge is available regarding the nitrogen species distribution, especially the basic nitrogen that can affect the FCC yield.

	<u>tph nitrogen</u>	<u>% of stream</u>
Nitrogen in 365 tph delayed coke	5.00 as ammonia	1.37
Nitrogen in coker light ends	0.90	1.1
Nitrogen in 475 tph feed to FCC pretreater	2.99	0.63
Nitrogen in 444 tph hydrocracker feed	0.53	1,200 ppm
Nitrogen in 488 tph feed to diesel hydrotreater	0.439	800 ppm
Nitrogen in 117 tph naphtha	<u>0.035</u>	300 ppm
Total accounted nitrogen	9.9	

The estimated ammonia production is attributed to the following sources:

	<u>tpd</u>
Coke gasification, 5% conversion	7.3
FCC feed pretreating, 85% conversion	70.6
Coker light ends, 100% recovery	26.2
Hydrocracker, 95% recovery	14.6
Diesel hydrotreating, 95% recovery	<u>12.1</u>
Total ammonia recovered	130.8

Sour water containing recoverable amounts of ammonia originates from the FCC feed pretreater, coker, hydrocracker, diesel hydrotreater and coke gasifier. The following is a brief description of the sour water stripping ammonia recovery. The ammonia recovery by Chevron's WWT process has been proven in number of applications with a typical ammonia recovery capacity mostly on the order of 20-25 tpd but including a large unit for Syncrude. Since the ammonia from the WWT has about 5 ppm H<sub>2</sub>S, it is not suitable for urea and nitric acid manufacture but could be an excellent candidate for other applications including ammonium sulfate production and de-NO<sub>x</sub> applications.

### **Ammonia Recovery Process Description**

This appears to be a good application for the WWT process licensed by Chevron-Texaco. The WWT process has been producing aqueous ammonia for the SO<sub>2</sub> removal system in the Syncrude facility at Ft. McMurray. The licensing department of Chevron is releasing very limited information on a non-confidential basis about the process, but did provide us with estimates of the utilities and capital investment. The following process description is speculated based on information published in Chevron's web site. Sour water, in our case about 1,500 gpm, is processed in two 1,000 gpm units. About 50% of the flow is attributed to the cokers. The sour water to the WWT process, containing about 1.5 wt% ammonia and about 3.0 wt% H<sub>2</sub>S, enters a high-pressure H<sub>2</sub>S selective stripper-fractionator operating with overhead reflux at about 100 psig. H<sub>2</sub>S with some traces of ammonia, say 100 ppmv, is released and sent to the sulphur recovery unit while the ammonia with some residual H<sub>2</sub>S remains in the bottom product. This bottom product undergoes ammonia stripping and re-absorption purification.

### 4.1.11 Sulphur Recovery

#### Process Overview

The following rich amine streams are the sources for 65% of the sulphur through MDEA amine regeneration. The most critical service is diesel hydrotreating where residual sulphur below 5 ppm in the hydrogen recycles is sought. Issues of olefins, acetylenes and diolefins deserve attention as well.

<u>Source of Rich Amine Stream</u>	<u>Nominal Pressure, psig</u>
Hydrocracker	2,000
FCC feed pretreater	2,000
Coker off gas	150
Diesel Hydrotreating	1,200
Naphtha hydrotreating	750
FCC C <sub>3</sub> /C <sub>4</sub> (LPG) treating	100

All the above sources except the LPG from FCC are co-producers of sour water comprising of ammonia and H<sub>2</sub>S. The H<sub>2</sub>S recovered from MDEA regeneration is almost pure but contains traces of CO<sub>2</sub>, hydrogen and methane. The coker light ends contain light olefins and some acetylenes and diolefins. Because of the very low sulphur specification of the hydrogen in aromatic saturation of the diesel hydrotreating, a separate MDEA system is dedicated to the diesel hydrotreating using very lean solution.

As shown later, ammonia and H<sub>2</sub>S are recovered from the sour water stripping. This nearly pure H<sub>2</sub>S with traces of CO<sub>2</sub> and ammonia is routed to sulphur recovery. The H<sub>2</sub>S from the Rectisol unit contains about 50 vol% CO<sub>2</sub> and traces of methanol. The combined H<sub>2</sub>S feed to the sulphur plant comprises of 80 vol% H<sub>2</sub>S and 20% CO<sub>2</sub>. The sulphur recovery attributed to the delayed coke as noted is attributed to the Rectisol process and described in detail in the Rectisol section.

#### Sulphur Species Distribution and Sulphur Yield

The sulphur distribution in the various bitumen cuts was not reported thus the estimated sulphur distribution is based upon a correlation with other crude oils and some verbal non-collaborated data. However, unlike the yields for the coker, the hydrocracker and the FCCU, this estimated sulphur yield is of secondary importance. For the sulphur balance we used 2,010 tph feed containing 4.94 wt% sulphur.

As shown below, the sulphur recovery is distributed among the following sources:

1. 65.5% is recovered via MDEA (amine) absorption regeneration
2. 26% is recovered via methanol absorption regeneration
3. 8.2% is recovered via water absorption and sour water stripping
4. 0.2% is emitted to atmosphere via combustion of FCC coke and slurry oil
5. 0.1% is emitted from ammonia scrubbing of sulphur plant tail gas.

The total calculated sulphur in feed is 99.29 tph (2,383 tpd) and the sulphur distribution is as follows:

	<u>tph sulphur</u>	<u>% of stream</u>
Sulphur rejected to 365 tph delayed coke	23.5	6.45
Sulphur in coker off gas	19.75	20
Sulphur in 93 tph coker naphtha	1.49	1.6
Estimated sulphur in 475 tpd gas oil to FCC	24.4	5.15
Estimated sulphur in 444 tpd hydrocracker feed	14.6	3.3
Estimated sulphur in 488 tpd diesel hydrotreater (excluding Light Cycle Oil)	15.2	3.1
Estimated sulphur in 24 tpd straight run naphtha	0.084	0.35
<b>Total accounted sulphur</b>	<b>99.0</b>	

### Sulphur Recovery Unit Process Description

The sulphur recovery is divided into two 65% sulphur recovery units (SRU), 1500 tpd with start-of-run sulphur conversion of 96.5% and an end-of-run conversion of 94.0%. Unlike the conventional tail gas treating, reaching 99.9% ultimate sulphur recovery, we elected to use tail gas incineration with fuel oil, where high sulphur fuel oil including emulsion of asphaltene is acceptable. The incineration at about 1,650°F will assure complete destruction of H<sub>2</sub>S. This incineration is followed by heat recovery that generates 1,030 psig saturated steam. Scrubbing with ammonia forms ammonium sulfite, which is subsequently oxidized to ammonium sulfate. The ultimate sulphur recovery is well over 99.9% and in the event that one of the sulphur plants is down, the second one can operate at full capacity using 600 tpd oxygen enrichment. This 600 tpd is only 7% of the capacity of ASU (air separation plant) during summer conditions. This excess capacity would likely exist based on the annual average, let alone using short-term supply obtained from liquid oxygen storage.

As shown in Figure AB-019, Appendix A.5, the combined H<sub>2</sub>S rich feed from three sources (the Rectisol unit, sour water stripper and MDEA regeneration) forms an 80 mol% stream at about 9.5 psig that is charged to the thermal reactor (6-1C-04). Combustion air (16,000 lb-mol/hr dry for both trains) using three (two + one spare) motor driven blowers (1,750 KW each) also enters the combustion chamber 6-1C-04. About one-third of the H<sub>2</sub>S is combusted to SO<sub>2</sub> and H<sub>2</sub>O. About 70% of the SO<sub>2</sub> formed reacts with the remaining H<sub>2</sub>S to form vapor phase elemental sulphur. Combustion gases undergo heat recovery in 6-1E-03, generating 500,000 lb/hr of 1,030 psig (550°F) steam.

Sulphur bearing gas from waste heat recovery at about 700°F enters the first sulphur condenser (6-E07A), condensing the bulk of the sulphur formed at 310°F while generating 50 psig steam. After liquid separation, the gas is reheated to 470°F in 6-1E04 by 1,030 psig steam and enters the first stage catalytic converter (6-C-04A). Converter exit gas at about 580°F flows to the second sulphur condenser (6-E07B) where additional 15% sulphur conversion occurs.

Similarly, the gas is reheated and flows serially through the remaining two catalytic converters (6-C-04B and 6-C-04C) and sulphur condensers (6-E07C and D). An additional

8% conversion occurs in the second catalytic converter and 3% more conversion occurs in the third catalytic converter for a total conversion of 96% at the start-of-run. The 4% unconverted sulphur is comprised of H<sub>2</sub>S, SO<sub>2</sub> and vapors of elemental sulphur.

The unconverted gas at 310°F (about 22,000 lb-mol/hr) containing mostly nitrogen and water vapor proceeds to incineration (6-1C-05) at about 1,650°F for complete elimination of H<sub>2</sub>S and sulphur vapor. Sulphur vapor is converted into SO<sub>2</sub> (about 1.1 mol%) and some 150 ppm of SO<sub>3</sub>. Incineration product gas is cooled to 400°F by generating 265,000 lb/hr of 1,030 psig steam and is sent to ammonia scrubbing.

#### **4.1.12 Ammonia Scrubbing, Oxidation To Ammonium Sulfate**

The proposed conceptual approach for removing unconverted sulphur from the sulphur plant as well as the power plant flue gas treater is similar to the operating facility of Syncrude in Ft. McMurray. Marsulex, which designed the Syncrude ammonia scrubber, has provided us relevant non-proprietary technical information. The proven wet scrubbing open spray tower design has been used for decades within the power industry and is the basis for the SO<sub>2</sub> removal system. High reliability factors and proven performance combined with the ability to utilize on-site generated by-product ammonia to produce a high value fertilizer product were the key factors in selecting this sulphur dioxide mitigation technology for both the power station boilers and to act as the tail gas unit for the sulphur recovery unit. We are told that based on North American Electric Reliability Council data of power industry proven technologies, the open spray tower style scrubbing system has a 99% on-line time factor, a higher on-line time factor than the boiler operations.

The scrubbing system is not expected to cause any significant downtime and, as noted, in the event that one sulphur plant is down the remaining plant can operate at full capacity using oxygen enrichment. The proposed tail gas ammonia scrubber can handle this scenario as well, which will result in about 20-25% higher SO<sub>2</sub> concentration. The Syncrude Ft. McMurray facility uses lower grade ammonia recovered from sour water, almost identical to the proposed situation in this case. As discussed earlier, the complex will generate approximately 130 tpd of lower grade ammonia from sour water stripping. This lower grade ammonia will be an excellent fit for ammonium sulfite/sulfate and de-NO<sub>x</sub> services.

In the Ammonium Sulfate Process (ASP), SO<sub>2</sub> scrubbing is accomplished in a spray tower absorber using a saturated solution of ammonium sulfate. Ammonia is fed into the absorber recirculation tank under pH control as the reagent for SO<sub>2</sub> absorption. Primary reaction products of ammonium sulfite/bisulfite are then converted to ammonium sulfate through forced oxidation with air. This reduces the potential for ammonia slip and enhances the mixing of the ammonia reagent in the circulating solution. The by-product ammonium sulfate crystallizes from the saturated absorber liquor, forming a suspension of ammonium sulfate. By maintaining a high recirculation of absorbing liquor and a low pH, ammonia escape in the flue gas is kept negligible and the plume visibility problem, which has been the stumbling block of previous ammonia scrubbing processes, is avoided.

A slightly sub-saturated stream of ammonium sulfate (approximately 40% dissolved solids) exits the absorbers to a common crystallizer. At this point, our proposed product is 40 wt% aqueous ammonium sulfate. However, if market grade product is desired, this product bleed

stream from the absorber is first dewatered in a hydroclone followed by a centrifuge to generate an ammonium sulfate product cake of approximately 98% solids. All the recovered solution is recycled to the absorber. The centrifuge cake is further processed in a granulator and/or dryer to make the final ammonium sulfate product containing approximately 0.2% moisture. The dried ammonium sulfate is then stored and shipped for sale.

### **Scrubbing System Description**

The scrubbing system comprises two scrubbers for the SRU (sulphur recovery unit) adequately sized for full load in the event that one SRU is shut down. The operating one is then enriched with oxygen.

## **4.2. Air Separation Industrial Gases Production**

### **4.2.1 Air Separation Unit (ASU)**

Production of oxygen by air separation is essentially a core process of the project since it is needed for hydrogen production by partial oxidation of the delayed coke. A result of oxygen production is a large amount of waste nitrogen containing about 1.5 vol% oxygen. In this case, pure (oxygen free) nitrogen is used for ammonia production and also as stripping gas for Rectisol acid gas removal. The ASU is also a major source of dry plant air and instrument air with local emergency back up in the facility.

Regardless of the ASU technology chosen, all technologies involve the following steps:

1. Air compression, typically to 90 psig in three stages
2. Compressed air drying and CO<sub>2</sub> removal, more commonly by PSA
3. Expansion of a portion of the air via a turbo-expander
4. Fractionation of liquefied air to produce oxygen and nitrogen
5. Cold recovery by re-vaporizing oxygen and nitrogen products.
6. Oxygen compression
7. In our case, producing pure nitrogen and nitrogen compression.

Each one of the potential licensors such as BOC-Linde AG, PraxAir, Air Products and Air Liquide is experienced in engineering, construction and operation of large ASUs. Differences in technology and sequencing of operation are beyond the scope of this study. The nominal oxygen production is 9,000 tpd (metric) divided into three identical 3,000 tpd trains. Oxygen is delivered at an estimated 98 vol% purity at 80 bars. About 2,700 tpd of nitrogen, containing less than 3 ppm oxygen, will be delivered at 60 bars to the nitrogen wash unit as a precursor to ammonia production. An additional 1,200 tpd of pure nitrogen will be delivered at 3 bars to be used as stripping gas in the Rectisol process. As indicated in the basis, the entire facility is driven by electric motors including the estimated 38,000 KW air compressors and 18,000 KW oxygen compressors. Applying the concept of liquid oxygen pumping is possible but will increase the size of the air compressors.

### 4.3. Gasification – Hydrogen and Synthesis Gas Production

This section encompasses production of hydrogen by partial oxidation of delayed coke. As shown, 90% of the coke is produced within the battery limits in delayed coking. The remaining 10% of the coke is imported from OBL such as from Petro-Canada's Edmonton Refinery. About one-third of the hydrogen from gasification sources will be dedicated for producing ammonia OBL or ISBL if an ammonia production unit were added. Additional hydrogen, about 90 MM scfd, is produced in the steam cracker and the catalytic reformer and is recovered separately in different PSA units at 400 psig. The overall complex system has about 20% of the total produced hydrogen exported OBL via pipeline.

#### 4.3.1 Delayed Coke Gasification

The gasification of delayed coke is one of the key attributes of the overall upgrading concept. Carbon is rejected from the bitumen (estimated at 324 tph) along with sulphur. Nitrogen plus about 3.6 wt% of residual hydrogen undergo a partial oxidation reaction with oxygen, which amounts to 40% of the theoretical oxygen required for full combustion of the coke. A portion of the converted carbon (about 20%) is oxidized to CO<sub>2</sub> and the energy as released drives the thermal decomposition of water, generating hydrogen and CO. The reaction products are hydrogen, CO, CO<sub>2</sub>, H<sub>2</sub>S, unconverted water vapor, unconverted carbon and traces of methane, COS, ammonia and HCN. As discussed later, after further conversion of 95% of the CO to hydrogen via the water gas shift reaction, the overall reaction could be simplified by the following equation:



The thermal decomposition of water along with carbon rejection provides for the hydrogen deficiency of the bitumen and raises the overall 9.9 wt% hydrogen content of the bitumen to hydrocarbon products of some 14 wt% hydrogen. Extra pure hydrogen for export as ammonia synthesis gas and pure hydrogen is made as well. The following is a good representative analysis of delayed coke derived from bitumen based on information from two independent sources:

Carbon, wt%	88.58
Hydrogen, wt%	3.60
Sulphur, wt%	6.45
Nitrogen, wt%	1.37
Nickel + Vanadium, ppmw	1689
VCM, wt%	8-12
Heating value, high (gross), Kcal/Kg	8571
Heating value, low (net), Kcal/Kg	8383
Moisture, wt%	12

#### Process Description

Figure AB-020, Appendix A.5, shows the process for the gasification of delayed coke. Delayed coke (8,760 metric ton per day, 365 tph on dry basis) with the above analysis is

conveyed by enclosed conveyor from the delayed coking area to the coke grinding area located inside the gasification battery limits. The grinding system uses wet mills, one mill per pair of gasifiers for a total of three mills. The grinding power is estimated at about 2,000 KW per mill or 6,000 KW total. Total heat released in grinding is about 20 MM Btu/hr, which raises the slurry temperature by about 25-30°F.

The fine coke slurry from the wet mill C-302 is routed to slurry holding tanks T-301 using conventional agitators. The slurry is maintained at about 120°F. The slurry combined volumetric flow (about 2,000 gpm) is pumped by appropriate pumps such as diaphragm pumps at about 1,150 psig (about 650 KW per pump, a total 2,000 KW) to the gasifiers' nozzles. The water added to the slurry system is salt free wastewater from the upgrader, mostly stripped sour water containing about 100 ppm ammonia, 10 ppm H<sub>2</sub>S and 200-500 ppm hydrocarbon material. The gasification of this water avoids the typical biological and other treatment otherwise required prior to disposing these wastewater effluents.

The coke slurry is mixed with oxygen at the discharge temperature of the oxygen compressor; we used 250°F for the heat balance in calculating the yield.

### **Gasifier Yield**

On generic basis gasifier yield is calculated by the following equations:

- Carbon balance
- Hydrogen balance
- Oxygen balance
- Water shift reaction approach to equilibrium
- Heat balance (including 1.5% heat leak from the refractory of the gasifiers).

The above five parameters will set the major gasifier yield once the gasification temperature is established based on operational experience, including carbon conversion per pass and oxygen to synthesis gas (CO + hydrogen) ratio. The following could be used for the fine tuning adjustment of the gasifier yield:

1. Approach to shift equilibrium. 50°F is used but it is not a critical number
2. Carbon conversion per pass. 90% is assumed but it is not a critical number
3. Approach to methane formation equilibrium. 1,000 ppm methane is used.
4. Sulphur balance COS to H<sub>2</sub>S ratio. We estimate 4% but it is not a critical number
5. Ammonia formation. We assume 5% nitrogen is converted to ammonia.
6. Establishing the traces of HCN and formic acid.

It was a judgmental decision given the fact that on site coal fired boilers are incorporated for steam power generation, unconverted carbon (soot) from gasification as described later would be conveyed to the fluidized bed boilers as a portion of the fuel mix. However, soot recycle to gasification is not ruled out for future consideration.



Based on all the above, the gasification yield is estimated for 65 bars-g (nominal 940 psig) and a gasification temperature of 2,600°F (1,425°C). Oxygen purity is assumed to be 98 vol% where the balance is mostly argon. It is worth noting that the impact of gasification pressure on the yield is very marginal. Directionally, increasing the gasification pressure should improve compression economics and increase the steam generation pressure after the quench. However, several limitations, including downstream pressure of the PSA hydrogen purification, led us to select the 65 bars pressure. The feed to the gasifiers comprises 365 tph (dry basis) of on-site generated delayed coke plus an assumed 38 tph of similar coke obtained from Petro-Canada's refinery. Total coke gasified is 403 tph. Slurry water (230 tph, 1,000 gpm), mostly oily wastewater containing ammonia, is charged with the coke. Oxygen input is 357 tph (8,570 mtpd).

### Gasification Yield

The total hot synthesis gas feed rate is 45,530 Kg-mol/hr (100,400 lb-mol/hr). The gasifier yields are:

	<u>Mol%</u>		<u>Mol%</u>
Carbon monoxide	45.0	Argon	0.05
Hydrogen	29.1	Nitrogen	0.50
Carbon dioxide	11.4	Ammonia	0.05
Water	11.7	Hydrogen sulfide	1.60
Methane	0.10	COS	0.05
		<b>Total</b>	<b>99.55</b>

About 62% of the slurry water decomposes in the gasification reaction. In addition, 39 tph of soot and 9 tph of ash are produced. A key parameter, the sum of carbon monoxide plus hydrogen totals 678 MM scfd or 74,400 lb-mol/hr. The  $O_2/(CO + H_2)$ , which equals 0.330, is a key parameter of the performance. The synthesis gas enters the bottom quench section at about 64 bars (925 psig). The quench equilibrium is calculated at 470°F using adiabatic saturation and assuming the recycle water is at 350°F as will be discussed in the shift gas cooling section below. The synthesis gas with some soot (unconverted carbon) has a water-to-gas molar ratio of 1.45.

Ash, fluxing agents and the majority of unconverted carbon are separated in the pressurized water pool of the quench section and periodically moved via a lock hopper V-302. As shown previously, the coke contains about 1,700 ppm nickel and vanadium, mostly vanadium. The vanadium oxide is formed in a reducing atmosphere as  $V_2O_3$  (unlike  $V_2O_5$  in an oxidizing boiler's atmosphere). The slagging temperature of  $V_2O_3$  is higher than the gasification temperature and thus could plug the quench ring. Adding boiler ash from the adjacent power plant or other source will alleviate this issue. The bulk of the unconverted carbon (say about 30-35 tph) along with the ash and fluxing agent, is removed via lock hopper V-302 as say a 20 wt% water slurry and undergoes dewatering in F-301. Solids-free water is recycled to the soot scrubber V-303.

Quenched synthesis gas at an estimated 470°F is routed to soot scrubber V-303, which contains proprietary internals and auxiliary units. Soot, the remaining unconverted carbon

(say 5-10 tph), forms about a 1.5-2.0 wt% carbon-in-water slurry, commonly called “grey water”. This water (about 1,500 gpm or 250 gpm per gasifier) is let down to about 30 psig at 280°F and flashed in a closed, proprietary settling device (F-301). Flashed vapors are routed to the sour water stripper in the upgrading section. Heavy soot slurry (about 35-40 wt%) settles out in the bottom. The clarified grey water is preheated to about 365°F or more by the soot slurry and pumped back to the soot scrubber V-303.

The heavy soot slurry from settler F-301 undergoes enclosed filtration (F-302). The solids are a portion of the fuel burned in the fluidized bed boilers. Clarified water at near ambient temperature recycles back to the soot scrubber V-303.

As discussed above, recycling of the soot slurry to the slurry system of the gasification is a more common practice and could be evaluated in the next design phase after finalizing the design of the boilers.

Overhead soot-free gas from the soot scrubber V-303 (estimated molar water-to-dry gas ratio, W/G, is 1.45) proceeds to the shift section for partial condensation of water vapor while generating steam at 300 psig. Increasing steam pressure from 300 psig to 350 psig is a trade off that needs further evaluation. The total chemical water consumption through reacting with coke is 341,000 lb/hr.

#### **4.3.2 Shift Reaction And Gas Cooling**

The shift reaction can be summarized as follows:

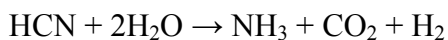
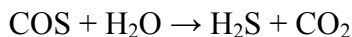
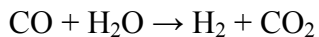

The first two reactions are exothermic and equilibrium limited.

Two forms of shift catalyst are known to exist: sweet shift and sour shift. Since the sour shift catalyst requires sulfiding, the presence of water vapor and H<sub>2</sub>S presents process synergism. On this basis, a sour shift catalyst was selected.

Ultimately, the shift reaction produces about 72,000 lb-mol/hr (655 MM scfd) of crude hydrogen. The crude hydrogen contains about 55 vol% hydrogen along with 42 vol% CO<sub>2</sub>, 2 vol% CO, 1.3 vol% H<sub>2</sub>S and 50 ppm of COS. Gas purification and hydrogen concentration to 99.9 vol% are the downstream process objectives.

#### **Sour Shift Process Description**

The shifting and cooling of the quenched gas from the coke gasification process is shown in Figure AB-021, Appendix A.5. The shift reaction is conducted in three parallel units due to size limitations. Quenched saturated synthesis gas (217,190 lb-mol/hr) containing about 59 mol% water vapor (2,313,000 lb/hr) and 88,650 lb-mol/hr dry gas at 910 psig, 470°F is

cooled to 450°F and 900 psig in 4-1E-04, releasing 585 MM Btu/hr. About 718,000 lb/hr of water is condensed prior to the shift reaction while generating 615,000 lb/hr of 300 psig saturated steam.

Using a steam-to-dry gas ratio of about 1.45, in the shift converter and avoiding 300 psig steam generation, as practiced in many locations for shift reaction, is an expensive overkill. Indeed it would result in increased CO conversion from about 95% as in the proposed case to about 97.3%, but would reduce steam economy by shifting the heat rejection from 300 psig steam before the shift to the 130 psig steam level after the shift. This would also increase the gas volume to the shift converter by 22%.

The synthesis gas, after partial condensation of water, is brought to a steam-to-dry gas ratio of 1.0 at 450°F (4-1E-04) prior to being reheated to about 500°F (4-1E-01) and entering the first sour shift reactor (4-1C-01). About 80% CO conversion occurs and this exothermic reaction forms shifted gas at about 830°F. This shifted gas is cooled (4-1E-02) by generating saturated steam at 1,030 psig and preheating boiler feed water (4-1E-03). The shift gas then preheats the feed gas to the first shift reactor from 450°F. About 648,700 lb/hr (36,040 mol/hr) of steam reacts with CO. Shifted gas at 470°F proceeds to the second stage shift reactor (4-1C-02) where an additional 15% conversion of CO to hydrogen occurs, chemically consuming 121,600 lb/hr of water vapor. The total CO conversion is 95% at about 535°F and the total chemical consumption of water in shift conversion is 770,300 lb/hr.

The shifted gas (178,360 lb-mol/hr) containing about 26 vol% (830,430 lb/hr) water vapor is cooled first to 400°F in exchanger 4-1E-05, generating 210,000 lb/hr of 130 psig steam. The gas is further cooled in exchanger 4-1E-06, generating 650,000 lb/hr of 50 psig steam. After separation of water at 330°F (4-1C-05), the balance of the cooling and condensing of 210,000 lb/hr of water is achieved by exchanging heat with makeup water in preheater 4-1E-07 and with cooling water (4-1E-08). The additional water condensate is separated in drum 4-1C-06 at 100°F. Total condensate is 827,400 lb/hr.

As noted, the total chemical consumption of water in the shift reaction is 770,000 lb/hr. The chemical water consumption in the gasification reaction is 340,000 lb/hr. Thus the total net water consumption for producing hydrogen in the combined gasification and shift is 1,110,000 lb/hr. The water feed to the gasification slurry is 550,000 lb/hr and 10,000 lb/hr is lost with the ash. Therefore a net makeup of 560,000 lb/hr is required. About 560,000 lb/hr of sour water is preheated to 290°F along with 210,000 lb/hr of water from cold separator and recycles to quench section of the gasification.

### **4.3.3 Rectisol Acid Gas Removal, Nitrogen Wash, PSA Hydrogen Purification**

The Rectisol process, using methanol as the physical solvent has been used in similar applications for many years. The Rectisol process, as licensed by either Linde AG or Lurgi Oil & Gas, employs methanol as a physical solvent for CO<sub>2</sub>, H<sub>2</sub>S and COS removal. Complete removal down to ppm levels of these species is very critical for ammonia production due to the ammonia synthesis catalyst. It is assumed that a portion of the CO<sub>2</sub> recovered by the Rectisol process will be used for urea synthesis. From the perspective of urea production, it is imperative that the CO<sub>2</sub> be totally free of sulphur species, i.e. less than 1 ppm, but 0.1 ppm would be better.

This by itself almost forced us to select the Rectisol process. However if the Selexol physical solvent is desired by the users, substantial changes in the upstream shift/gas cooling and added COS shift stages will be required. This would result in a very substantial increase in the required capital investment. For hydrogen dedicated to ammonia synthesis, about 33% of the crude hydrogen from shift is routed to an integrated Rectisol and Nitrogen Wash system as discussed later. For hydrogen dedicated to hydroprocessing, purification via PSA is achieved where the residue gas is recompressed for further hydrogen recovery in a second PSA system referred to as the purge PSA.

After the shift reaction, the ratio of CO<sub>2</sub> to H<sub>2</sub>S would be over thirty (30) and the resultant acid gas after bulk removal would contain only 3 vol% H<sub>2</sub>S and would not be a suitable concentration for conventional Claus sulphur plants without enrichment. However, in this case because the majority of the H<sub>2</sub>S generated in the MDEA unit is pure, the enrichment in the Rectisol process would not be as critical as in a stand alone sulphur recovery unit dedicated to Rectisol. The Rectisol process is very suitable for such enrichment because the selectivity of the methanol and the subsequent separation of CO<sub>2</sub> from H<sub>2</sub>S and COS. A H<sub>2</sub>S stream with some 50 mol% CO<sub>2</sub> is produced. A CO<sub>2</sub> stream with ppm levels of H<sub>2</sub>S and COS is produced as a second product. Needless to say, the third product is a synthesis gas totally free of H<sub>2</sub>S and COS and containing perhaps about 20 ppm CO<sub>2</sub> for the ammonia dedicated synthesis gas and about 200 ppm for the hydrogen dedicated synthesis gas.

One of the relative key advantages of the methanol solvent is the ability to co-absorb the COS along with the H<sub>2</sub>S unlike the Selexol solvent, which has lower relative affinity to COS. When producing fuel gas or even hydrogen for hydroprocessing, the COS issue is not applicable or is minimal at best. However for producing ammonia and even more so for urea, this is a more significant issue. A very small percentage of hydrogen and CO would dissolve in the methanol and eventually small portions (about 2,000 ppm) of them will show up in the CO<sub>2</sub> product. However CO and hydrogen would not affect the urea synthesis reaction and would eventually be purged from the urea synthesis loop to fuel gas.

Once Rectisol was selected for the ammonia synthesis gas, we decided to keep it for hydrogen service to maintain the synergism of only a single physical solvent and associated offsites. Because of size limitations, three parallel Rectisol trains are assumed, each with its own dedicated propylene refrigeration. One of the Rectisol trains is integrated with the Nitrogen Wash and its process configuration is slightly different than the Rectisol dedicated to hydrogen service.

### **Process Description - Hydrogen Service**

As shown in Figure AB-022, Appendix A.5, the feed gas (132,230 lb-mol/hr dry gas) containing 41.7 vol% CO<sub>2</sub>, 1.3 vol% H<sub>2</sub>S and 50 ppm COS at about 830 psig (57 bars) and 100°F (38°C) enters the boundary limits of the Rectisol unit from the sour shift's gas cooling area. The gas is saturated with water (about 160 lb-mol/hr) and contains traces of ammonia. After injection of methanol into the feed to prevent the formation of ice and hydrates, the gas is cooled in the first heat exchanger against purified product gas and cold tail gas. After separation of a condensed methanol-water mixture in a knock out vessel, the feed gas enters a wash tower (T-1) to be washed with sulphur free methanol.

In the upper part of the column, CO<sub>2</sub> is removed to 200 ppm for hydrogen service and 20 ppm for ammonia service. Cold lean methanol from the regeneration section is used for CO<sub>2</sub> removal. In the bottom section, H<sub>2</sub>S is removed to under 0.5 ppm. The heat of solution of CO<sub>2</sub> on absorption in methanol is partially removed by refrigeration using nominal -40°F (-40°C) propylene refrigeration. At the moment we estimate a dedicated refrigeration unit of 8,000 KW for each of the hydrogen trains and a 12,000 KW unit for the ammonia dedicated Rectisol train for a total 28,000 KW.

Since the solubility of H<sub>2</sub>S in methanol is much higher than the solubility of CO<sub>2</sub>, the majority of the CO<sub>2</sub> laden methanol is drawn out of the middle of the column. Only a small portion, about 10% of the methanol, is diverted to the H<sub>2</sub>S absorption section. The product gas from the top section undergoes cold recovery for hydrogen service and purified hydrogen about 96 mol% proceeds to PSA for final hydrogen purification, removing CO to the 50 ppm level as well as nitrogen and most of the argon.

The H<sub>2</sub>S loaded methanol containing some dissolved hydrogen is flashed at intermediate pressure (about 20 bars) flashing dissolved hydrogen along with small percentage of dissolved CO<sub>2</sub>. This minimizes hydrogen losses and further enriches the downstream H<sub>2</sub>S. The flash gas is recycled to the feed gas. The same procedure is used for the CO<sub>2</sub> loaded methanol: flashing dissolved hydrogen at about 20 bars along with a minimal amount of CO<sub>2</sub> and recycling the flashed hydrogen rich gas to the feed gas. The methanol is further successively flashed in T-6 (about 10 bars) and in T-07 (2 bars). The bulk (about 85 %) of the CO<sub>2</sub> is flashed. The volume that flashed at 10 bars is totally free of sulphur compounds including COS and is suitable for urea production after cold recovery.

Methanol with trace, ppm levels of H<sub>2</sub>S and COS is routed to stripping column T-2 for nitrogen stripping. The vent gas is substantially sulphur free but if not washed, substantial methanol losses would result. This methanol is recovered by water wash in T-05.

The H<sub>2</sub>S loaded methanol from the flash drum is let down to hot regenerator column T-3 where complete desorption of H<sub>2</sub>S, COS and residual CO<sub>2</sub> takes place. The H<sub>2</sub>S rich stream (about 50 mol%) is routed to the sulphur recovery unit in the upgrader area. A lean methanol bleed is routed to T-4 for fractionating the net water with traces of methanol.

#### **4.3.4 Ammonia Service/Nitrogen Wash**

The Rectisol unit for the ammonia service is integrated with the Nitrogen Wash and the scheme (not shown) is slightly different. The basic difference is the synthesis gas at about -67°F (-55°C) is entering the nitrogen wash. Treated synthesis gas, instead of undergoing cold recovery to 86°F (+30°C), is cooled by flashed methanol and flashed CO<sub>2</sub>. Therefore the refrigeration load is considerably higher (about an extra 4,000 KW) for the train dedicated to ammonia synthesis.

In the Nitrogen Wash unit, first traces of CO<sub>2</sub> and methanol are removed by a molecular sieve to avoid freezing in the downstream cryogenic section. About 10% of the stoichiometric nitrogen as needed for ammonia (about 250 tpd) is added in gaseous form at 60 bars. The expansion of the nitrogen creates a chilling effect adequate to liquefy the CO and portion of the nitrogen at -301°F (-185°C). The liquefied CO and nitrogen are vaporized

and refrigeration is recovered. All the CO, nitrogen, argon, and methane are washed away along with about 1.3% of the hydrogen and routed to low-pressure residue gas at about 15 psig (1 bar-g). The residue gas is compressed to 80 psig for the fuel gas system.

#### **4.3.5 PSA Hydrogen Purification**

The hydrogen dedicated for hydroprocessing and export is purified via three trains of pressure swing adsorption (PSA). This PSA system is in addition to the PSA hydrogen recovery unit in the steam cracker and to the PSA hydrogen recovery unit in the catalytic reforming unit.

As a general rule, maximum hydrogen recovery is achieved at about 25 to 30 bar while the residue gas is released at about 0.3 bars. The maximum PSA pressure, known to us is 60 bars and indeed above 55 bars hydrogen recovery is significantly reduced. It was a judgmental decision on our part that a PSA maximum pressure, of 55 bar-g (800 psig) is the set pressure for the upstream pressure profile, including 65 bars for gasification, 80 bars for oxygen compression etc. This is also a good pressure for operating the Nitrogen Wash unit.

No PSA schematic is shown; however, in our case a unit comprising 12 beds is conceived. Residue gas is exhausted at, 0.3 bar (5 psig). Hydrogen recovery of 80-81% is achieved as opposed to 86-87% recovery in a more optimal PSA pressure configuration. However we believe that on a global project basis our pressure selection represents near optimum conditions. Further the optimization of PSA is highly related to the fuel gas balance of the complex. We believe that the scheme we are proposing reflects this reality and that the PSA purge gas is recompressed for further hydrogen recovery.

At the moment our proposed scheme for hydrogen recovery is as follows:

1. PSA purge gas at 0.3 bars (5.5 molecular weight) is compressed by a rotary displacement compressor to about 5 bars (75 psig).
2. Pre-compressed gas at 5 bars is compressed to 55 bars via multi-stage reciprocating compressors.
3. Compressed gas at 55 bars proceeds to a single unit of purge PSA. Additional hydrogen recovery is achieved, reaching 95-96% ultimate hydrogen recovery.
4. Purge gas from purge PSA (20-22 molecular weight) is compressed by a rotary displacement or centrifugal compressor to 5 bars and routed to the fuel gas system. The PSA purge gas is combined with residue gas from the Nitrogen Wash.

The option of avoiding purge, PSA as proposed and recycling the purge gas to the second stage of the shift could be evaluated in detailed design. This will achieve high CO conversion depending on nitrogen purge as may become necessary. It should be noted that almost all the nitrogen is originated to the nitrogen content of the delayed coke and not to the ASU. In either case compression of PSA residue gas requires about 23,000 KW of compression, however the fuel gas balance in the complex made this operation unavoidable.

## 4.4. Olefins Production

### 4.4.1 Steam Cracking

The steam cracker is designed to produce 1,000 KT/Y of ethylene, assuming 8,400 hours per year of operation. Based on the current material balance, about 897 KT/Y of ethylene is attributed to advantageous feeds produced in the upgrader conversion section. The balance of the ethylene, 103 KT/Y, is attributed to feeds of opportunity from OBL. For material balance basis, we use an ethane: propane weight ratio of 65:35. Any future ratio or combination of C<sub>2</sub>-C<sub>4</sub> will be accommodated by the design for this additional ethylene production.

The propylene production is a by-product of the ethylene production, about 378 KT/Y of propylene is attributed to steam cracking and 175 KT/Y is attributed to FCC where the final fractionation is performed in steam cracking area. Propylene production totals 553 KT/Y. The ethylene production is attributed to the following 10 feed sources:

	<b><u>KT/Y Ethylene</u></b>
Hydrocracker unconverted gas oil	321
Coker light ends	254
Hydrocracker light ends	65
Alkylation unit butane purge	24
FCC off gas	78
FCC propane	44
Reformer LPG	20
Reformer fuel gas	53
Reformer benzene concentrate	37.5
Feed of opportunity	103
<b>Total</b>	<b>1000</b>

The feeds may contain some undesirable trace (ppm level) components such as arsine and mercury. Coker light ends contain 25% olefins and 2% C<sub>2</sub>-C<sub>4</sub> acetylene. The FCC off gas may contain traces of CO and NO<sub>x</sub>. Hydrocracker light ends and coker light ends also contain very significant quantities of methane and hydrogen in addition to the methane and hydrogen produced by steam cracking. All the above sources call for special design considerations to be addressed during the next phase of the study. Another unique feature of the steam cracker is full electric drive. Using only electric motors allows exporting high-pressure steam for power generation via a steam turbine using a re-superheat steam cycle. The steam power generation is integrated with an adjacent coal fired power generator.

A key design feature of the steam cracker is the ability to operate independently of the upgrader. In the event of shut down of the upgrader, the feed to the steam cracker will comprise liquid feed from storage and ethane/propane from OBL. In the event the cracker is shut down, the upgrader will continue to operate under the following scenario:

- Unconverted gas oil will go to available storage and once storage capacity is exhausted, will be exported OBL as a blend to synthetic crude.

- Coker light ends, FCC off gas and hydrocracker light ends will proceed to the fuel gas system and also as feed to the steam generators replacing coal.
- Under any of the above scenarios, the supply of electric power and boiler feed water from the power plant will continue uninterrupted.

Linde AG, Munich Germany, agreed to provide technical support for the olefins production during the preparation of the study. Stone & Webster, Houston Texas has reviewed the cost estimate after the completion of the conceptual configuration of the study.

## **Process Description**

The schematic of the steam cracking plant is shown in two figures. The cracking section is illustrated in Figure AB-023 while the compression and product recovery section's block diagram is Figure AB-024 in Appendix A.5.

### ***Cracking***

The hot section comprises nine furnaces, H-101 through H-109 (Figure AB-023). Three furnaces (H-101 to H-103) are dedicated to cracking of unconverted gas oil (about 23,000 bpsd; 26 API, 0.90 specific gravity) containing an estimated 13.5 wt% hydrogen (350 estimated molecular weight) and a boiling range of about 650-850°F and a steam-to-feed ratio of 0.75 is assumed. Five furnaces (H-105 to H-109) are dedicated to gas cracking including recycle ethane, propane and butane from all sources. Recycle hydrotreated C<sub>5</sub> from all sources (about 2,600 bpsd) as well as 4,000 bpsd benzene concentrate from CCR are mixed with the gas oil feed. The remaining furnace (H-104) is a common spare with dual capability for both gas and liquid, which also provides some added feedstock flexibility.

The cracking of C<sub>2</sub>-C<sub>4</sub> feed including recycle is very conventional. Gas feed at about 50 psig and 100°F is mixed with dilution steam available at about 120 psig, 400°F using a steam-to-dry feed weight ratio of about 0.35. The feed is preheated in the convection section of the cracking furnace by 2,000°F flue gas generated by combustion of fuel gas in the radiation cracking section. Cracked gas at about 12 psig and 1,525°F is produced in the radiant, cracking coil section. The cracked gas is cooled to about 400°F by a primary TLEs (transfer line exchangers), E-101 to E-109, producing steam at 1,850 psig, 975°F after superheating in the convection section. Then a secondary TLE (not shown) preheats 290°F boiler feed water to about 550°F. Cracked gas from the secondary TLE at about 400°F proceeds to the quench water system (V-102). In the quench water system, the cracked gas is cooled to nearly ambient temperature primarily by preheating recycle water from about 140°F to about 180°F followed by cooling water at 75°F. The warm water at about 180°F provides low-level heat for downstream warm fractionation.

The cracking of unconverted gas oil is not a very common operation, representing only small portion of global ethylene production. Preheating is done first to about 350°F in the downstream quench oil system as described, and then by staged evaporation and mixing of dilution steam. As indicated, the ultimate steam-to-hydrocarbon weight ratio is 0.75 or higher as required by operational considerations, including maximizing the run length between de-coking of the cracking coils. It is suggested for future evaluation that steam



superheating normally done in the convection section be avoided. The additional duty normally available for steam superheating then becomes available for generating additional saturated steam. Under this scenario saturated steam at about 630°F would be transferred to the super-heater in the dedicated coal fired power plant.

The cracking of liquid feeds and cooling their products, unlike the gas feeds, avoids the secondary transfer line exchanger (TLE) boiler feed water preheating. Cracked gas at about 830°F from the primary TLE proceeds to a quench oil system (V-101). One feature of the quench oil system is using heavy pyrolysis fuel oil recycle at about 450°F as a means of cooling the cracked gas while generating about 80% of the needed dilution steam at about 130 psig and preheating the liquid feed to the cracking furnace. The circulating quench oil absorbs some light hydrocarbon components that go on to gasoline fractionation (shown as C<sub>5</sub>-C<sub>8</sub> pyrolysis gasoline). The C<sub>9</sub>+ oil, normally known as pyrolysis fuel oil, is sent to the FCC fractionator for additional gasoline and diesel recovery. Overhead gas at the quench oil system (about 240°F) proceeds to a quench water system, the one used for the gas cracking operation.

### ***Cracked Gas Compression***

The nominal compression power of the five-stage cracked gas compressor (Figure AB-024) is 35,000 KW. The cracked gas is compressed to about 530 psig. Cracked gas at about 6 psig enters the compressor's first stage and proceeds through for five stages of compression. Compressed gas at 530 psig merges with largely desulphurized compressed gas from the upgrader and is caustic scrubbed (V-102) for CO<sub>2</sub> and trace H<sub>2</sub>S removal. The compression ratio is 2.0 in each stage and the temperature rise in each stage is limited to about 100°F reaching 185°F under summer conditions.

Two combined feeds enter the olefin plant at 520 psig, by-pass both the cracked gas compressor and the cracking furnaces and go straight to the caustic scrubber V-102:

1. FCC off gas at about 200 psig containing hydrogen, methane, ethylene, ethane and some propylene plus traces of CO depending on the mode of operation of the FCC
2. Coker light ends following sulphur and ammonia removal comprising C<sub>1</sub>-C<sub>4</sub> hydrocarbons including 25% olefins, some 2% acetylene, diolefins and traces of arsine and mercury.

The combined cracked gas leaves caustic scrubbing at about 520 psig and proceeds to a carbon bed for removal of arsine and mercury. Waste caustic, and wastewater from the cracker area are diverted to the upgrader area for wastewater treating.

Compressed gas at about 510 psig and 90°F proceeds through a carbon bed for arsine/mercury removal, a chilling stage, chilling the gas to about 60°F, followed by a water K. O. drum and then molecular sieve drying. During compression (C-101), inter-cooling with 75°F cooling water condenses a significant quantity of C<sub>3</sub>-C<sub>6</sub> hydrocarbons and some 2% of the C<sub>2</sub>s. The light portion of the C<sub>2</sub>-C<sub>6</sub> mostly C<sub>2</sub> is stripped and recycled to the cracked gas compressor. The heavier portion is diverted to the warm fractionation section for C<sub>3</sub>, C<sub>4</sub> and C<sub>5</sub>+ recovery.

### ***Cold Fractionation (Ethylene Recovery)***

The cracked gas proceeds through several stages of cold fractionation for ethylene recovery followed by warm fractionation for propylene and C<sub>4</sub> recovery (Figure AB-024). The most common fractionation system in terms of present market share uses a front-end demethanizer. Nova uses this scheme in their Sarnia operation and Dow uses this scheme in several plants. All major ethylene licensors have experience with this design sequence; however in recent years this method seems to be losing market share. The front-end demethanizer system places the acetylene reactor at the back end of the fractionation train where acetylene, equivalent to some 2% of ethylene production is hydrogenated to ethylene unless acetylene recovery is practiced. No acetylene recovery is envisioned for this project.

The second most popular scheme uses a front end deethanizer. Linde AG commonly uses this scheme for all feed applications. Others use it for gas cracking. Dow is known to operate several crackers with a front end deethanizer scheme.

Front-end depropanizer schemes along with other fractionation options are licensed by KBR and by Stone & Webster. Dow is known to use front-end depropanizing in some of their operations. Both front-end deethanizing and front-end depropanizing use a front-end acetylene reactor to hydrogenate acetylene to ethylene.

It is our opinion that the difference in economics among these schemes is not very large, probably under 3% in terms of investment in inside the boundary limit (ISBL) of the cracker as well as utilities. The difference is certainly within the accuracy of the study estimate. The final selection of fractionation scheme will likely to be influenced by three major factors:

1. Operational preference of the operator of the facility.
2. Multiple feed situations where C<sub>2</sub> to heavy liquids containing trace materials, including CO and NO<sub>x</sub> in the FCC off gas, and excessive amounts of methane and hydrogen are added to the cracked gas from refinery sources.
3. Actual capital cost and utilities, which would be determined by evaluation in the next phase for the unique feeds of factor 2 above.

In any of the above schemes, the product recovery section is a large consumer of propylene and ethylene refrigeration. Several options for refrigeration include open loop ethylene refrigeration compared to closed loops have been used. Again the bottom line difference among all these options is not very large and probably will depend upon the operational preference of the operator and the economic analysis for this particular project. Based on all the above considerations, the cold fractionation and acetylene removal system is shown on very generic basis where design details are to be decided in the next phase of the project development.

### ***Warm Fractionation (Propylene -C<sub>4</sub> Recovery)***

Warm fractionation (Figure AB-024) separates C<sub>3</sub> products from C<sub>4</sub>+ products and then separates a C<sub>4</sub> mixture from the C<sub>5</sub>+ product. A substantial quantity of C<sub>3</sub>s from FCC is also fractionated in this section. About 32% of the 553 KT/Y of propylene production is

attributed to the FCC. Two 210 trays, 15'-0" diameter fractionation columns are used. Design capacity of each is based on 300 KT/Y of propylene which would be nearly achieved if propane is used as an exclusive feed of opportunity and not the 65:35 ethylene: propane mixture. Fractionation heat at about 180°F is supplied by warm water from the quench water system and, if needed, tempered water from the upgrader. Using a heat pump is a possibility but not very likely. Fractionation in a single 21'-0" diameter column is theoretically possible but appears unlikely because the estimated 1,200 ton vessel would exceed the probable weight limitation for the Edmonton location.

The debutanizer will fractionate butadiene, C<sub>4</sub> olefins (butane-1, butene-2 and isobutylenes) and n-butane mostly attributed to uncracked coker light ends. The warm fractionation issues are not affected much by the cold fractionation issues discussed above.

The pyrolysis gasoline, C<sub>5</sub>-C<sub>8</sub>, is hydrotreated in two stages (Figure AB-024):

- Hydrotreating diolefins to olefins
- Hydrotreating olefins and traces of sulphur compounds

#### **4.4.2 Butadiene Extraction**

This process description is based on information provided by BASF in Ludwigshafen Germany. BASF is known to be one of the largest producers of butadiene as well as a major licensor of technology. The BASF-NMP Process is technology for the production high purity 1, 3-butadiene from crude C<sub>4</sub> cuts. This technology is successfully applied in more than 30 plants worldwide.

##### **Process Description**

The BASF solvent is based upon n-methylpyrrolidone (NMP) mixed with water. This solvent is non-toxic, non-corrosive and resistant to hydrolysis and thermal decomposition.

The following four basic process steps are employed see Figure AB-025:

1. Extractive Distillation: C<sub>4</sub> evaporation main wash rectifying after wash
2. Degassing: pre-degassing degassing compression
3. Distillation: propene (methyl acetylene) distillation butadiene distillation
4. Solvent Regeneration

The design for the extraction of 1, 3-butadiene calls for three extractive distillation columns, followed by two conventional distillation columns to purify the butadiene product.

##### **Extractive Distillation**

The evaporated crude C<sub>4</sub> cut is fed to the first column of the wash section, the main washer. Since the boiling points of the C<sub>4</sub> components are in a very narrow range and due to the potential formation of some azeotropes, it is necessary to use extractive solvent to separate the 1, 3-butadiene from the other, C<sub>4</sub> hydrocarbons. The addition of aqueous n-

methylpyrrolidone reduces the formation of azeotropes, thus achieving a substantial improvement in the relative volatilities of the hydrocarbons.

N-methylpyrrolidone (NMP) enters the tower below the solvent wash trays at the top. The function of these trays is to remove traces of NMP from the overhead vapour stream. The solvent absorbs the more soluble acetylenes and the butadiene in a counter-current flow. The top product of the main washer is raffinate 1, a mixture of butenes and butanes. The residual economical level of butadiene content in the raffinate is about 2,000 ppm but a substantially lower level could be achieved.

Rich NMP from the bottom of the column is fed to the top of the rectifier. This tower is built with an upper part (smaller diameter) and a lower part (larger diameter). The vapor phase with high butadiene content is found at that part of the tower where the diameter changes. It is fed to the after washer, where the C<sub>4</sub> acetylenes are removed by NMP, quite similar to the main washer.

The bottom of the rectifier is constructed in two sections. The first section is the rich solvent. The solvent is withdrawn and pumped through a set of heat exchangers, where it is heated using hot, lean NMP from the degasser bottom and flashed back to the second section of the rectifier bottom. The liquid product in this section is a partially stripped or a semi lean solvent. It is fed to the degasser, where all hydrocarbons are removed. The flash vapor rises through the lower section of the rectifier and forms part of the stripping vapor.

Crude butadiene is withdrawn from the top of the after washer. This stream consists of 1, 3-butadiene, 1, 2-butadiene, C<sub>5</sub> hydrocarbons, cis-2-butene and propine (methyl acetylene). The bottom product, rich NMP, is returned to the rectifier.

In reality the plant would be constructed with a divided wall column, which basically combines the rectifier and the after washer, resulting in a reduction of investment costs.

### **Distillation**

Crude butadiene is the feedstock for the propine column. In this tower the lighter component propine (methyl acetylene) is removed via conventional distillation. The bottom product is sent to the butadiene column, where pure butadiene is withdrawn from the top and the C<sub>5</sub>'s as well as the 1, 2-butadiene leave the bottom. Both columns may be combined in a divided wall column, resulting in a reduction of costs.

### **Degassing**

The semi-lean NMP coming from the rectifier is totally stripped in the degasser column. In this column the C<sub>4</sub> acetylenes leave the system as a side stream. They can be hydrogenated, used as fuel gas. The vapour leaving the top of the degasser is cooled in a separate cooling column or a heat exchanger, compressed and sent back to the rectifier.

## NMP Regeneration

A rate of about 0.2% of the total NMP is fed continuously to the stirred regeneration vessel. The vessel is heated by using low-pressure steam (3.5 bars) and is operated under vacuum conditions. Regenerated NMP in the gas phase is leaving this vessel, condensed in a water-cooled exchanger and collected in a drum. The non-condensable vapour leaving the condenser is washed with water to minimize solvent losses. The viscous residue consisting of polymers, inhibitors and NMP, is incinerated or used as fuel if applicable.

The typical product specification of a BASF Butadiene plant is as follows (All figures w/w):

1,3-butadiene	99.7%
Propadiene	<10 ppm
1,2-butadiene	<20 ppm
Total acetylenes	<40 ppm
C <sub>5</sub> hydrocarbons	<50 ppm
VCH	<50 ppm
NMP	<5 ppm

The raffinate composition is:

1, 3-butadiene	<2,000 ppm
NMP	<10 ppm

## Raffinate Fractionation

Extractive distillation of raffinate, separating raffinate into butanes and butenes is not very common because in normal crackers the residual butane is very low, under 3%. In this particular situation a substantial amount of n-butane originating from the coker light ends enters the cracker after the cracked gas compressor because of high olefins content. N-butane is recycled to cracking after further extractive distillation of the raffinate. The C<sub>4</sub> olefin from raffinate distillation is routed to alkylation unit in the upgrader.

The raffinate fractionation (Figure AB-026) is performed in two columns. In the first column, the butanes and the butenes are separated via extractive distillation. The solvent is the same one that is used in the butadiene extraction unit (NMP plus water). The butanes leave the column on top as a vapour stream. The butenes are dissolved in the solvent, leaving the column via the bottom. In the subsequent column the solvent is completely degassed. Butanes are obtained on top as a vapour stream and the degassed solvent on the bottom is recycled via a heat recovery system to the first column. Utility consumption strongly depends on the composition of the raffinate.

## Waste Disposal

A viscous residue is obtained from the solvent regenerator. It has to be diluted with water in order to obtain a low viscosity liquid at ambient temperatures. The amount of residue for a

plant with a capacity of 95 KT/Y butadiene is under approximately 60 Kg/day. The process wastewater will proceed to the wastewater system in the upgrader.

### Utility Consumption

The following consumption figures are expected:

Steam 20 bars (300 psig)	20 tph
Cooling water	1,650 M <sup>3</sup> /hr
Electricity	1,700 KW

Raffinate fractionation -Utilities Consumption:

Steam 20 bars	10 ton per hour
Cooling water, $\Delta T=5^{\circ}K$	1,650 M <sup>3</sup> /hr

Chemical Consumption:

	<b>Kg/t Butadiene</b>
NMP make-up	0.25
Silicon oil	0.02
NaNO <sub>2</sub> (100%)	0.01
TBC or comparable inhibitor	0.25

### 4.5. Offsites Definition

The following major offsites items have been identified as listed below. Four sections are used for offsite definition: Conversion, section (1); Hydrogen production including ASU, section (2); Steam cracker, section (3) and Steam/electric power generation (including emergency power), section (4).

1. Steam generation/BFW system, see section (4)
2. Fuel oil/fuel gas system global distribution
3. Cooling water system, separate for each section and ASU
4. Tempered water system, local distribution
5. Electrical substations, tie-in to the grid and global power distribution
6. Digital control systems use separate systems for each section
7. Plant air, nitrogen and instrument air are separate for each section
8. Tankage and blending system
9. Interconnecting piping
10. Site preparation, use 650 acres as a basis
11. Product custody transfer
12. Wastewater collection treatment and disposal
13. Miscellaneous chemical handling system, separate for each section

14. Plant buildings, roads, separate for each section
15. Flare and relief system, separate for each section
16. Safety and fire fighting, global system

The steam and power generation including boiler feed water system is part of section (4). All related items, including emergency package boiler, and emergency diesel generators with the exception of fire pumps are located in this area.

#### **4.5.1 Steam and Power Generation**

The fundamental design premise is the complex will be self sufficient in electric power (about 540 MW). After several iterations and discussions with the sponsors, it was decided that conventional combustion of solid fuel feed would be the prevailing concept. A combination of three fuels is considered:

1. Local coal such as Camrose sub-bituminous coal (8,600 Btu/lb)
2. Petroleum coke, excess coke, if any, or imported coke from OBL
3. Unconverted carbon from coke gasification

The concept of integrated gasification combined cycle (IGCC) was evaluated during the proposal stage and rejected. Nothing surfaced during the preparation of the study to suggest a reversal of this course. The decision of using direct combustion was influenced by the following perceptions:

1. IGCC is thought to result in a 35% higher capital investment at least for the specific integration scheme.
2. IGCC is less of a fit to the total integration concept.
3. The higher thermal efficiency of IGCC did not meet economic criteria even after including assumed tax relief.

Consideration was given to pulverized coal (PC) boilers and fluidized bed boilers. The initial perception was that the capital investment associated with fluidized bed boilers is somewhat higher; however, they are believed to have better fuel flexibility especially for coke and unconverted carbon from gasification. The largest operating fluidized boilers are two 250 MW units in Mississippi; a 300 MW unit is under construction in Jacksonville, Florida. The 270 MW power generation turbine happens to be the power generation capacity per unit. Due to steam imported from the upgrader, the actual size of the boilers (350 tph

steam at 1,800 psig, 1050°F) is approximately equivalent to 170 MW. Considering all the above, the fluidized bed boiler is in a conservative size range.

Typically fluidized bed boilers operate at about 1,700°F (925°C) using limestone as fluidizing agent. The limestone is thermally decomposed to CaO and CO<sub>2</sub>. The CaO reacts with SO<sub>2</sub> from flue gas to form CaSO<sub>3</sub>. The calcium sulfite along with ash is drawn from the combustion bed and disposed. Some 90-95% sulphur capture is achieved. The higher sulphur capture can be achieved by trim wet scrubbing with lime slurry or other alkaline material.

Our concept (Figure AB-027, Appendix A.5) represents a departure from this conventional fluidized bed approach. Instead of limestone, we propose to use sand and perhaps even contaminated soil if environmental credit can be obtained. No sulphur removal will occur in the bed. A single aqueous ammonia scrubber to produce ammonium sulfite will do the “trim” sulphur capture. Over 99% of the sulphur species will be captured. As discussed later, ammonium sulfite will be oxidized to ammonium sulfate. The granulation of the ammonium sulfate, is assumed to be conducted at OBL; however granulation within the complex should be considered. As discussed in the description of the sulphur plant, ammonia scrubbing is applied to the sulphur plant tail gas (after incineration) producing larger quantities of ammonium sulfite than the power plant.

The complex will generate some 130 tpd of lower grade ammonia from sour water stripping as discussed in another section of the report. This ammonia will contain about 5 ppm H<sub>2</sub>S and thus will not be suitable for urea or nitric acid production. However it is an excellent fit for ammonium sulfite/sulfate and deNO<sub>x</sub> services. Further a good portion of the investment in the de-NO<sub>x</sub> system in a conventional power plant is related to ammonia storage, transport and related infrastructure. This ammonia infrastructure already exists here and if needed additional ammonia is available near the prospective plant site.

The proposed design of the fluidized bed boilers offers flexibility to revert back to limestone as the fluidized solid agent for desulphurization in the conventional way. If the ammonia scrubbing sulfite oxidation system is shut down, conventional limestone scrubbing can be applied without interrupting the operation of the complex. This was also the basis of selecting a single ammonia scrubbing system.

## **Process Description**

The attached diagram (Figure AB-027) shows a generic fluidized bed power generation system. The facility is using three (two + one spare) 270 MW power generation systems. This heavy sparing is dictated by the high demand charge for unscheduled shutdown of a power generation unit. As a base case, the three boilers operate at 66% capacity; however operation at full capacity and 170 MW of power for export to the grid at a discounted rate is a possible business opportunity. The steam power system, aside from producing electricity and steam, provides boiler feed water to the process units in the upgrader and the steam cracker. The steam power system is also used to balance the steam demand for the entire complex via extraction and admission of steam from the main headers of the upgrader.



## Steam Cycle

Given the fact that the facility is totally electric, steam production and steam demand at various process units affect the selection of the steam cycle. The net steam balance of the facility to be provided by the steam power plant is as follows:

1. About 920,000 lb/hr (417 tph) 1800 psig-975 F from steam cracker
2. About 600,000 lb/hr of 1,030 psig saturated from multiple sources
3. About 1,030,000 lb/hr of 300 psig steam from multiple sources
4. About minus -500,000 lb/hr of 130 psig saturated steam
5. About 325,000 lb/hr of 50 psig saturated steam from multiple sources.

Based on the above it was decided that a single re-superheat cycle at 300 psig would represent the optimal level for this project case. Based on further analysis it was decided that re-superheating to 770°F and 270 psig would represent a reasonable choice for this case.

The higher steam level is 1,800 psig (1,035°F) combined of 1,400,000 lb/hr of 1,800 psig (1,050°F) steam from the boiler and 920,000 lb/hr 1,800 psig (975°F) steam from the steam cracker. Additional 600,000 lb/hr is admitted to the high pressure turbines. About 150,000 KW is generated in the high pressure turbine exhausting to 300 psig and 585°F. The exhaust steam (2,920,000 lb/hr after mixing with 1,030,000 lb/hr of excess 300 psig saturated steam from processes) is re-superheated producing 3,950,000 lb/hr of steam at 270 psig and 770°F. This re-superheated steam is expanded in low-pressure turbines exhausting to 1.1 psia, 105°F.

Excess process steam from the upgrader at 50 psig is used to preheat turbine condensate from 105°F to about 200°F. Heating and stripping the deaerator with 130 psig steam achieve the balance of the heating. About 950,000 lb/hr of steam at 130 psig is extracted from the low-pressure turbines, about 500,000 lb/hr to supplement the heat deficiency in the upgrader process area and 450,000 lb/hr for BFW preheating in the steam cycle. All this brings the power generation in the low-pressure turbine to 390,000 KW and total power generated to 540,000 KW.

## Steam-Power Cycle Description

The generic fluidized bed power plant is shown in Figure AB-027. Fluidizing sand or alternately contaminated soil from OBL is stored in silo F-1. As a back up as discussed above, conventional limestone can be used for fluidizing and removing SO<sub>2</sub>. About 2,000 tpd (metric) coal from OBL, and 900 tpd unconverted carbon from gasification are mixed in solid fuel silo F-2 and used as solid fuel for the boilers. The unique item about the steam cycle is the lower pressure 300 psig and high ratio of re-superheating duty to steam production duty, about 18% of the duty dedicated to re-superheating compared with more common 450 psig and 10% re-superheating duty in stand-alone power generation facilities. These departures from the conventional cycles are related to the excess steam from the upgrader being used for power generation.

A mixture of solid fuel and fluidizing gas enter the circulating bed fluidized bed boiler (B-1). Operating at about 1,700°F, it generates steam at 1,900 psig in the tubes and walls of the

cyclone as shown. This is a high velocity (about 10 ft/sec), entrained fluidized bed. The bulk of the fluidizing agent and unburned solid fuel is separated by a cyclone with additional steam generated in the wall of the cyclone. All saturated steam is routed to steam drum V-1. The captured solids of the cyclone fall to a second fluidized bed operating at a lower velocity (about 3 ft/sec) using secondary air for fluidized combustion while superheating steam to 1,800 psig at 1,050°F. This steam combines with 1,800 psig (975°F) steam from the cracker prior to entering high-pressure steam turbine G-1. Admission of 600,000 lb/hr of 1,030 saturated steam from the upgrader occurs at the appropriate admission point.

The future option of superheating this steam in a separate coil should be examined. The high-pressure turbine exhausts at about 300 psig and 585°F and combines with excess 1,030,000 lb/hr of 300 psig saturated steam from process area. Raising the intermediate steam pressure from 300 psig to 350 psig could be a matter of optimization. Flue gas from the re-superheater E-2 at about 1,000°F proceeds to economizer E-3 preheating boiler feed water from 290°F to about 500 F. and cooled to 650°F prior to entering a de-NO<sub>x</sub> system using vaporized aqueous solution of ammonia.

The 300 psig combined steam flow is re-superheated at E-2 and enters to the low-pressure turbine G-2 at 270 psig and 770°F. The low-pressure turbine has an extraction point for steam at 130 psig. This turbine exhausts to a vacuum of about 2.2" Hg, (105°F) prior to being condensed in E-5 using 75-95°F cooling water. The vacuum is generated by a 130 psig steam ejector system. Condensate at 105°F is pumped to deaerators operating at 45 psig using 130 psig stripping steam. The condensate is being preheated by 50 psig steam to about 200°F prior to entering the deaerator. Deaerated condensate is pumped back to 2,000 psig prior to reentering the steam power cycle. A portion of the condensate is pumped to the upgrader, the remainder to the steam cracker and other users.

## **4.5.2 Flue Gas Treating**

### **De-NO<sub>x</sub> System**

Low grade ammonia reduces NO<sub>x</sub> in F-4, the de-NO<sub>x</sub> system. An estimated NO<sub>x</sub> level of 500 ppm will be reduced to less than 50 ppm in a single stage and more likely 25 ppm in a two-stage de-NO<sub>x</sub> system. Flue gas from the re-superheater proceeds to economizer E-3, preheating boiler feed water to about 500°F, prior to entering the de-NO<sub>x</sub> system at about 650°F. NO<sub>x</sub>-free gas at about 650°F enters air pre-heater E-4 to preheat combustion air to about 450°F depending upon the ambient temperature.

### **Fly Ash and SO<sub>2</sub>**

Flue gas exits from air preheater at about 350°F enroute to the bag house (F-5) for residual dust removal and also for future carbon injection for mercury capture. Flue gas from the bag house enters a single ammonia scrubbing system for SO<sub>x</sub>. In the event the ammonia scrubbing system is down, limestone is injected to the fluidizing bed.

### **4.5.3 Cooling Water System**

About 90% of all heat and gas compression energy of the complex is ultimately rejected to the cooling water system, much of it directly and the balance through a closed loop tempered water cycle. The energy required by the complex is about 12.0% of the heat equivalent of the bitumen. The heat content of the bitumen is estimated at 17,500 Btu/lb LHV providing a total 77,500 MM Btu/hr of heat and combustion energy of 9,300 MM btu/hr. After allowing for a stack and fugitive heat loss of 10%, the energy absorbed by the complex is 8,370 MM Btu/hr. The energy absorbed by the endothermic reaction of steam cracking is 1,200 MM btu/hr. The endothermic reforming CCR heat of reaction is 200 MM Btu/hr. The exothermic reaction of hydrocracking is 300 MM Btu/hr, and the exothermic reaction in the sulphur plants is 670 MM btu/hr. The sensible heat of fuel products is about 100 MM btu/hr.

Thus the total heat load on the cooling water system is 8,040 MM btu/hr. Based on the above, the evaporative losses are 3,470 M<sup>3</sup>/hr and after allowing purge losses and heat losses from the cooling towers makeup water of 3,700 M<sup>3</sup>/hr, about 30 MM ton per year would be required. The different units in the complex have their own cooling tower systems. The temperature rises differ depending upon the cooling-heat rejection economics. Temperature rises could range from 20°F to 35°F depending on the application and a probable average of about 25°F. Major cooling water demands are:

1. About 180,000 gpm in section (1) conversion section, 12 cells
2. About 85,000 gpm in section (2) hydrogen-ammonia synthesis gas, 6 cells
3. About 35,000 gpm in section (3) steam cracking, 2 cells
4. About 280,000 gpm in section (4), power generation, 18 cells

### **4.5.4 Tempered Water System**

All tempered water heat is loaded on cooling water in the upgrader; no tempered water is used in hydrogen production, ASU or power generation. Only about 20% of the rejected heat is loaded on the tempered water. Had conventional air-cooling been used, the reduction in water consumption would be about 20%.

### **4.5.5 Electric Power Distribution**

Electric power, totaling 540 KW is distributed as follows:

1. About 134, 000 KW in section (1) conversion section
2. About 266,000 KW in section (2)
3. About 83,000 Kw in section (3) Ethylene and butadiene
4. About 31,000 KW in section (4) Power generation plant.
5. About 21,000 KW in generator and distribution losses.

#### **4.5.6 Plant Air**

Use one 100% capacity unit for each section with backup compressed air from the Air Separation Unit (ASU).

Each one of the major sections of the plant, upgrade, steam cracker, storage, etc., is equipped with a single 100% plant air compressor and dryer. Dry air from the ASU at 90 psig provides the back up instrument air and plant air system for all sections of the plant.

Nitrogen from the ASU provides all plant nitrogen supply requirements, as would be needed for variety of blanketing for product storage and, if necessary, dry stripping of fuel products. The service of the ASU as a source of plant air, plant nitrogen and also redundancy back up oxygen supply for the sulfur plants provides a significant element of synergism to the facility.

#### **4.5.7 Tankage**

##### **Feed Storage**

1. Six 400,000 bbl bitumen storage fixed roof tanks at 180°F
2. Six spheres (35" ID), 3,500 bbl each for isobutane at 100 psig
3. Four refrigerated spheres, 3,500 bbl each, for LPG 100 psig design pressure
4. Two fuel oil tanks, 10,000 bpsd each
5. Two 60,000 bbl river water tanks
6. Four 25,000 bbl fire water tanks
7. Two 5,000 bbl tanks for MDEA solution storage
8. Two covered coal piles @ 30 meters each

##### **Product Tanks**

1. Four 200,000 bbl fixed roof tanks for diesel storage
2. Four 150,000 bbl floating roof tanks for FCC gasoline storage
3. Two 50,000 bbl floating roof tanks for alkylate storage
4. Two 80,000 bbl tanks for reformat storage
5. Two 80,000 bbl floating roof tanks for kerosene storage
6. Four 25,000 bbl refrigerated tanks for propylene
7. Two 20,000 bbl refrigerated tanks for butadiene
8. Two 20,000 bbl tanks for hydrotreated pyrolysis gasoline
9. Two 10,000 ton pressurized under ground caverns for ethylene
10. Two 30,000 bbl (8,000 ton) storage pits for liquid sulphur
11. Two 20,000 bbl tanks for ammonium sulfate solution (40% solution)

## Intermediate Tankage

1. Two 120,000 bbl tanks for reduced crude (use 400°F design temperature)
2. Two 80,000 bbl tanks for reduced vacuum (use 450°F design temperature)
3. Two 120,000 bbl tanks for LVGO
4. Two 60,000 bbl tanks for HVGO (use 400 F design temperature)
5. Two 250,000 bbl floating roof tanks for diluent
6. Two 20,000 bbl tanks for untreated coker naphtha
7. Two 30,000 bbl tanks for coker diesel
8. Two 50,000 bbl tanks for coker gas oil
9. Two 10,000 ton coke storage pits
10. Two 100,000 bbl tanks for hydrocracker residue
11. Two 30,000 bbl tanks for hydrocracker heavy gasoline
12. Two 20,000 bbl tanks for hydrocracker light gasoline
13. Two 20,000 bbl tanks for hydrocracker kerosene
14. Two 40,000 bbl tanks for hydrocracker diesel
15. Two 100,000 bbl tanks for FCC gasoline
16. Two 30,000 bbl tanks for cycle oil
17. Two 20,000 bbl tanks for slurry oil
18. Two 20,000 bbl rundown tanks with vapor recovery for ethylene
19. Four 3,500 bbl storage sphere, 100 psig, for C<sub>4</sub>s
20. Four 3,500 bbl spheres for C<sub>3</sub> storage at 300 psig
21. Two 50,000 bbl tanks for coke slurry storage
22. Two 5,000 bbl tanks for methanol storage (Rectisol unit)
23. Two 100,000 bbl sour water tanks
24. Two 30,000 bbl tanks for rich MDEA solution
25. Two 30,000 bbl tanks for lean MDEA solution
26. Four 60,000 bbl demineralized water tanks
27. Two 10,000 bbl run off water tanks
28. Two 2,000 bbl spent caustic tanks

### 4.5.8 Fuel Oil/Fuel Gas System

The facility is a significant producer of fuel gas and low sulphur fuel oil; however, it is also a large consumer of heat energy. The low-level heat energy (up to about 520°F) is provided by steam. Any energy input above 520°F is provided by fuel gas and fuel oil. The fuel oil system is preliminarily selected as a water emulsion system comprising of 70 wt% liquid fuel and 30 wt% water at a typical temperature of 160°F. Because of the water content, the firing efficiency is degraded by about 3% compared with fuel gas. Total clean fuel generated ISBL is 5,602 MM Btu/hr. Additional 750 MM btu/hr is released by full combustion of rejected carbon in FCC unit. The following are the major producers of fuel within the complex:

1. Steam cracker including methane from the upgrader: 3,652 MM Btu/hr (860 Btu/scf LHV)

2. PSA purge gas from the hydrogen plant: 520 MM Btu/hr (227 Btu/scf LHV, rich in CO)
3. Emulsified slurry oil: 1,430 MM btu/hr.

Additional high sulphur fuel oil (about 700 bpsd, 168 MM Btu/hr) would be needed to bring the facility to a total fuel balance excluding the power plant. Needless to say the H<sub>2</sub>S produced is also a “fuel gas” and one third if it is combusted in the sulphur plant to generate 1,030 psig steam. An additional 2% of H<sub>2</sub>S provides heat energy in the incineration of the tail gas. Small organic waste streams from the butadiene unit and small quantities of fuel gas from products stabilizers are not taken into account.

#### 4.5.9 Gasoline Blending

All the following gasoline components are blended into a single gasoline stock (89.9 (R+M)/2, 0.50 vol% estimated benzene and 50% boiling point of 205°F) to be pipelined to market:

<u>Component</u>	<u>tph</u>	<u>bpsd</u>	<u>RON</u>	<u>MON</u>	<u>Estimated RVP, psi</u>
High Octane Blending Component	111.55	20,280	106	97	2.5
Light gasoline	62.5	14,200	79	76	12.5
FCC gasoline (54.7 API)	241.9	48,095	93	83	9.0
Alkylate	73.6	15,950	95.5	93	2.7
Total gasoline blend	489.55	98,525	93.7	86.2	7.10

#### 4.5.10 Major Fuel Consumers

With a total fuel consumption of 5,598 MM Btu/hr, LHV the facility is within fuel balance. Each of the duties is for the total service for both trains:

		<u>MM Btu/hr</u>	<u>No. of units</u>
1.	Cracking furnaces	2,367	9 furnaces
2.	Crude unit	650	2
3.	Vacuum unit	540	2
4.	Delayed coker	950	2
5.	Hydrocracker	400	1
6.	Catalytic reforming	350	1
7.	FCC feed hydrotreater	70	1
8.	Diesel hydrotreating	90	2
9.	Coker naphtha hydrotreating	11	1
10.	Naphtha hydrotreating reforming	20	1
11.	Incinerator of sulfur plant tail gas	300	2

The most preferred fuel for the incinerator of the sulphur plants would be low cost, high sulphur fuel because SO<sub>2</sub> removal via ammonia scrubbing is applied. All other users will consume low sulphur, emulsion fuel oil and fuel gas.

## **5.0. CAPITAL COST ESTIMATE**

The capital cost estimate is divided to three major categories:

- Inside battery limits (ISBL) refers primarily to the processing units
- Offsites includes steam and power generation, tankage and general infrastructure
- Off plot units include feeds or products pipelines.

The capital investment is defined as the instantaneous investment, i.e. “overnight construction”. All other costs such as escalation during construction, interest during construction, owner expenses and cost of financial closing fall under other accounts as shown in the economic analysis.

### **5.0.1 Inside Battery Limits (ISBL)**

The ISBL portion of a plant can be thought, as a boundary over which is imported raw materials, catalysts and chemicals, and utility supply streams. In a like manner, main products, by-products, and spent utility return streams are exported over this boundary. In this particular situation the steam-power generation plant is defined as an off site item although there is a reasonable probability that in the future, redundant capacity could be used for exporting electric power to the grid. It is a major plant facility, supporting the production units of the upgrader and the steam cracker.

ISBL investment includes the cost of the main processing blocks of the chemical plant necessary to manufacture fuel products and petrochemicals. It represents an “instantaneous” investment (i.e. no escalation) for a plant ordered from a contractor and built on a prepared site with a load bearing soil and all necessary drainage and surrounding infrastructure.

The ISBL investment includes the installed cost of the following major items:

- Vessels, heat exchangers, pumps and compressors, solids handling, housing of process units plus all installed spare equipment
- Process and utility pipes and supports within the major process areas
- Instruments, including computer control systems
- Electrical wires and hardware
- Foundations and structural supports
- Insulation and painting
- Process drainage and sewers
- Fire water pipes and monitors

The installed cost also includes all contractors and subcontractor costs, direct field cost, indirect field cost, contractor home office cost but excludes owner expenses, license fees and running royalties.

Outside battery limits (OSBL) investment includes the plant investment items that are required in addition to the main processing units within the battery limits. These OSBL Investments include auxiliary items that are necessary to the operation of the production unit, but perform in a supporting role rather than being directly involved in production. OSBL investments in general are proportionally prorated among several process units.

### **5.0.2 Outside Battery Limit (OSBL)**

Outside battery limit (OSBL) investment includes the following:

- Tankage for feeds, products, intermediate storage, dikes, and vapor recovery
- Steam generation, electric power generation and supply of boiler feed water to the facility
- Cooling water systems, cooling towers, circulation pumps and water pipeline from the North Saskatchewan River, including suction pumps
- Tempered water system including tankage, heat transfer to cooling water, piping and associated distribution
- Process water treatment systems and supply pumps
- Electrical supply, substation transformers and switchgears
- Loading and unloading and all appropriate custody transfer of products
- Auxiliary buildings, including all services, furnishings, and equipment:
  - Central control room including digital control systems
  - Maintenance
  - Stores warehouse
  - Laboratory
  - Garages/fire station
  - Change house/cafeteria
  - Medical/safety
  - Administration
- General utilities including plant air, instrument air, inert gas, stand-by electrical generator, fire water pumps
- Site development including roads and walkways, parking, railroad siding, electrical main substation, lighting, water supply, fuel supply, clearing and grading, drainage, fencing, sanitary and storm sewers, and communications
- Yard piping including lines for cooling water, process water, boiler feed water, fire water; fuel; plant air, instrument air, inert gas; collection aqueous wastes, relief piping, flares and process tie-ins to storage.

The most significant offsite items are the steam/power generation and the tankage. As discussed, a steam/power generation plant with power export capability is dedicated to the entire complex. Storing feeds, products and intermediate storage involves about 115 storage tanks for the entire complex. It is a judgmental decision that a dedicated plot area for storage



tanks for the entire facility would represent the most economical disposition of capital as long as operational flexibility and minimal dependence exist between the steam cracker and the upgrader. Based on the above, a block of tank farm was assumed and an estimate is made using material take offs based on the preliminary sizing of tanks as shown in the section dedicated to tankage, in most cases using a nominal 7 days of storage capacity. Just as a point of reference, in a “typical” U.S. Gulf Coast refinery, the investment associated with storage is the largest offsite investment and can be on the order of 15% of the capital investment associated with ISBL. The second most significant offsite item can be the marine terminal, which obviously is not applicable here. Site preparation and steam and water treating and electrical distribution are the next in order of investment magnitude.

### **5.0.3 Off Plot**

All off plots such as dedicated pipelines including the diluent systems, remote storage, remote marine terminals, rail lines and similar items are excluded from the cost of the project. The impact of these investments is reflected in the economic analysis as part of the cost of feedstocks and the netbacks for products.

### **5.0.4 Contractor Charges**

Contractor charges can be on the order of 15 to 25 percent of the combined installed ISBL and OSBL costs. These charges are included proportionately in the ISBL and OSBL investments. Contractor charges include the following major items:

- Detailed design, engineering and procurement, including process and offsites design, general engineering, equipment specifications, plant layout, drafting and cost engineering. It is anticipated that for this size of project this effort would be on the order of 8-9 % of total project cost.
- Administrative charges including, project management, engineering supervision, procurement, expediting, inspection, travel and living, home office construction expenses, general home office overhead. It is anticipated that cost of project management will be on the order of 4-5% of total project cost depending on subcontract engineering and construction.
- Contractor profit is likely to be a function of many factors, the most important being the project execution mode: LSTK (lump sum turn key) versus reimbursable Contract and, in either case, the liability of the contractors, especially liquidated damages. In our opinion the reimbursable open books project execution strategy is likely to result in lower capital investment. However, it would be less acceptable to financial institutions if a limited recourse project were the basis. The LSTK approach especially with liquidated damages would result in a significant PROJECT CONTINGENCY ALLOWANCE by the contractor.

A project contingency allowance is applied to the total of the above costs and takes into account unknown elements of the process technology and project in general, mostly construction related. For a well-defined process where the primary input came from engineering contractors on a basis of well known and frequently practiced technology, a contingency of 10 to 20 percent would be in line with the overall cost estimate especially for

ISBL units. However, in assessing the quality of the cost estimate and deciding the appropriate contingency to apply, reference was made to the Association for the Advancement of Cost Engineering (AACE) recommended practice for cost estimating accuracy.

The development of the cost estimate for this project was deliberately conservative, and based on consultation with various experts involved in recent projects involving process units similar to the ones involved in this project. As a result, the estimate is probably close to a Class IV quality, and could be assigned a 20 to 35% contingency level. However, recent project history has shown that a higher contingency level may be required in the current equipment cost and construction environment in Alberta. In addition, it was not possible for this estimate to meet all the formal documentation requirements of a Class IV estimate, so it has been designated as a Class V, and the 40% contingency applied accordingly.

### **5.0.5 Other Project Costs**

These costs are very site and project specific. They include startup-commissioning costs, miscellaneous owner's costs and other costs. They are described below:

1. Startup-Commissioning Costs
2. Extra operating manpower
3. Owners technical manpower
4. Startup services
5. Licensor representatives
6. Contract personnel
7. Equipment supplier/other vendor representatives
8. Operating manuals and training programs
9. Operating expenses to the extent that they do not result in saleable product.

### **5.0.6 Owner's Costs**

Below are typical owner's costs; not all are applicable to this project:

- Licensing/royalty for the basic process and engineering design package
- Long distance pipelines for raw materials and products (Not applicable here)
- Jetties, marine terminals, docks, etc. (Not applicable here)
- Land, rights of way, permits, surveys, and fees
- Piling, soil compaction/dewatering (Not known yet, allowance included)
- Sales, use, and other taxes
- Freight, insurance in transit and import duties
- Escalation/inflation to adjust from raw estimate based on instantaneous construction
- Interest on construction loans
- Construction worker's housing, canteen, and other infrastructure

- Field insurance
- Preliminary planning studies, HAZOP studies, environmental permitting
- Reviews, design, engineering, estimating, inspection, accounting, auditing
- Legal, construction management, travel and living expenses
- Initial charges of raw materials, catalysts, chemicals
- Initial stock of maintenance, laboratory, operating, and office supplies
- Transportation equipment, including railcars, trucks, containers, plant vehicles when not supplied by shippers
- Provisions for temporary shutdown expenses
- Owner's scope contingency allowance

### **5.0.7 Working Capital Components**

Working Capital typically includes the following items:

- Accounts receivable (products and by-products shipped but not paid by customer), less accounts payable, (feedstocks, catalysts, chemicals, received but not paid to supplier), assumed to be 30 days' sales revenue
- Cash on hand (short-term operating funds),
- Minor spare equipment and part inventory, percentage of ISBL capital
- Value of product and by-product inventories,
- Value of raw material inventory.

Inventory is a function of available storage and in transit times.

### **5.1. Method of Cost Estimate**

#### **5.1.1 Cost of ISBL**

All the ISBL cost items were derived from contractors, licensors, published information and private industry sources. For major ISBL items, an attempt was made to corroborate the cost data by at least one additional source's supporting information. However, many of the cost items, although very applicable to the bitumen, had to be adjusted to the specific configuration and location.

For example, the estimated \$450 MM US investment, before contingency, in delayed coking is attributed to 153,000 bpsd consisting of two trains of 80,000 bpsd cokers. A recent cost history of an 85,000 bpsd unit coking Maya crude on the U.S. Gulf Coast that went on stream some four years ago was available. It is thought that residue from Maya crude is similar to vacuum residue of the assumed bitumen. The capital cost for the coker was derived from the 85,000 bpsd Maya unit's actual cost history. Capacity was adjusted to 80,000 bpsd bitumen derived vacuum residue and was brought by cost escalation of 17% to December 2005 pricing.

It was judged by the contractor that given the envelope size in Canada (a 32'-0" ID coke drum), the 80,000 bpsd coker could be built in 4 drums and 2 heaters as opposed to 6 drums and 3 heaters in the U.S. unit that used 28 ft. drums. An appropriate adjustment of \$50 MM per train was made for this by the licensor. The coker in the proposed situation does not have LPG or other gas plant processing. Light ends are compressed within the boundary limit of the coker to 550 psig and also undergo H<sub>2</sub>S removal within the coker boundary limit. Desulphurized light ends is diverted as feed to the steam cracker. An additional adjustment was made to the investment due to avoidance of the gas processing section in the coker area. At the end, the estimated investment was corroborated by a very credible private industry source for another similar application.

Similar methods were used in other units. For example, the steam cracker uses a very unusual combination of feedstock and is driven by electric motors, not the common steam turbines. The steam cracker's \$485 MM ISBL estimate was broken down into major cost elements and was reviewed by Linde AG and by Stone & Webster against their recently awarded projects.

Shaw Group's Stone & Webster provided the process configuration for the FCCU and estimated its capital cost excluding contingency at \$205 MM ISBL. This is after making adjustments to some changes specific to the project, such as avoidance of internal power recovery and propylene fractionation. The \$195 MM cost estimate for the 70,000 bpsd hydrocracker was reviewed against a recent, single once-through 50,000 bpsd hydrocracker project and corroborated with a private source.

The cost of the sulphur recovery units (two 1,500 tpd) was compared against the cost of a large sulphur plant contract recently awarded to Worley Parsons for a Western Canada location.

### **5.1.2 Cost of Offsites (OSBL)**

In order to arrive at a  $\pm 25\%$  estimate for offsites, a plot plan, a more precise utilities definition and some major material take offs are required. Using a typical judgmental multiplier to arrive at the cost of offsites, say a typical 0.50 multiplier on ISBL cost, would result in  $\pm 50\%$  accuracy in estimating the offsites. On this basis we have decided to do some very preliminary definition of the offsites without a plot plan. The tankage would normally represent the largest offsite investment item, possibly some 15% of ISBL. On this basis all the tankage was defined and estimated by conventional material take off.

The power generation, the largest off site item, was also given a better definition and the estimate was broken into components. All other offsite units, about 40% of the total, were given a judgmental adjustment according to their common capital investment percentage in U.S. Gulf Coast refineries. After all these adjustments, we believe that the accuracy of the estimate of the offsites could be in the order of  $\pm 30-35\%$ . However, as noted above, a 40% contingency was applied to all project components, consistent with the definition of a Class V estimate.

## 5.2. Canadian Construction Adjustment

Data as received on the cost differential between Western Canada and Houston, Texas is somewhat conflicting, and was addressed by categorizing the major components of the cost estimate. The capital investments for the U.S. Gulf Coast combined ISBL and OSBL could be broken into the following major categories:

		<u>%</u>
1.	Major equipment and bulk	52.0
2.	Cost of transporting equipment	3.0
3.	Cost of Engineering	9.0
4.	Cost of start up	1.0
5.	Cost of construction	35.0
	<b>Total</b>	<b>100.0</b>

Building the upgrading–fuels-petrochemical complex in the Edmonton area will result in some elements of cost reduction due to the assumed larger envelope as discussed above, but also because of climatic advantages resulted from the lower ambient temperature. Ambient temperature especially effects compression and refrigeration in the ASU and the steam cracker and also results in an advantageous cooling water temperature. Some small negative adjustment especially for air compressors could apply to the estimated 670 meters elevation, yet to be confirmed by a specific site.

Construction in Alberta requires additional capital expenditure related to the winterization of process units but probably not structural steel specifications. However, many of these winterization issues are minimized by using a totally electricity driven facility that avoids steam turbines and the associated insulated condensate distribution systems. For this stage of the estimate, we assume that adjustment to structural steel will be near zero and that the added cost of process equipment related to climatic conditions, possibly less than 1.5%, is about balanced against the cost advantages attributed to climatic conditions.

It is assumed that the cost of major equipment and bulk materials, excluding sales tax, is about equal in both the U.S. Gulf and Edmonton areas, as they would be purchased from the same supply sources. Since the U.S. Gulf coast is accessible to barges and ocean transportation of items manufactured off shore, a 20% advantage on equipment and bulk transportation is assumed over Edmonton. On this basis the above 3.0% transportation item in U.S. Gulf will increase in Edmonton to 3.6% of project cost. The assumed 800-ton weight limit in the Edmonton area is a disadvantage over the more typical 1,500-ton weight limit in U.S. Gulf. For example, the lower weight limit may affect the cost of the hydrocracker reactor and the steam cracker's C<sub>3</sub> fractionator.

Because of the size of the project, it is assumed that the engineering effort will be a joint venture of a major U.S. contractor with 50% of the work by and Canadian contractors and subcontractors. Assuming the cost of engineering in Canada to be 10% below the U.S. cost will reduce the overall cost of engineering by 5% per man-hour. Furthermore it is also estimated that because of the Alberta location, an additional 5% engineering effort will be

required, especially for offsites. Based on the above, the total cost of engineering remains unchanged over the U.S. Gulf estimate.

Probably the most controversial item is the cost of construction. The “average” of two private industry sources suggested the additional construction cost in Edmonton is 30% above the U.S. Gulf cost assuming equal bearing soils. This is attributed to unionized labor and lower construction productivity related to climatic conditions. The estimated 30% added construction cost will increase the overall capital investment by 10.5 %. After considering all the above factors, the added cost in Edmonton is estimated to be 11.1 % plus any differential in sales tax on major equipment and bulks. This value was rounded to a 12% differential to account for unknown factors.

The availability of construction labor remains a key issue in assessing the overall differential cost. The effect of availability of construction labor and the availability of shop space during the execution of the project is unknown to us and any attempt to assess it would be speculative. In addition, phased construction could alleviate some of these concerns. It will reduce financial exposure. However, from a purely economical viewpoint, it is likely to result in a lower return on the investment and in less than optimal operation during the first phase of the project until the entire facility is on stream. It is a reasonable assumption that for the full program a peak construction work force of 6,000, and more likely 8,000, depending on modular construction, will be required. The engineering procurement effort could be on the order of 5 million manhours, probably a peak of over 1200 engineering procurement task workers, requiring several areas of technical expertise and project execution skills.

### **5.3. Capital Cost Breakdown**

This estimate, in million U.S. dollar units, is based upon Fourth Quarter 2005 U.S. Gulf Coast “overnight” construction. The capital cost history of the past year has been very volatile and attributed mostly to rapid escalation of price of crude oil and subsequent increase in related capital projects. A significant portion of any capital estimate, perhaps up to 20% in bitumen upgrading projects, could be related to specific engineering and construction specifications of the yet unknown partners that in many situations could exceed the objective needs of a given project based on common economics and risk analysis. The base cost estimate US Gulf Coast, excluding license fees, is based on stable markets with “reasonable” project specifications for producing the hydrocarbon products. The execution basis is a reimbursable project, employing competitive bidding processes for each major item and in most cases, selecting the most competitive offering by the vendors. The US Gulf Coast estimate also assumes a competitive construction labor market and non-unionized labor pool.

### 5.3.1 ISBL Conversion Section

		<u>Million U.S. \$</u>	<u>Comments</u>
1.	Crude flash drums heaters	70	Two 200,000 bpsd trains
2.	Vacuum Unit	90	Two 125,000 bpsd trains
3.	Cokers (two 80, 000 bpsd, 4 drums)	450	No light ends recovery
4.	Hydrocracker (70,000 bpsd)	195	70% conversion, single pass
5.	FCC Hydrotreater (75,000 bpsd)	115	85 MM scfd H <sub>2</sub>
6.	Diesel Hydrotreater (two 50, 000 bpsd)	225	Includes aromatic saturation
7.	FCCU (75,000 bpsd, no power recovery)	195	Excludes C <sub>3</sub> fractionation
8.	FCC LPG Merox unit (for sulphur)	10	30,000 bpsd of heavy gasoline
9.	Alkylation Unit (16,000 bpsd)	55	C <sub>4</sub> alkylation
10.	Catalytic Reformer (30,000 bpsd)	65	Excludes LPG recovery
11.	Reformer feed hydrotreater	30	Includes fractionation
12.	PSA Hydrogen Recovery from reformer	15	Include purge gas compression
13.	Benzene Concentrate Recovery	5	4,000 bpsd 25 vol% benzene
14.	MDEA regenerators (two 1,050 tpd H <sub>2</sub> S systems)	40	Excludes H <sub>2</sub> S absorbers separate for Diesel hydrotreater
15.	Claus Sulphur plants (two, 1,500 tpd)	90	96.5% sulphur recovery
16.	Incineration, SO <sub>2</sub> ammonia scrubbing	35	For sulphur plant tail gases
17.	Sour water- ammonia recovery	50	Two 1,000 gpm units, 65 tpd ammonia per train
18.	Coker/SR naphtha hydrotreater	30	Single unit, 24,000 bpsd
	Subtotal	<b>\$1,765</b>	
	Add 40% contingency	\$706	
	<b>Total Upgrading - ISBL U.S. Gulf Coast</b>	<b>\$2471 MM</b>	
		<b>US Gulf</b>	

### 5.3.2 ISBL Coke Gasification - Hydrogen/ammonia Synthesis Gas

		<u>Million U.S. \$</u>	<u>Comments</u>
1.	ASU + O <sub>2</sub> compressors, three 3,000 tpd	175	98 vol% at 1,160 psig
2.	Coke preparation and grinding	50	Use 3 grinding trains
3.	Gasification (6 gasifiers, 65 bars)	240	Design 2,000 tpd each
4.	Rectisol (3 trains)	215	Includes refrigeration
5.	Shift and gas cooling (3 trains)	90	Common start up system
6.	Nitrogen wash and CO <sub>2</sub> mol sieve	15	3,000 tpd ammonia
7.	Nitrogen compression	15	2,700 tpd
8.	PSA (three 150M scfd, 5 psig purge)	45	12 beds per train
9.	PSA purge gas compression	25	Screw plus three 50% reciprocating
10.	Purge PSA (5 psig purge)	10	
11.	Fuel gas compression two 35 MM scfd	10	5 psig to 80 psig screw
	Subtotal	<b>\$890</b>	
	Add 40% contingency	\$356	
	<b>Total Coke Gasification - hydrogen/syn gas</b>	<b>\$1,246 MM</b>	
		<b>US Gulf</b>	

### 5.3.3 ISBL Steam Cracker - 1,000 KT/Y Mixed Feeds

		<u>Million U.S. \$</u>	<u>Comments</u>
1.	Four cracking furnaces, heavy feed	75	
2.	Five cracking furnaces light feeds	80	
3.	Quench oil/water systems-dilution steam	35	Quench oil to liquid crackers
4.	Cracked gas compression	40	37 MW electric
5.	Caustic scrubber	10	At 520 psig
6.	Acetylene reactor	10	Either front or back end
7.	Refrigeration ethylene/propylene	55	Electric including heat pump
8.	Cold fractionation (Include dryer)	90	Regardless of sequence
9.	Warm fractionation (two C <sub>3</sub> columns)	45	Includes 35% of FCC C <sub>3</sub> s
10.	PSA hydrogen recovery	10	40 MM scfd hydrogen
11.	PSA purge gas compressor	5	
12.	Pyrolysis gas hydrotreater	20	6,000 bpsd
13.	Arsine removal bed	10	
	Subtotal	485	
	Butadiene extraction	40	Includes n-butane separation
	Sub total olefins	<b>\$525</b>	
	Add 40% contingency	\$210	
	<b>Total olefins</b>	<b>\$735 US Gulf</b>	
	<b>TOTAL ISBL Upgrader and Petrochemicals</b>	<b>\$4,452 US Gulf</b>	

### 5.3.4 Offsite Items

#### Steam & Power BFW

		<u>Million U.S. \$</u>	<u>Comments</u>
1.	Coal handling system/ash disposal	20	Includes ash pond
2.	Three mixed feed fluidized bed boilers, including re-superheaters, economizer and pre-heaters.	145	350 tph each; 1,800 psig, 1050°F; includes coal/ash handling
3.	Three turbine generators	190	270 MW each
4.	Turbine Condensers	20	70-95°F cycle
5.	Water treating/BFW	25	Two 500 tph
6.	Cooling water	40	280,000 gpm
7.	DeNox, fly ash SO <sub>2</sub> removal (total flow 750,000 scfm)	60	Three bag houses, single train for ammonia scrubbing
8.	Mercury removal	10	Integrated with bag houses
9.	Transformers-substation	20	includes tie-in to grid
10.	Emergency diesel generators	15	Two 5 MW each
11.	General facilities	55	
	Subtotal	<b>\$590 MM</b>	
	Add 40% contingency	\$236 MM	
	<b>Total power generation</b>	<b>\$826 MM US Gulf</b>	



## Tankage And General Storage

The estimate of storage tanks include dikes, interconnecting piping within the storage facility, vapor recovery when applicable:

		<u>Million U.S. \$</u>	<u>Comments</u>
1.	Feed storage tanks	65	Bitumen/diluents and isobutane
2.	Products storage tanks	85	
3.	Intermediate storage tanks	120	
4.	Solids storage	5	coke/coal/ash/sulphur
5.	Pressurized ethylene underground	5	
	Subtotal	<b>\$280</b>	
	Add 40% contingency	\$112	Including much of interconnecting piping
	<b>Total storage</b>	<b>\$392 US Gulf</b>	

## Other Offsites

The left column of the following table illustrates the average cost of offsites to a US Gulf Coast refinery. The right column illustrates the adjusted values for the proposed project except for the Edmonton location factor. The basis of the table is \$4,452 MM U.S. estimated for ISBL fuels and petrochemicals, including contingency.

	<b>U.S. Gulf Coast</b>		<b>Edmonton Location</b>	
	<b>%</b>	<b>MM \$ U.S.</b>	<b>%</b>	<b>MM \$ U.S.</b>
Site development	4.6	168	3.6	160
Electrical distribution	4.4	160	5.0	223
Cooling water	2.4	87	3.0	133
Flare system	2.2	80	2.2	98
Effluent treating	3.3	117	1.0	45
Boiler/power plant	4.6	168	18.5	826
Building/Furnishing	1.8	66	2.0	89
Interconnecting pipes	5.6	205	2.0	89
Tank farm	14.8	540	8.8	392
Blending	2.0	73	0.5	22
Loading racks	0.2	7	0.2	9
Marine facility	4.5	165	0	0
<b>Total cost OSBL, including power plant and 40% contingency</b>	50.4%	<b>\$1,836</b>	<b>46.8%</b>	<b>\$2,086</b>

### 5.3.5 License Fees And Land Costs

License fees and land costs are usually negotiated items. A generic 2.5% of ISBL cost as a licensing fee is \$95 MM US. An average running royalty of \$0.10/bbl of bitumen feed is assumed, which is \$10.5 MM/year.

### 5.3.6 Working Capital

The majority of working capital is attributed to net receivables, inventory in transit, and inventory in storage tanks. Net receivables and inventory in transit are approximated as one month's gross sales revenue or about \$528 million. To calculate inventory in storage we assume the feed tanks are at 66% of capacity, the intermediate tanks at 66% capacity and product storage tanks at 33% capacity except 100% in the ethylene underground 7 days storage facility.

Based on the above the value of inventory is:

		<b>MM \$</b>
1.	Bitumen 1,600,000 bbl	40
2.	Fuel products	45
3.	Petrochemicals	20
4.	Intermediate storage	90
5.	Subtotal inventory	195

An allowance for miscellaneous working capital of 1.5% of ISBL equals \$65 MM and brings the total working capital to \$778 MM.

### 5.3.7 Project Contingency

This study has not addressed the issue of future optimization that could typically reduce project cost by 10-15%. For example if the two 50% trains of diesel hydrotreating (\$300 MM ISBL plus \$100 MM OSBL) were built as a single unit, a probable savings of \$70-100 MM could be achieved by using a single 100% unit. Therefore, in our view, such optimizations should be addressed in more detailed engineering studies for such a project.

We are aware of a number of cost overruns occurred in recent projects in Western Canada. However, the reasons and the causes are not sufficiently known to us nor are the assumptions of the original cost estimates that were exceeded. Therefore, we cannot methodically analyze these cost overruns in terms of risk analysis, and are unable to factor this important experience into our cost analysis. Hence, the 40% contingency has been added to the capital cost of this project.

### 5.3.8 Project Expenditure Curve

Based on prorating other large projects, the following expenditure curve is projected assuming initial project release at Jan 1<sup>st</sup> 2007. In addition, a 5% compounded annual escalation for each year of project execution is included in the economic model.

Year 2007	2%
Year 2008	13%
Year 2009	35%
Year 2010	30%
Year 2011	13%
Year 2012	7%

### 5.3.9 Total Project Costs

	<b>MM \$ U.S.</b>
Total ISBL with 40% Contingency	<b>4,452</b>
Total OSBL with 40% Contingency	<b>2,086</b>
<b>Total Capital Cost with 40% Contingency</b>	<b>6,538</b>
Edmonton Location Adjustment (12% over USGC)	785
License Fees	95
Land Costs	10
<b>Total Instantaneous – Edmonton Area Location</b>	<b>7,428</b>

	<b>Edmonton location (MM \$)</b>
Total instantaneous fixed investment	US \$7,428
Owners Costs	200
Working Capital	778
<b>Total Investment</b>	<b>8,406</b>
Escalation during construction	1,462
<b>Total Investment as Spent US\$</b>	<b>US \$9,868</b>
<b>Total Investment as Spent Cdn\$ @0.8709</b>	<b>Cdn \$11330</b>

Total investment includes the total cumulative investment (fixed investment, plus owner's cost, plus working capital)

## 6.0. ECONOMIC ANALYSIS

### 6.1. Economic Analysis Assumptions

The major components of the project economic analysis consist of the various cost estimates: capital, operating, and applicable escalation rates and contingency allowance. There are also assumptions for the input bitumen price, and the market values for the plant output. The bitumen and fuel products – gasoline, kerosene and diesel- were valued based on historical ratios to the crude oil price forecast from the earlier PGI Study as shown in the table below.

Gasoline, regular RFG	1.23
Kerosene	1.17
Diesel, low sulphur, 40 Cetane	1.17
Bitumen	0.41
Isobutane	0.88
Propane	0.79
Ethane	0.55

Similarly, the petrochemical output values were based on historical relationships to the natural gas price forecast. The West Texas Intermediate crude and associated natural gas price forecasts used in the economic model is from a published source, GLJ Petroleum Consultants Ltd., as shown in Appendix A.6. For all cases except the transportation cost sensitivities, a tariff of \$2.00/bbl was allowed for transporting fuel products from Edmonton to an assumed Chicago terminal in a dedicated clean products pipeline system and \$1.50/bbl tariff for moving the bitumen from Ft. McMurray to the Edmonton area.

Since pure bitumen is not a presently a commodity and so far has been marketed only with diluent, the value of the bitumen is calculated from the price of diluted bitumen using an assumed “fair market” price of the diluent such as 50 API condensate. Furthermore, not all bitumens are equal. Aside from hydrogen content, which is the key parameter for valuating the bitumen and is closely related to API gravity, there are other properties such as aromatics, asphaltene, basic nitrogen, sulphur and salt contents that could affect downstream processing and thus indirectly the value of a specific bitumen. In this study, we used bitumen of 8.5 API gravity containing 9.9 wt% hydrogen and 4.9 wt% sulphur. Based on other data we are led to believe that the hydrogen content of average bitumen is more like 10.5 wt%. On this basis our feed of reference represents a conservative scenario in terms of hydrogen consumption and associated hydrotreating processing.

The following methodology was used for calculating the value of the bitumen. Diluted bitumen, 20.5 API (0.93 specific gravity), is valued at 67% of 38.5 API WTI (West Texas Intermediate). The diluted bitumen is assumed to contain 35 vol% of 50 API condensate and 65 vol% of 8.5 API bitumen. In recent years, the value of the condensate has been about 1.11 times the WTI value, which dictates a bitumen value of 42% of WTI. PGI proposed in their report that bitumen be valued at 41% of the price of WTI. On this basis, we propose an average ratio of 41% of bitumen to WTI.

The cost of isobutane (about 6,000 bpsd), a secondary item, is suggested to be 88 vol% (1.27 on weight basis) of the cost of WTI crude oil based on historical data. The cost of imported fuel oil (700 bpsd) and coal (2,000 tpd) from OBL is of secondary significance and is based on current pricing. The “feed of opportunity” to the steam cracker based historical ratio is about 1.1 times WTI on a weight basis.

During the study phase, it was recognized that the production ratio of diesel to motor gasoline is much higher than the traditional demand ratio in North America, the primary intended market. For simplicity in this study, it was assumed that the market for the production of the liquid fuel products (diesel, gasoline and kerosene) would be the U.S. Midwest. Therefore, the economic analysis is based on pipelining the finished fuel products to Chicago or Great Lakes terminal. Future options of pipelining diesel or other product to British Columbia for export to the Far East or to the U.S. West Coast could be evaluated by study sponsors as separate business cases once the cost of pipelining and terminal storage is further defined.

The model shows the gasoline is comprised of four blend components:

		RON
1.	FCC gasoline	93
2.	Reformate High Octane Blend Component	106
3.	Alkylate, C8	95.5
4.	Light gasoline	79

Due to logistical considerations, all the above gasoline fractions will be moved to market by pipeline as a single blend. Based on a preliminary estimate, the gasoline blend will exceed the octane requirement, sulphur specification, Reid vapor pressure, benzene content and all other specifications for regular reformulated gasoline. The model has the capability of pricing the gasoline fractions separately, enabling the sponsors to conduct sensitivity analyses and evaluation of marketing options. For example, the light gasoline (12.5 RVP and relatively low octane) could be segregated and blended into a gasoline pool more adaptable to high RVP. The alkylate, which has no aromatics, low RVP and high octane, could be sold at premium price as a special blend for CARB gasoline in California if a suitable transportation system became available.

The total blend of gasoline has an estimated road octane  $(89.9 (R+M)/2)$ , which is 2.9 points above the road octane number of regular gasoline. We are suggesting a potential octane credit of  $\$0.60/\text{bbl} \times \text{excess octane}$ . In this case,  $\$1.74/\text{bbl}$  ( $\$0.041/\text{gallon}$ ) is the added octane value. This proposed octane credit is in line with published information like that presented at the CMAI 2005 conference. However, no such credit was taken in the above economic cases.

The same will apply to diesel fuel. Two diesel fuel blends are produced:

1. 56 Cetane Index from hydrocracking
2. 46 Cetane Index from diesel hydrotreating

But in reality they most likely will be blended to a single 48 Cetane Index grade.

The diesel product, besides its high Cetane Index, is ultra low sulphur (under 10 ppm) and very low in aromatics, around 5 wt%, as opposed to 30 wt% aromatics in the average diesel fuel on the North American market. This diesel will be close to par with any future diesel fuel produced by GTL (gas to liquid) especially in terms of sulphur and aromatics and by far more economical to produce. As shown, the energy consumption in producing the fuel and petrochemical products is about 12% of the energy in the bitumen as opposed to 40-45% feed energy consumed during GTL gas conversion processing for producing diesel. Based on the above, we could see a potential credit on the diesel for the higher Cetane Index at \$0.45/bbl x Cetane for Cetane Index values over 42 (40 Cetane number), which is a common benchmark. On this basis the value of the diesel at 46 Cetane Index will be \$2.70/bbl above the base price for diesel. Again, no credit was taken in the economic cases.

The kerosene will be sold on the North American market but due to the relatively smaller quantity of kerosene, no particular attention was given at this point to marketing issues. It is reasonable to assume that a batch operation of a clean product pipeline for diesel, gasoline and kerosene will be built. For the kerosene, we based the price on the historical ratio of kerosene to crude oil. The cost of transporting fuel products from Edmonton to a U.S. Great Lakes terminal is shown in the model as \$2.00/bbl. However, the avoidance of pipelining about an equal amount of synthetic crude and replacing it with fuel products make it even more attractive.

Excess pure hydrogen (99.9 vol%, 50 ppm CO) at 800 psig will be pipelined to assumed present and future users. The suggested cost of hydrogen for small users, say under 50 MM scfd, would be indexed to the cost of natural gas, which accounts for 80-85% of the cost of producing hydrogen by steam methane reforming. The small users do not have an economical alternative to steam methane reforming such as gasification of low value feedstock as would be the case for large hydrogen consumer.

The following formula is used to value ethylene:

$$\text{Ethylene, cents/lb} = \text{WTI } \$/\text{bbl} \times 0.5471 + 9.915$$

We are of the opinion that this formula represents a good long-range prediction of pricing, however with an expectation of significant fluctuations on a short-range pricing. The value of butadiene is 90% the value of ethylene based on historical data. Propylene is valued at 1.24 times WTI on volume basis (2.1 on weight basis). The produced butadiene and pyrolysis gasoline (which is highly enriched in benzene) will be sold to the U.S. Gulf Coast with an appropriate netback after allowing for the rail freight cost.

Pyrolysis gasoline is a primary source of benzene, thus in the case of pyrolysis gasoline, a further upward cost adjustment will be made for the relatively higher benzene content, about 72 wt%, as oppose to an average of about 50 wt%. No credit to this effect was given in the model. Thus we are on the conservative side as well. The cost of transporting both butadiene and pyrolysis gasoline to the U.S. Gulf Coast is shown in the model as \$6.00/bbl.

For establishing the values for both the ammonia synthesis gas and the ammonium sulfate, unlike the hydrogen case, we are using a “discounted” natural gas reference price of \$4.0 US/MM Btu HHV. This \$4.0/MM Btu for natural gas is the estimated economical threshold for ammonia producers for switching ammonia production from steam methane reforming to gasification of zero value feedstock while producing 200 MM scfd or more of hydrogen at the Edmonton location.

The project is a large producer of pure CO<sub>2</sub>. At this point no credit was given to the future option of using CO<sub>2</sub> for enhanced oil recovery (EOR). Some 20,000 tpd of CO<sub>2</sub> could be recovered in pure form and portion of the proposed redundant power capacity could be used for compressing the CO<sub>2</sub>. A small portion of the CO<sub>2</sub> would be available for producing urea. The price of elemental sulphur is assumed to be zero and the cost of piling and storing the sulphur is relatively small in terms of the overall project economics.

The economic model incorporates an investment associated with the redundant 270 MW power generation unit using coal fired boilers. This redundant capacity is introduced because of the expectation of heavy demand charges in the event of an unscheduled shut down of the internal power generation unit. The issue of the demand charge could be reviewed once the project becomes closer to reality, but as of now redundant capacity is incorporated with the option of selling power to the grid on an interruptible basis. A value of \$0.045 US/KWH is suggested as alternate case as opposed to \$0.07/KWH US, which is the current average cost of electric power in Alberta. This credit was not included in the above cases.

## **6.2. The Economic Model**

An economic model of the proposed bitumen processing plant was developed to determine the financial feasibility of the project. The crude and natural gas price assumptions used in the economic model are tabulated in Appendix 6. The model is in Excel format and will be made available on CD for use by prospective sponsors, and may be adjusted to include their individual assumptions on the various parameters contained in the model.

## **6.3 Economic Analysis Results**

The model is divided into two main sections:

### Bitumen processing plant in 2015 (base case)

The economic analysis gives a breakdown of the projected product revenues, material costs, conversion costs, capital costs, financial costs and other miscellaneous costs in 2015. The Return on Investment (ROI) is calculated to show the earnings on a standalone basis for the project's total asset base.

### Cash Flow Analysis over years 2007 to 2031 (base case)

The cash flow analysis is a screening tool that can assist in determining the long-term financial feasibility of the project based on the net present value (NPV) and DCFR.

The following cost factors are included in the economic model:

1.	Capital investment, December 2005, U.S. Gulf Coast	<b>\$6,538,000,000</b>
2.	Escalation in investment to Edmonton location verses U.S. Gulf Coast	12%
3.	Discounted Cash Flow rate	15%
4.	Escalation of capital during construction	5.0% per year
5.	Working capital	\$778 MM
6.	License fees	\$95 MM +\$10MM per year
7.	Land costs	\$10 MM
8.	Cost of labor	\$201 MM per year
9.	Sustaining capital	\$89 MM per year
10.	Insurance and taxes	\$148 MM per year
11.	Owner cost	\$200 MM

As discussed in Section, the capital cost estimate contains a 40% contingency allowance in accordance with the Class V quality of the estimate.

The Internal Rate of Return (IRR) over 24 years was calculated by the discounted cash flow (DCF) method and the reference case results and sensitivities are shown below. Other than for the price and cost changes, the sensitivity cases are the same as the reference case. The transportation cost sensitivities compare to \$2/barrel in the reference case, and the Edmonton location factor in the reference case is 12%. The reference case product value to crude ratios is taken from the PGI market studies mentioned above.

- Reference Case: GLG WTI crude price forecast 19.5% IRR
- + \$10/barrel in the crude price forecast 23.0% IRR
- - \$10/barrel in the crude price forecast 15.6% IRR
- + 10% in capital cost 18.1% IRR
- - 10% in capital cost 21.0% IRR
- \$3/barrel product transportation cost 19.1% IRR
- \$4/barrel product transportation cost 18.6% IRR
- Edmonton location factor of 25% 18.0% IRR
- 2004-2005 Average product to crude value ratios 19.9% IRR

The return on investment calculations must be treated as hypothetical at this stage of project development, based as they are on a conceptual process design, and derived from many assumptions about conditions in a future timeframe. To go beyond the conceptual stage of this project, as noted above, would require multi-million dollar engineering design studies to raise the cost estimate quality from the Class V level to Class III and a decision to proceed. The purpose of the conceptual study was to stimulate interest in pursuing further studies, rather than to provide an engineering design for the construction of such a plant.



## **7.0. RECOMMENDATIONS FOR FUTURE STUDIES**

As expected, developments during the preparation of the study and in ongoing discussions with the sponsors, several issues have surfaced that would need further study and corroboration. On the technical end, further corroboration of the bitumen analysis, including trace components, is required. Since the licensors support in this phase of the study was limited, all issues of yields of the major conversion units (such as the delayed coker, FCC and hydrocracker) would need further definition, probably under secrecy agreements with licensors. In addition to the above, the following issues could be legitimate subjects for further studies.

### **7.1. Phased Construction**

Financial exposure and availability of construction and engineering manpower could become an issue. A peak engineering task force of over 1,200 people and a 6,000-8,000 or more peak construction work force may be required to accomplish this task. The financial exposure for project proponents will be several billion dollars. To mitigate this exposure, the facility could be built in phased construction for example:

- Phase one: 150,000 bpsd single train upgrader refinery
- Phase two: second 150,000 bpsd and associated petrochemicals

The first phase will include one or two of the three proposed power generation units and one or two of the three ASU hydrogen production units depending on ammonia syngas. What will become advantageous feed to the future steam cracker will be disposed on a temporary basis, probably in a non-economical way, such as a component of a synthetic crude blend. The economic disadvantage of phased construction issues needs to be evaluated against other issues. No simple solution is at hand.

### **7.2. Market Logistics And Terminals**

At the moment, the Province of Alberta is an exporter of crude oil, synthetic crude, ethylene derivatives and ammonia. However, Alberta is not known to be an exporter of finished fuel products outside of adjacent provinces. Thus no infrastructure is currently in place for shipments to US or offshore markets. Oil products are exported from Eastern Canadian refineries to the U.S. However these issues and logistics are totally different and not related to the business case for the Alberta situation. At the moment we are assuming that export markets in the US Midwest will absorb the fuel products. California and Asian markets represent other potential outlets. These export markets must be accessed via pipelines and ocean tankers. The export of ethylene and propylene derivatives is also requires the identification of market outlets.

The following appear to be potential outlet terminals for this proposed upgrader export refinery:

1. Vancouver BC area for the U.S. West Coast and Far East markets

2. Prince Rupert BC for U.S. West Coast and Far East markets
3. U.S. Great Lakes for the U.S. Midwest market
4. U.S. Gulf Coast for a limited supply of petrochemicals

Accessing these markets will require new product pipelines, land terminals, marine terminals plus environmental and construction permits.

### **7.3 Plot Plan And Site Selection Study**

Any further refinement of the cost estimate, especially the offsites, will require at least a preliminary plot plan. Such a generic plot plan, yet to be developed, would become very helpful in site selection. Although in general the Redwater area is a possible location, other potential sites in the area will need to be evaluated for land options, environmental permits and ultimately the purchase of the land.

### **7.4. Onsite Ammonia Production**

At the moment 3,000 tpd of ammonia synthesis gas is shown to be consumed by the existing Agrium complex in Redwater. Although this integrated method results in lower capital investment as opposed to construction of a new ammonia plant, the real choice is not clear. By the year 2012, the ammonia production facility at Agrium will be 30 years old. One could argue that integrating a complex to an existing ammonia synthesis loop would have to be evaluated against the option of building a new single ammonia synthesis loop. We are aware that issues of urea and other ammonia derivatives may surface. From the business venture side, building a new ammonia synthesis loop will likely simplify many issues. Based on today's prices of ammonia and natural gas, this option may show a slightly higher rate of return opposed to the present scheme.

### **7.5. Other Ammonia Options**

With the present conceptual scheme, it is estimated that about \$550 MM US is dedicated directly and indirectly toward producing 3,000 tpd of ammonia synthesis gas. This includes prorated investment in power generation equivalent to 115,000 KW dedicated for ammonia. In addition, avoiding ammonia synthesis gas production will reduce coke consumption by 3,000 tpd. Avoidance of ammonia synthesis gas production all together could be substituted by two options:

- Increasing hydrogen export from 128 MM scfd to 350 MM scfd while maintaining about the same capital spending. Based on today's market for natural gas, this option will achieve a higher rate of return by about 0.3% if a market for hydrogen exists.
- Omit ammonia synthesis gas production. Eliminate one of the three hydrogen production trains, and eliminate the 900 tpd coke import from Petro-Canada and the 2,000 tpd coal import from OBL. Divert excess coke to the fluidized bed boilers. In order to dispose of the coke, the export of some 180-200 MW of electric power would be necessary. The reduction in capital spending will be probably on the order of \$500 MM US Gulf. As a first guess, it appears that the calculated rate of return on this option will be slightly higher, probably about 0.3% compared to the present

configuration, but capital exposure and business issues could become more manageable.

Exporting high-pressure steam from the complex, especially from spare boiler capacity, to other users could be an attractive option and should be a part of the proposed evaluations of the ammonia options above.

## **7.6 Olefin Plant Configuration**

All olefins technologies are using conventional steam cracking and cold product fractionation for ethylene recovery. As discussed in the olefin section, different fractionation systems are offered by the licensors. Given the unique case of the project, multiple feeds, unconventional feeds and potential trace components in feedstock will require a careful assessment of all relevant process technologies. All the above are likely to encounter many unknown issues that need further study and definition. One key issue is the cold fractionation sequence.

## **7.7. Butadiene Recovery**

The issue of raffinate separation of the C<sub>4</sub> olefins and n-butane via extractive distillation needs some further study as a follow-up to the olefin plant configuration study.

## **7.8 Electric Power Issues**

The topics of electric power, redundant capacity and power exports are well described in prior chapters including the economic analysis. Once a specific project case is well defined, we recommend revisiting these issues. As of now the conceptual setting of the power generation is based on the assumption of the very high cost of demand charges for grid power supply in event of an unscheduled shut down of a power generation unit.

## **7.9. Vacuum Distillation**

At the moment we have selected a dry vacuum system; however given the relatively lower cost for steam, a wet system using steam injection is worth further evaluation.

## A.0. APPENDICES

### A.1. Integration Study Industry Sponsor Companies

<p><b>Agrium Inc.</b> 13131 Lake Fraser Drive SE Calgary, AB T2J 7E8</p>	<p><b>Japan Canada Oil Sands Ltd.</b> 2300 Standard Life Building 639 – 5 Avenue SW Calgary, AB T2P 0M9</p>
<p><b>Air Products and Chemicals Inc.</b> 3000, 150 – 6<sup>th</sup> Avenue SW Calgary, AB T2P 3Y7</p>	<p><b>National Centre for Upgrading Technology</b> 1 Oil Patch Drive, Suite A202 Devon, AB T9G 1A8</p>
<p><b>ATCO Pipelines</b> Suite 1300, 909 – 11 Avenue SW Calgary, AB T2R 1L8</p>	<p><b>NOVA Chemicals Corporation</b> 1000 Seventh Avenue SW Box 2518, Station M Calgary, AB T2P 5C6</p>
<p><b>BOC Process Gas Solutions</b> 575 Mountain Avenue Murray Hill, NJ 07974</p>	<p><b>Petro-Canada</b> 150 – 6 Avenue SW Calgary, AB T2P 3E3</p>
<p><b>BP Canada Energy Company</b> 240 – 4 Avenue SW Calgary, AB T2P 2H8</p>	<p><b>PraxAir Inc.</b> Suite 130, 7260 – 12 Street SE Calgary, AB T2H 2S5</p>
<p><b>Canadian Association of Petroleum Producers</b> 2100, 350 – 7 Avenue SW Calgary, AB T2P 3N9</p>	<p><b>Saskferco Products Inc.</b> Box 39, Kalium Road Belle Plaine, SK S0G 0G0</p>
<p><b>Canadian Natural Resources Ltd.</b> Suite 2500, 855 – 2 Street SW Calgary, AB T2P 4J8S</p>	<p><b>SinoCanada Petroleum Corporation</b> Suite 1705, 639 – 5 Avenue SW Calgary, AB T2P 0M9</p>
<p><b>Dow Chemical Canada Inc.</b> Suite 2200, 250 – 6 Avenue SW Calgary, AB T2P 3H7</p>	<p><b>TransAlta Corporation</b> Box 1900, Station M 110 – 12 Avenue SW Calgary, AB T2P 2M1</p>
<p><b>Enbridge Pipelines Inc.</b> 3000, 425 – 1 Street SW Calgary, AB T2P 3L8</p>	<p><b>TransCanada</b> 450 – 1 Street SW <b>Calgary, AB T2P 5H1</b></p>
<p><b>EnCana Midstream &amp; Marketing</b> 1800, 825 – 2 Street SW Calgary, AB T2P 2S5</p>	

## A.2. Site And Climate Data

### SITE DESIGN BASIS

The following is climate data for Namao (located 10 miles west of Agrium site) and about the same elevation above sea level.

Elevation – 687.9 metres (2258.9 feet above sea level)

Minimum extreme temperature      minus 42.2

Minimum design temperature      minus 40 C or minus 40 F

Maximum extreme temperature      33.9 C

Maximum design temperature      26 C or 80 F (for ambient temperature for air cooler design)

Atmospheric pressure    use 93.3 kpa (13.5 psia)

	Jan	Feb	Mar	Apr	May	Jun	Jul	Aug	Sep	Oct	Nov	Dec	Year	Code
Daily Average (°C)	-12.1	-10.1	-3.5	4.8	11.1	14.7	16.5	15.6	10.5	4.9	-4.9	-10.6		A
Standard Deviation	5	5.4	3.7	2.2	1.3	0.9	1	1.8	2	1.7	3.9	4.4		A
Daily Maximum (°C)	-7.6	-5.3	1.3	10.6	17.3	20.5	22.2	21.4	16.3	10.5	-0.6	-6.2		A
Daily Minimum (°C)	-16.6	-14.8	-8.2	-1.1	4.8	8.8	10.8	9.7	4.7	-0.7	-9.1	-15		A
Extreme Maximum (°C)	10	13.9	16.3	29.6	31.9	33.9	<b>33.9</b>	33.9	32.8	28.4	18.9	10.6		
Date (yyyy/dd)	1968/23+	1988/26	1994/30	1977/26	1986/30	1961/04+	<b>1959/23+</b>	1990/06	1981/17	1987/02	1975/03	1956/28+		
Extreme Minimum (°C)	<b>-42.2</b>	-38	-35	-23.3	-7.2	-1.1	2.8	-2	-7.8	-24.5	-35.4	-39.2		
Date (yyyy/dd)	<b>1972/26</b>	1989/02	1962/01	1982/03	1963/03+	1969/12	1967/25	1992/22	1974/30	1984/31	1985/26	1977/09		
<b>Precipitation: Precipitation:</b>														
Rainfall (mm)	1.3	0.5	1.7	8.3	40.9	88.6	95.7	74.7	37.9	9.9	1.8	1		A
Snowfall (cm)	21.7	17.2	17.3	13	3.6	0	0	0.2	1.8	7	15.4	23.7		A
Precipitation (mm)	19.7	14	17.3	20.2	44.7	88.6	95.7	74.8	39.6	16.4	14.3	21		A
Average Snow Depth (cm)	16	17	12	2	0	0	0	0	0	1	4	11		A
Median Snow Depth (cm)	17	16	11	1	0	0	0	0	0	0	4	10		A
Snow Depth at Month-end (cm)	17	17	6	0	0	0	0	0	0	1	6	13		A
Extreme Daily Rainfall (mm)	10.4	3	6.6	17	49.6	<b>94.7</b>	78.4	69.6	53.3	23.6	7.4	10.2		
Date (yyyy/dd)	1965/14	1977/16	1972/10	1978/28	1991/13	<b>1965/27</b>	1990/03	1960/04	1969/04	1981/08	1978/07	1957/08		
Extreme Daily Snowfall (cm)	22.2	<b>24.1</b>	23.9	23.5	19.7	1.5	0	4.6	7.2	22.9	14.2	21.6		
Date (yyyy/dd)	1989/30	<b>1961/15</b>	1974/13	1985/20	1987/19+	1967/09	1956/01+	1992/21	1984/22	1970/25	1982/06	1974/21		
Extreme Daily Precipitation (mm)	16.6	24.1	23.9	22.8	49.6	<b>94.7</b>	78.4	69.6	53.3	23.6	13.7	21.6		
Date (yyyy/dd)	1989/30	1961/15	1974/13	1985/20	1991/13	<b>1965/27</b>	1990/03	1960/04	1969/04	1981/08	1960/24	1974/21		

Extreme Snow Depth (cm)	59	64	76	48	15	0	0	0	5	25	28	46		
Date (yyyy/dd)	1956/28+	1965/08	1974/15	1974/01+	1987/20	1956/01+	1956/01+	1956/01+	1970/24	1970/26	1964/28+	1970/08		
<b>Days with Maximum Temperature: Days with Maximum Temperature:</b>														
<= 0 °C	23.1	17.9	11.4	1.9	0	0	0	0	0.12	2.1	14.4	22.3		A
> 0 °C	7.9	10.3	19.6	28.1	31	30	31	31	29.9	28.9	15.6	8.7		A
> 10 °C	0	0.46	2.5	16	28	29.8	31	30.8	25.1	16.9	1.3	0.04		A
> 20 °C	0	0	0	2.1	9.5	16.1	21.5	19.7	8.4	2.3	0	0		A
> 30 °C	0	0	0	0	0.25	0.29	0.58	0.75	0.08	0	0	0		A
> 35 °C	0	0	0	0	0	0	0	0	0	0	0	0		A
<b>Days with Minimum Temperature: Days with Minimum Temperature:</b>														
> 0 °C	0.32	0.63	1.9	11.6	28	30	31	30.9	26.5	13.6	1.3	0.5		A
<= 2 °C	30.9	28.1	30.7	22.9	6.4	0.25	0	0.42	6.8	22.7	29.8	30.9		A
<= 0 °C	30.7	27.6	29.1	18.4	3	0	0	0.13	3.5	17.4	28.7	30.5		A
< -2 °C	30.1	26.4	24.8	10.7	0.75	0	0	0	1.6	10.3	26.3	30		A
< -10 °C	21.8	18.3	10.8	1.6	0	0	0	0	0	1.1	11	20.8		A
< -20 °C	10.7	8.5	2.3	0.17	0	0	0	0	0	0.08	2.7	8.5		A
< -30 °C	2.8	1.7	0.08	0	0	0	0	0	0	0	0.13	2		A
<b>Days with Rainfall: Days with Rainfall:</b>														
>= 0.2 mm	0.76	0.76	1.1	4.2	10	15.1	14.3	13.1	9.6	4.5	1.5	1		A
>= 5 mm	0.08	0	0.04	0.29	2.7	5	4.9	4	2.4	0.5	0.04	0		A
>= 10 mm	0	0	0	0.13	1	2.4	2.6	2.2	1.1	0.08	0	0		A
>= 25 mm	0	0	0	0	0.08	0.54	0.92	0.72	0.12	0	0	0		A
<b>Days With Snowfall: Days With Snowfall:</b>														
>= 0.2 cm	10.3	8.4	7.1	3.8	0.84	0	0	0.08	0.92	2.9	7.1	10.2		A
>= 5 cm	1.2	0.8	1	0.83	0.2	0	0	0	0.12	0.54	0.75	1.3		A
>= 10 cm	0.32	0.12	0.25	0.33	0.12	0	0	0	0	0.08	0.21	0.21		A
>= 25 cm	0	0	0	0	0	0	0	0	0	0	0	0		A
<b>Days with Precipitation: Days with Precipitation:</b>														
>= 0.2 mm	10.2	8.4	7.8	6.7	10.4	15.1	14.3	13.1	10	6.6	7.8	10.2		A
>= 5 mm	1	0.56	0.88	1.1	2.9	5	4.9	4	2.5	0.92	0.71	1.1		A
>= 10 mm	0.2	0.08	0.17	0.42	1.1	2.4	2.6	2.2	1.2	0.21	0.13	0.17		A
>= 25 mm	0	0	0	0	0.16	0.54	0.92	0.72	0.12	0	0	0		A
<b>Days with Snow Depth: Days with Snow Depth:</b>														
>= 1 cm	30.8	27.6	23.8	5.7	0.48	0	0	0	0.16	2.5	16.2	27.5		A
>= 5 cm	28.1	23.6	18.5	3.6	0.16	0	0	0	0	1.7	10.8	23.5		A
>= 10	23.4	18.6	13.1	2.5	0.04	0	0	0	0	0.75	3.8	17.6		A
>= 20	9.5	9.4	6	1.3	0	0	0	0	0	0.04	0.75	4		A
<b>Wind: Wind:</b>														

Speed (km/h)	13.1	12.8	12.6	14.2	14.9	13.9	12.4	11.6	13.2	13.8	12.4	13.2	13.2	B
Most Frequent Direction	SW	SW	W	W	W	W	W	W	W	W	W	W	W	B
Maximum Hourly Speed	84	84	80	76	80	80	66	<b>89</b>	72	77	84	77		
Date (yyyy/dd)	1971/08	1964/21	1964/15	1962/24	1965/16	1961/30	1964/09	<b>1965/13</b>	1958/13	1958/03	1959/02	1960/30		
Direction of Maximum Hourly Speed	NW	NW	NW	E	NW	W	E	NW	NW	NW	NW	NW	NW	
Maximum Gust Speed	108	122	109	114	101	134	<b>138</b>	134	109	134	126	106		
Date (yyyy/dd)	1971/08	1959/28	1964/15	1964/10	1960/14+	1961/30	<b>1974/30</b>	1965/13	1973/11	1965/01	1961/01	1958/31		
Direction of Maximum Gust	NW	NW	NW	NW	NW	W	W	NW	W	W	NW	NW	W	
Days with Winds >= 52 km/hr	1.1	0.5	0.4	1.3	1.4	1.4	1.3	0.6	1	1.3	0.7	0.8		A
Days with Winds >= 63 km/hr	0.3	0.2	0.1	0.3	0.1	0.3	0.4	0.3	0.1	0.2	0.3	0.3		A
Degree Days: Degree Days:														
Above 24 °C	0	0	0	0	0	0	0.1	0.1	0	0	0	0		A
Above 18 °C	0	0	0	0.2	2.6	6.9	18	17.6	1.3	0	0	0		A
Above 15 °C	0	0	0	1.4	12	32.4	62.6	56.8	8.5	1.1	0	0		A
Above 10 °C	0	0	0	12.4	69.6	142.5	201.8	176.4	61.5	13.9	0.1	0		A
Above 5 °C	0.1	0.8	2.8	58.1	193.1	290.4	356.7	328	173.3	63.7	2.5	0.1		A
Above 0 °C	4.7	10.6	33.8	163	343.8	440.4	511.7	483	315.4	172.4	21.6	4.8		A
Below 0 °C	379.9	294.4	141.2	19.5	0.1	0	0	0	0.5	19.6	168.2	334.6		A
Below 5 °C	530.4	425.8	265.2	64.6	4.3	0	0	0.1	8.4	66	299	484.8		A
Below 10 °C	685.3	566.3	417.4	168.9	35.9	2.2	0.1	3.4	46.6	171.1	446.6	639.8		A
Below 15 °C	840.3	707.5	572.4	307.9	133.2	42.1	15.9	38.9	143.6	313.4	596.6	794.8		A
Below 18 °C	933.3	792.3	665.4	396.6	216.9	106.5	64.3	92.6	226.4	405.3	686.6	887.8		A
Humidex: Humidex:														
Extreme Humidex	9.8	13	16.1	28.9	34.9	38.4	37.8	<b>41.5</b>	36.2	27.8	18.9	12.8		
Date (yyyy/dd)	1993/30	1988/25	1964/31+	1977/26	1958/28	1961/05	1956/20	<b>1998/05</b>	1967/05	1987/02	1975/03	1999/27		
Days with Humidex >= 30	0	0	0	0	0.2	0.5	2.8	3.3	0.3	0	0	0	7.2	B
Days with Humidex >= 35	0	0	0	0	0	0	0.3	0.2	0	0	0	0	0.6	B
Days with Humidex >= 40	0	0	0	0	0	0	0	0	0	0	0	0	0	B
Wind Chill: Wind Chill:														
Extreme Wind Chill	<b>-57.1</b>	-51.3	-45.9	-30.8	-14.2	-4.9	0	-4.6	-15.5	-35.4	-52.8	-56.4		
Date (yyyy/dd)	<b>1972/26</b>	1989/02	1962/01	1982/04	1963/03	1967/09	1966/22	1992/22	1974/30	1984/31	1985/26	1964/15		
Days with Wind Chill < -20	18	14.6	6.6	0.9	0	0	0	0	0	0.4	6.7	14.9	62	B
Days with Wind Chill < -30	9.3	6.6	1.4	0	0	0	0	0	0	0	1.5	7.3	26.1	B
Days with Wind Chill < -40	2.7	1.3	0.1	0	0	0	0	0	0	0	0.2	2	6.2	B
Humidity: Humidity:														
Average Vapour Pressure (kPa)	0.2	0.3	0.4	0.5	0.7	1	1.3	1.3	0.9	0.6	0.4	0.3	0.6	B
Average Relative Humidity - 0600LST (%)	74.1	75	79.3	76.1	73.7	80.6	86	88.3	85.9	77.4	79.8	76.2		A

<b>Average Relative Humidity - 1500LST (%)</b>	68	64.6	61.4	45.5	41.1	49.3	54.6	54.5	53.3	50.2	66.8	70.3		A
<b>Pressure: Pressure:</b>														
<b>Average Station Pressure (kPa)</b>	93.3	93.3	93.1	93.2	93.2	93.1	93.4	93.4	93.4	93.2	93.1	93.2	93.3	B
<b>Average Sea Level Pressure (kPa)</b>	101.8	101.8	101.5	101.5	101.3	101.2	101.4	101.5	101.5	101.5	101.5	101.7	101.5	B
<b>Visibility (hours with): Visibility (hours with):</b>														
<b>&lt; 1 km</b>	10.5	10.3	12.6	6	1.7	1.6	1	3.8	4	5.2	24	13.3		A
<b>1 to 9 km</b>	95.5	85.7	79.5	33.2	21.7	21.8	20	27.1	22.8	28	84.3	91.8		A
<b>&gt; 9 km</b>	638	582	651.8	680.8	720.6	696.6	723	713.1	693.2	710.8	611.7	639		A
<b>Cloud Amount (hours with): Cloud Amount (hours with):</b>														
<b>0 to 2 tenths</b>	177.4	152.8	166	159.9	144.4	114.1	155.9	178.7	173.3	184.1	149.9	168.1		A
<b>3 to 7 tenths</b>	164.4	157.7	190.3	219.4	239	249	276.6	260.3	192.8	202.7	158.8	165.9		A
<b>8 to 10 tenths</b>	402.2	367.6	387.7	340.8	360.6	356.9	311.5	305	353.9	357.2	411.3	410		



### **A.3. Terms Of Reference**

#### **BITUMEN PROCESSING INTEGRATION STUDY - 2005**

- 1. Purpose of Study**
- 2. Background**
- 3. Scope of Work**
- 4. Deliverables**
- 5. Study Guidelines**
- 6. Specific Terms and Conditions**
- 7. Study Schedule**
- 8. Project Management Team**
- 9. Terms of Payment**

## **PURPOSE OF STUDY**

Building on the previous studies by T. J. McCann and Purvin & Gertz to assess the product integration opportunities for chemical feedstocks, petrochemicals, fertilizers, synthesis gas and electricity production, or other products as appropriate, in association with bitumen upgrading and refining in Alberta.

To create a new base case study, which will become the benchmark for future studies.

To analyze opportunities for capital and operating savings and revenue enhancement and diversification through integration of by-product or co-product production with existing, planned or potential upgrading, refining, fertilizer, chemical or electrical generation operations in Alberta using advantageous feed.

To identify, select and evaluate appropriate technologies and processes to maximize value of products attained from processing bitumen and bitumen derived feedstocks.

To determine the most economic scale of operation, volume and cost of products and potential revenue associated with each product.

To quantify the return on investment for the proposed configuration and illustrate where integration led to improvement in economic attractiveness relative to only upgrading and refining.

## **BACKGROUND**

The Alberta Hydrocarbon Upgrading Task Force (HUTF) has identified one of its priorities is to continue to build a business case for a world-class upgrading, refining and petrochemicals industry cluster in Alberta.

The Alberta Government and Industry partners have undertaken studies, demonstrating the feasibility of producing petrochemicals from bitumen derived feedstocks, and of adding a refinery component to bitumen upgrading operations.

Further refinement of the technology, process and plant configuration, and product slate, is required to assess business case improvement resulting from integrated operations.

## **SCOPE OF WORK**

The study will examine opportunities for co-production of some or all of the following; synthetic crude oil, refined petroleum products, petrochemicals and petrochemical feedstocks, fertilizers, synthesis gas, electricity plus any other products that will enhance the economic attractiveness of an integrated upgrading facility. The study need not consider petrochemical derivative products such as polyethylene, polypropylene, polystyrene, ethylene glycol or other derivative products. Potential markets for selected products will be identified. The most appropriate combinations of technologies and feedstocks will be proposed and an economic evaluation will be undertaken using the selected technologies,

feedstocks, products and markets. Capital costs, operating costs and sales revenues attributable to each product will be identified where applicable.

The consultant, based on his judgment and experience, will select the appropriate combination of facilities, technologies and products, and scale of operation, to develop a project to optimize economic returns from processing bitumen in Alberta.

All appropriate technologies may be considered. The study may consider opportunities for new integrated facilities and across the fence product or feedstock exchanges with existing facilities. Proposals should identify which processes, technologies, products, and outside facilities will be included in the study as a basis for developing the business case economics for an integrated facility. Proposals should also indicate approximately what volume of bitumen feedstock is likely to be considered. Methodology for developing process integration schemes, capital costs, operating costs and other study materials should be described in the proposal.

Based on the forecast inputs and steering committee consultation, the consultant will develop a business case that assesses the feasibility, requirements and profitability of developing a project to construct and operate the proposed process. This should incorporate all components including an assessment of expected markets and earnings, (i.e., sales revenues less costs) for the project.

## **DELIVERABLES**

The winning bidder will participate in a kickoff meeting and two interim progress meetings with the study steering committee in order to receive feedback and direction. Presentations will be made to study sponsors at interim progress meetings and at the conclusion of the study. Presentation materials will be provided in both hard copy and electronic (Power Point or PDF format). The final report will synthesize the information and analysis developed for the study, and provide direction and recommendations for further enhancement of the business case. The Executive Summary of the report will describe the proposed project, processes and products, present the overall conclusions, and show the results of the financial and economic analysis. The body of the report will discuss all underlying assumptions, describe in detail all material flows and balances, all processes and plant, all capital and operating cost data, and will include all flow sheets, drawings and backup data except those of a proprietary nature. It will also include an analysis that assesses both the cost and revenue streams to reflect the overall market development potential of the proposed process. The consultant will use current forecast input and product prices, which will be developed in consultation with the study steering committee. This analysis will also examine sensitivity to major study variables also developed in consultation with the steering committee. For the purpose of comparison with previous studies, an economic analysis utilizing the same input and product price assumptions as used in the Purvin & Gertz Phase II – Refined Products and Petrochemicals from Bitumen study will also be provided.

The contractor will supply 25 hard copies of the Final Report, an electronic copy of the Final Report and a PowerPoint presentation.

## **STUDY GUIDELINES**

The contractor will work under the guidance of the study Steering Committee.

The study report will become a public document upon acceptance of the final report.

## **SPECIFIC TERMS AND CONDITIONS**

In addition to the terms and conditions in the agreement:

The contractor will obtain information outside of their area of expertise by subcontracting with other consultants. The proposal shall indicate the names of subcontractors to be included in the study, if any.

Contract Basis: Contract price and terms to be negotiated with the study steering committee.

The Contractor will be provided with relevant materials that are in the possession of Alberta Economic Development, Alberta Energy and Industry Sponsors of the study.

The Contractor will submit a draft report for Steering Committee approval prior to completion of the final report.

## **STUDY SCHEDULE**

Starting date and kickoff meeting – Sept. 27, 2005

Interim Progress Meeting – Nov. 1, 2005

Interim Progress Meeting – Dec. 6, 2005

Submission of Draft Report – Jan. 10, 2006

Submission of Final Report – Jan. 31, 2006

Presentation to AED and Sponsors of Study – Feb 14, 2006

Schedule may be modified by mutual consent among study members and contractor.

## **PROJECT MANAGEMENT TEAM**

Mr. Ed Condrotte  
Alberta Economic Development  
5<sup>th</sup> Floor, 10155-102 Street  
Edmonton, Alberta, T5J 4L6  
Telephone: (780) 427-0816  
Facsimile: (780) 422- 2091  
E-mail: ed.condrotte@gov.ab.ca  
and OTHER STUDY MEMBERS to be designated.

## **PAYMENT TERMS:**

Payment will be made on receipt of invoice according to the following schedule.

20% on initial signing of contract.

20% following second interim progress meeting.

40% on completion of the draft report.

20% on acceptance of final report and presentation.

#### A.4. Bitumen Properties

PROPERTIES OF ATHABASCA BITUMEN FOLLOW:

	<b>wt%</b>
Saturates	17.3
Aromatics	39.7
Resins	25.7
Asphaltenes	17.3
Total	100.0

<b><u>Analysis</u></b>	<b><u>Athabasca Bitumen, batch 02-4.9</u></b>
Carbon, wt%	84.26
Hydrogen, wt%	9.90
H/C atomic ratio	1.4099
Nitrogen, wt%	0.36
Sulphur, wt%	4.94
Oxygen by diff., wt%	0.54
Ash, wt%	0.37
Toluene Insoluble, wt%	0.16
Pentane Insoluble, wt%	17.30
Asphaltene, wt%	17.14
Pitch (+524°C), wt%	51.00
Fe, ppm	263.8
Ni, ppm	65.4
V, ppm	192.6
Water, wt%	0.301
MCR, wt%	13
Viscosity at 40°C, cPs	26900
Viscosity at 60°C, cPs	3070
Density, g/cc at 15.6°C	1.011
Gravity, API	8.46

Figure AB-028 gives the true boiling point distillation curve of Athabasca bitumen obtained by high temperature simulated distillation.

**A.5. Process Design Drawings**  
**Figure AB-001 Executive Summary**

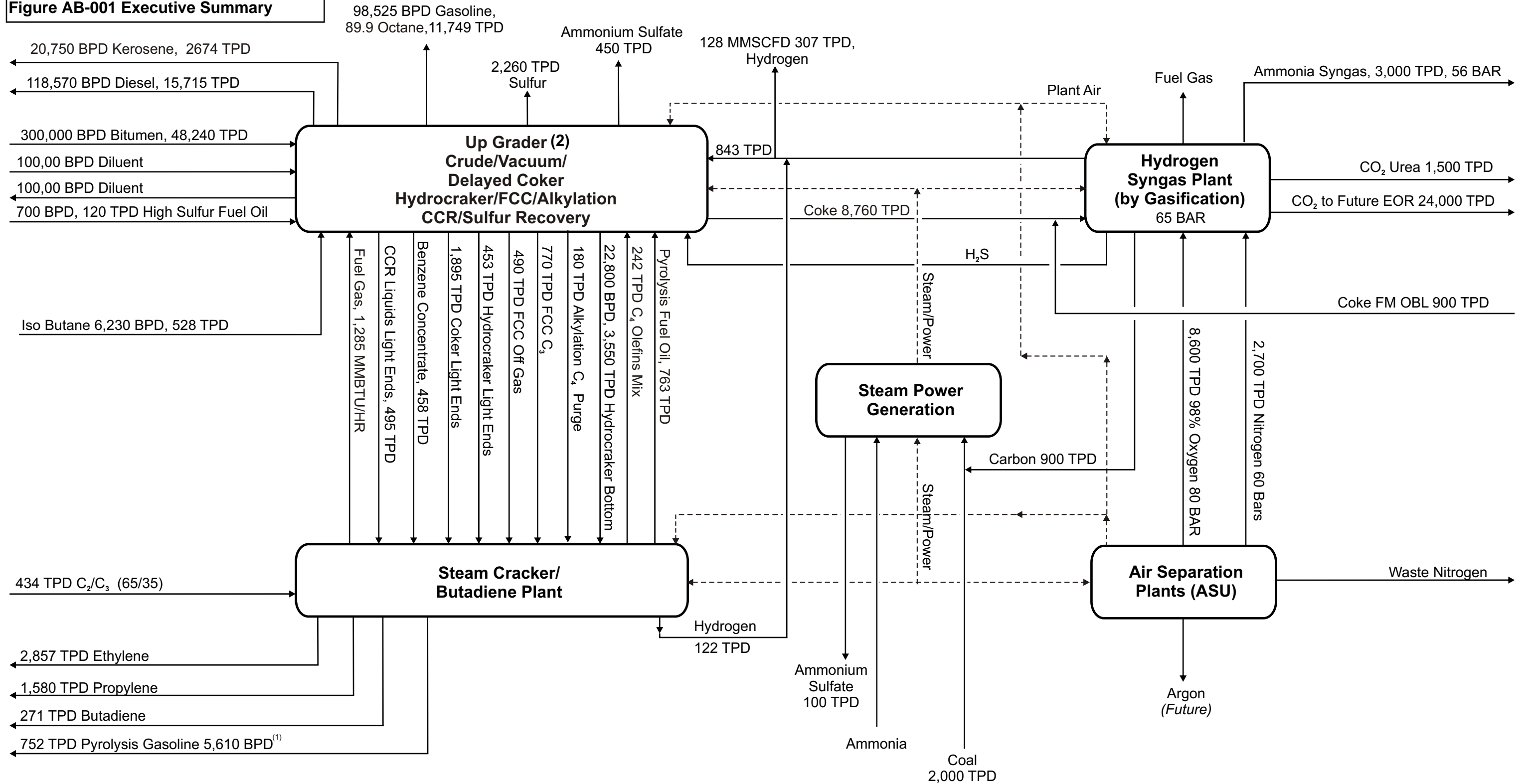

<sup>(1)</sup> Contains 72 WT % Benzene

<sup>(2)</sup> All in Metric Tons Per Day

**Figure AB-002 Bitumen Processing Integration Study Plant Overview, Sheets 1 and 2**

**SECTION 1: CONVERSION SECTION**

**SECTION 2: HYDROGEN/AMMONIA SYNGAS**

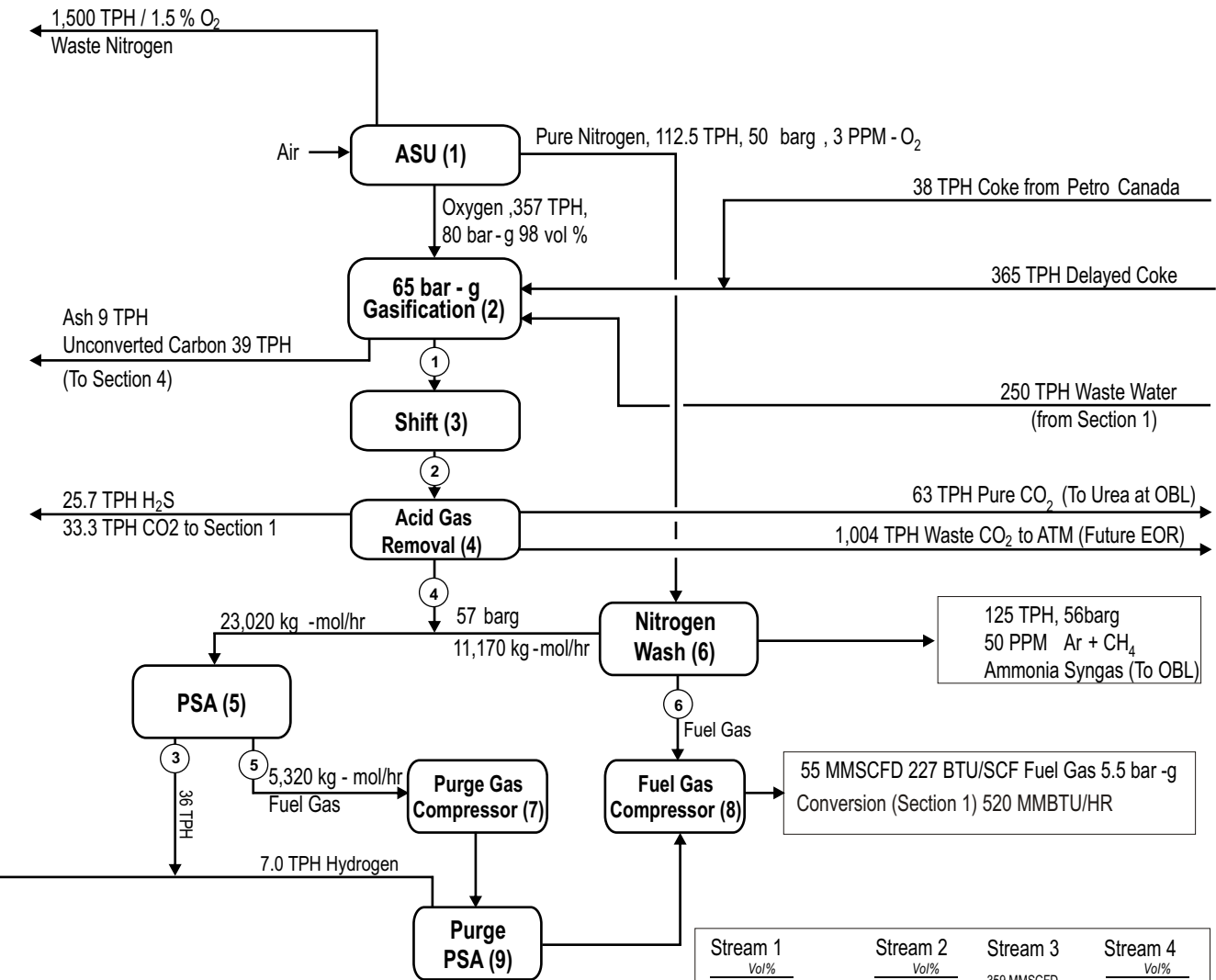
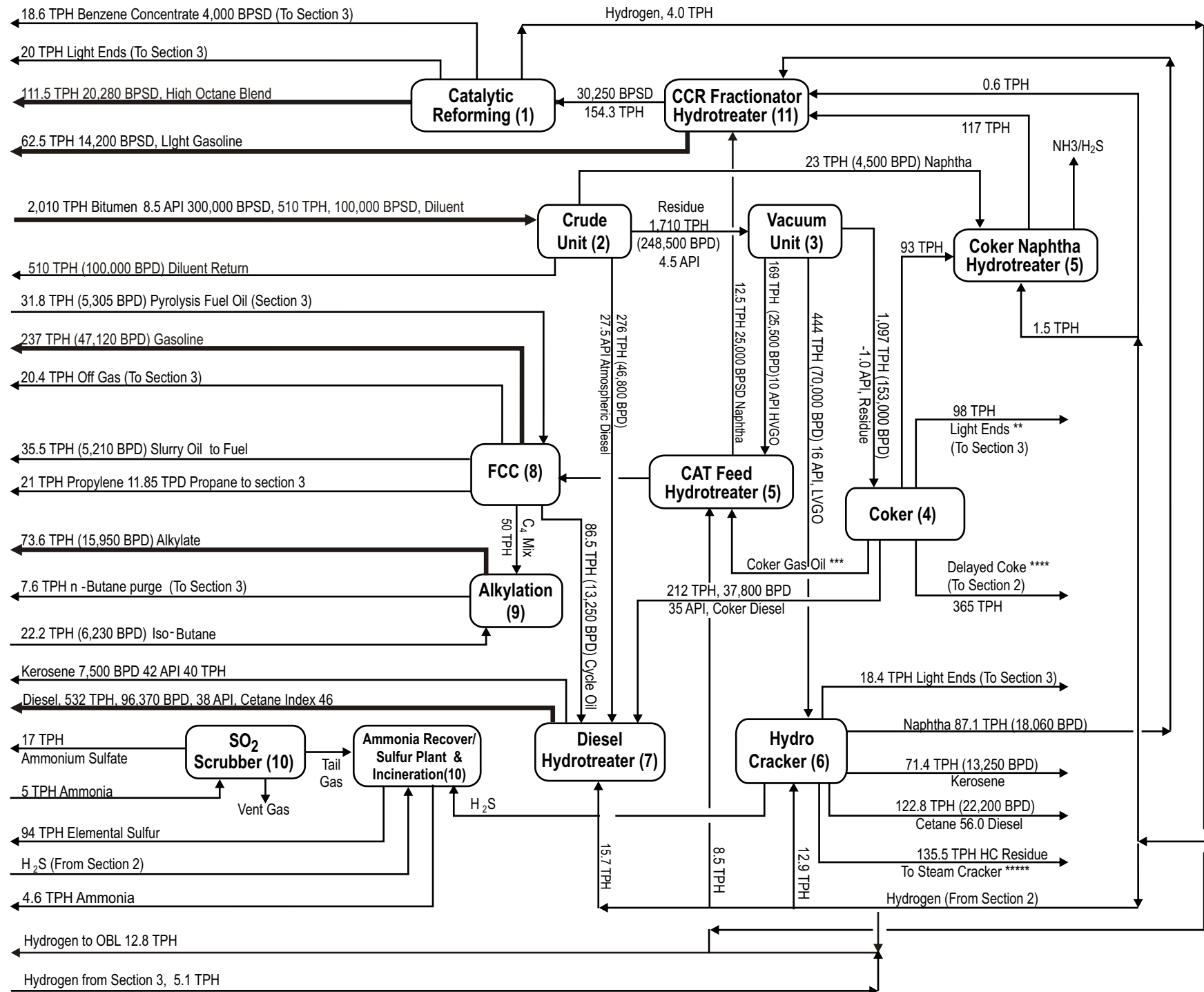

\* 1.6 wt% Sulfur  
30 wt% Olefins  
3.5 wt% di olefin

\*\* 20 wt% H<sub>2</sub>S  
2 wt% NH<sub>3</sub>  
20 wt% CH<sub>4</sub>  
58 wt% C<sub>2</sub>-C<sub>4</sub>

\*\*\* 329 TPH (49,750 BPD)  
10 API  
5.5 wt% Sulfur  
0.8 wt% Nitrogen

\*\*\*\* 365 TPH  
15,300 Btu/lb  
6.5 wt% Sulfur  
1.37 wt% Nitrogen  
3.6 wt% Hydrogen

\*\*\*\*\* 135.5 TPH (22,800 BPD)  
26 API  
17 wt% Aromatics

Stream 1	Stream 2	Stream 3	Stream 4
Vol%	Vol%		Vol%
H <sub>2</sub> - 29.11	H <sub>2</sub> - 54.46	359 MMSCFD	H <sub>2</sub> - 95.53
CO - 45.02	CO - 1.8	H <sub>2</sub> - 99.7 vol%	CO - 3.15
H <sub>2</sub> S - 1.66	CH <sub>4</sub> - 0.10	CO - 50 PPM	N <sub>2</sub> - 0.30
COS - 0.042	H <sub>2</sub> S - 1.29	Ar - 0.30 vol%	Ar - 0.66
CO <sub>2</sub> - 11.36	COS - 0.004	17,700 kg - mol/hr	CH <sub>4</sub> - 0.1
N <sub>2</sub> - 0.5	CO <sub>2</sub> - 41.72		34,190 kg - mol/hr
Ar - 0.5	N <sub>2</sub> - 0.38		
H <sub>2</sub> O - 11.71	Ar - 0.30		
(H <sub>2</sub> O - 60 vol% after quench)	59,970 kg - mol/hr		
Stream 5	Stream 6		
Vol%	Vol%		
H <sub>2</sub> - 81.50	975 kg - mol/hr		
CO - 13.8	155 Btu/ scf		
N <sub>2</sub> - 4.2	H <sub>2</sub> - 14%		
CH <sub>4</sub> - 0.66	CO - 36%		
271 Btu/scf LHV	N <sub>2</sub> - 49%		
5,320 kg - mol/hr	Ar - 1.0%		
	155 Btu/ scf LHV		

\* Includes PSA Hydrogen Recovery



SECTION 3: STEAM CRACKING

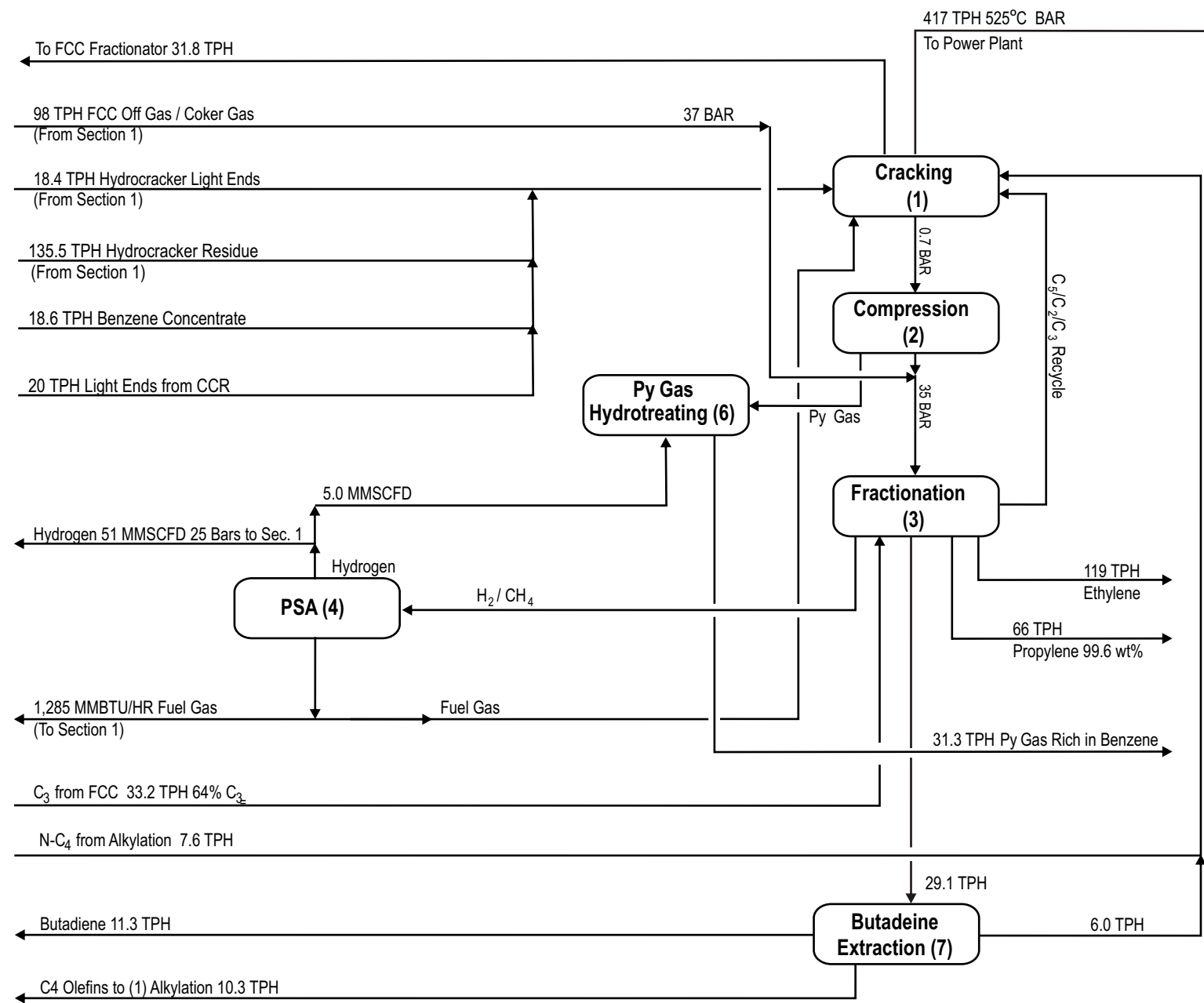

SECTION 4: POWER GENERATION

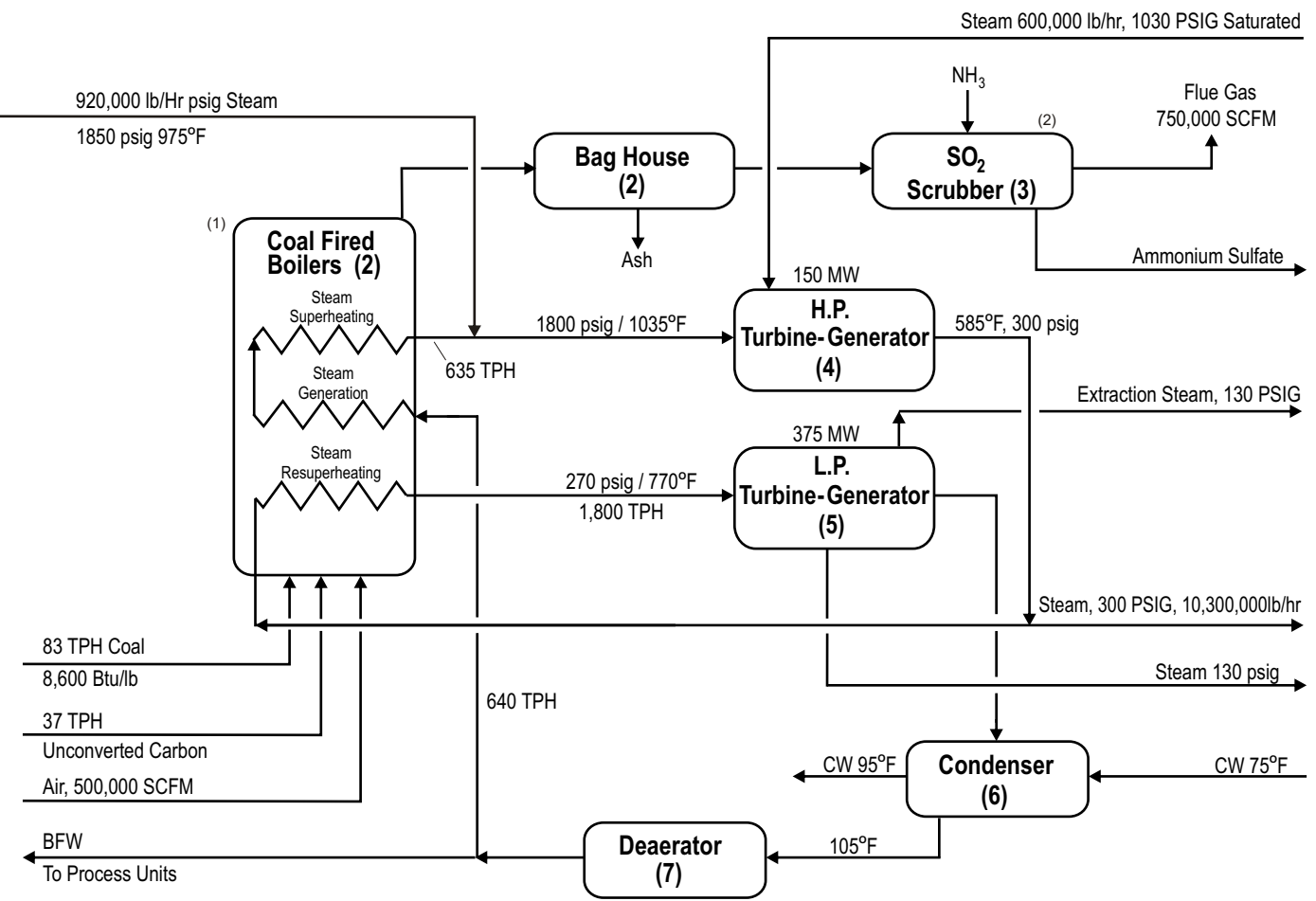

Notes

(1) Fluidized Bed Boiler

(2) Includes Oxidation to Sulfate

**Figure AB-003 Crude Distillation  
– Diluent and Diesel Recovery**

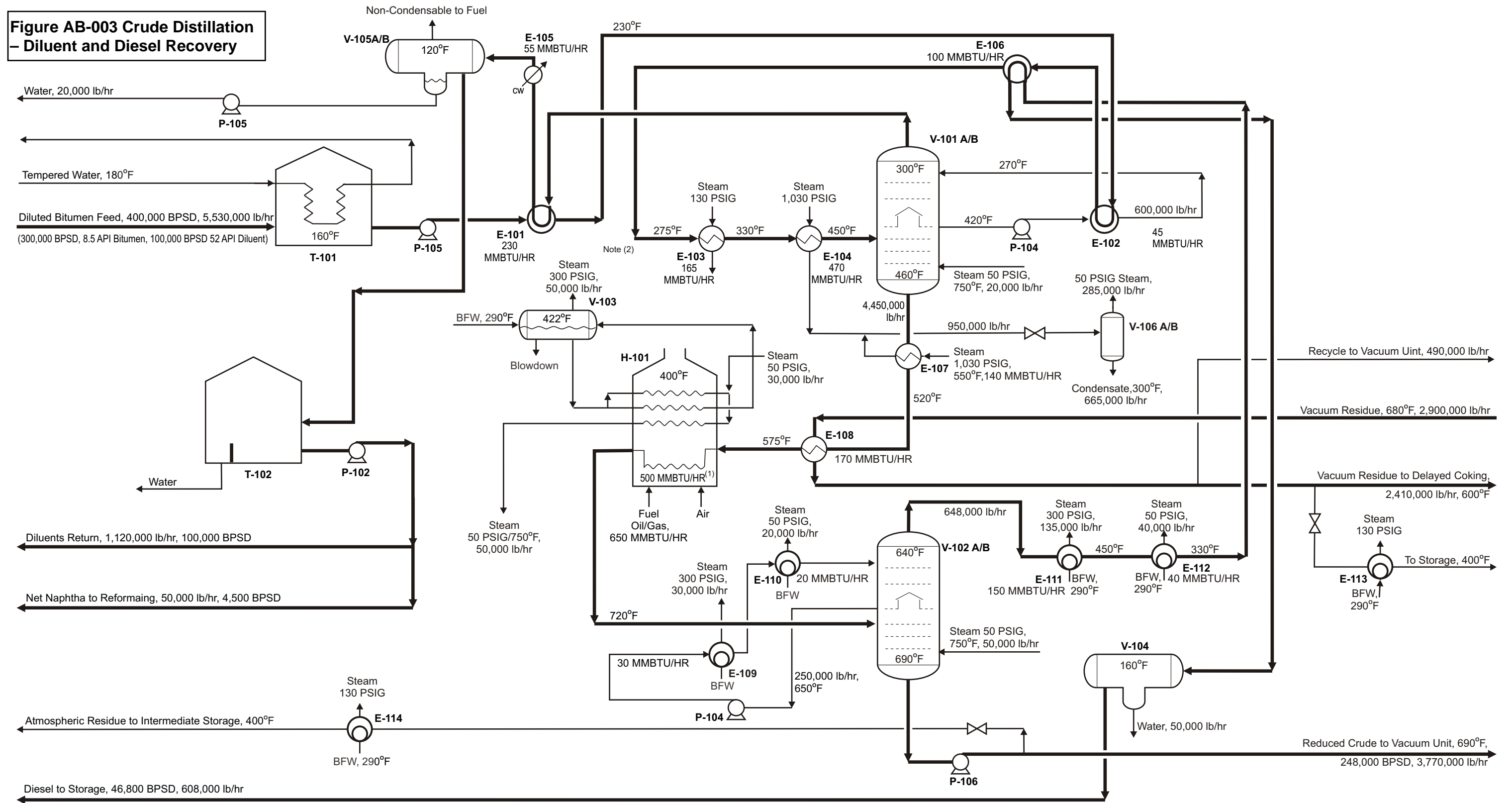

**Notes**

(1) Absorbed by process

(2) Desalter may be added at this location depending on feedstock

**T-101**

Feed Tank

**T-102**

Diluent Tank

**V-103**

Steam Drum

**V-105**

Condensate Separator

**H-101**

Diesel Column Heater

**V-101 A/B**

Naphtha Recovery Fractionator

**V-102 A/B**

Diesel Recovery Fractionator

**V-104**

Diesel Separator

January 23, 2006

AB-003

**CRUDE DISTILLATION - DILUENT AND DIESEL RECOVERY**

**ALBERTA BITUMEN PROCESSING  
INTEGRATION STUDY**

**DAVID NETZER**  
Consulting Chemical Engineer

**Figure AB-004 Vacuum Distillation**

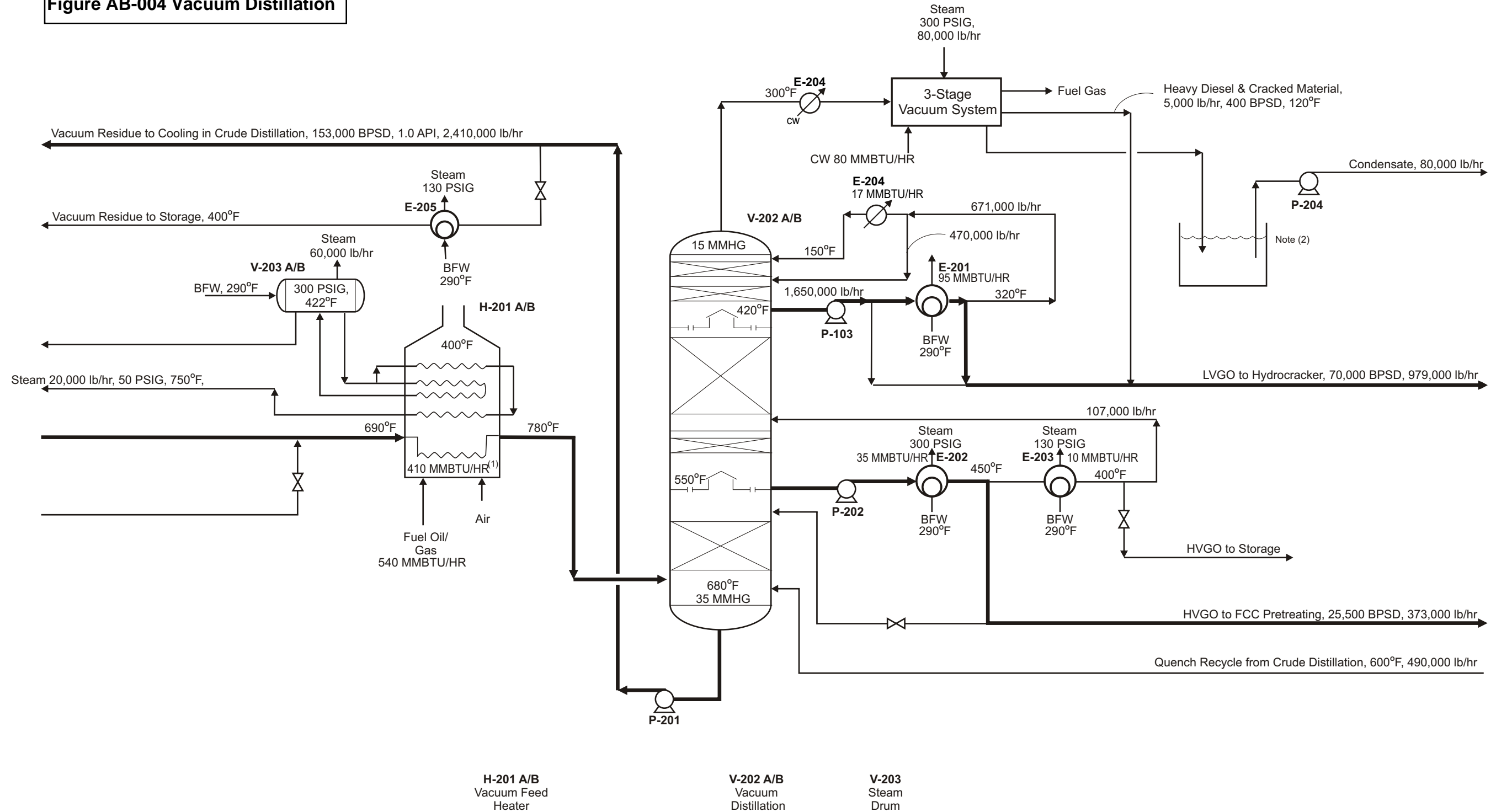

**Notes**

- (1) Absorbed by Process
- (2) Totally Enclosed Vacuum Sump

January 23, 2006 <b>AB-004</b>	<b>VACUUM DISTILLATION</b>	<b>ALBERTA BITUMEN PROCESSING          INTEGRATION STUDY</b>	<b>DAVID NETZER</b> <i>Consulting Chemical Engineer</i>
-----------------------------------	----------------------------	--	--

**Figure AB-005 Delayed Coking**

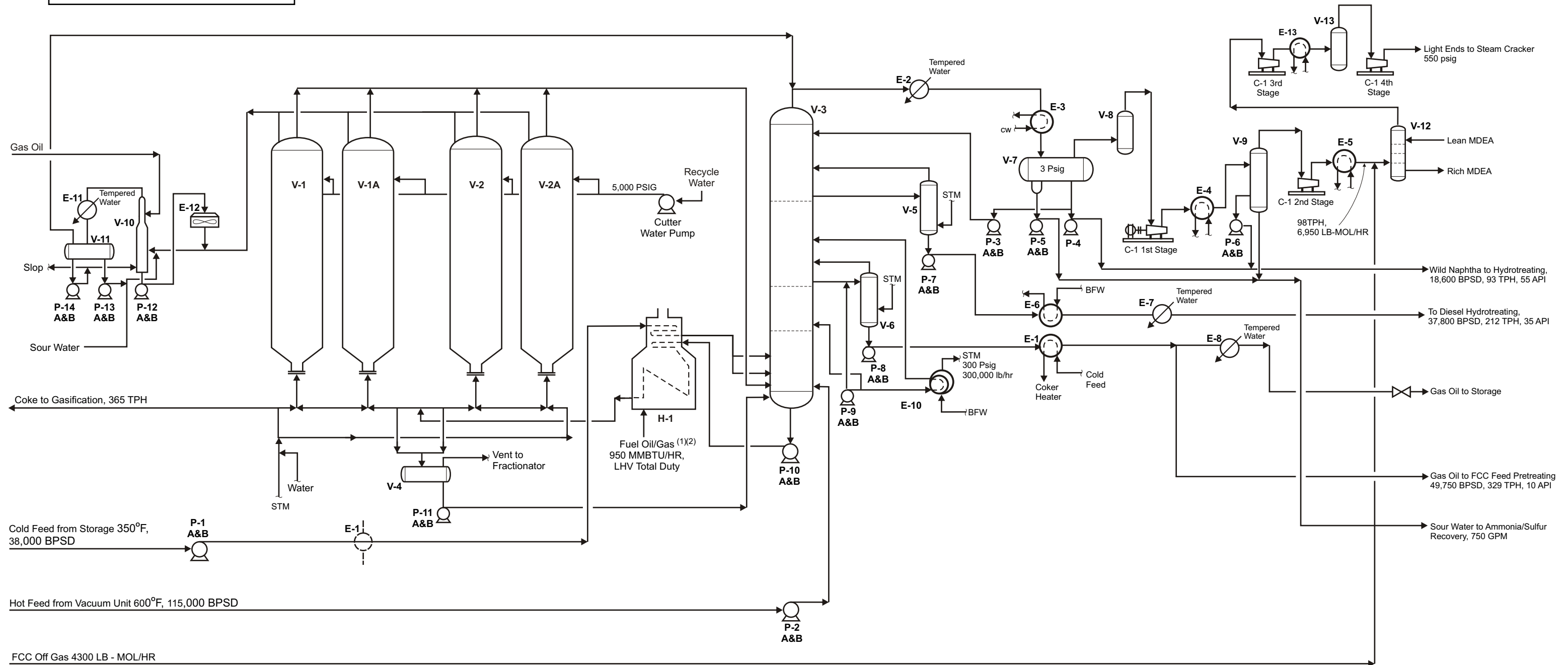

- V-10  
Blowdown  
Scrubber
- V-4  
Condensate  
Drum
- V-1 & V-1A  
Coke  
Drums
- V-2 & V-2A  
Coke  
Drums
- H-1  
Feed  
Heater
- V-3  
Main Coker  
Fractionator
- V-5  
Diesel  
Stripper
- V-6  
Gas Oil  
Stripper
- V-7  
Reflux  
Drum
- V-8  
K.O.  
Drum
- V-9  
Absorber
- V-12  
MDEA - H<sub>2</sub>S  
Removal
- V-13  
Knockout  
Drum
- C-1  
Wet Gas  
Compressor

*Note (1)*  
All Flows and Duties are Total of 2 x 80,000 BPSD Trains.

*Note (2)*  
Four Coking Drums per Train, One Heater per Drum.

**Figure AB-006 Light Vacuum Gas Oil Hydrocracking**

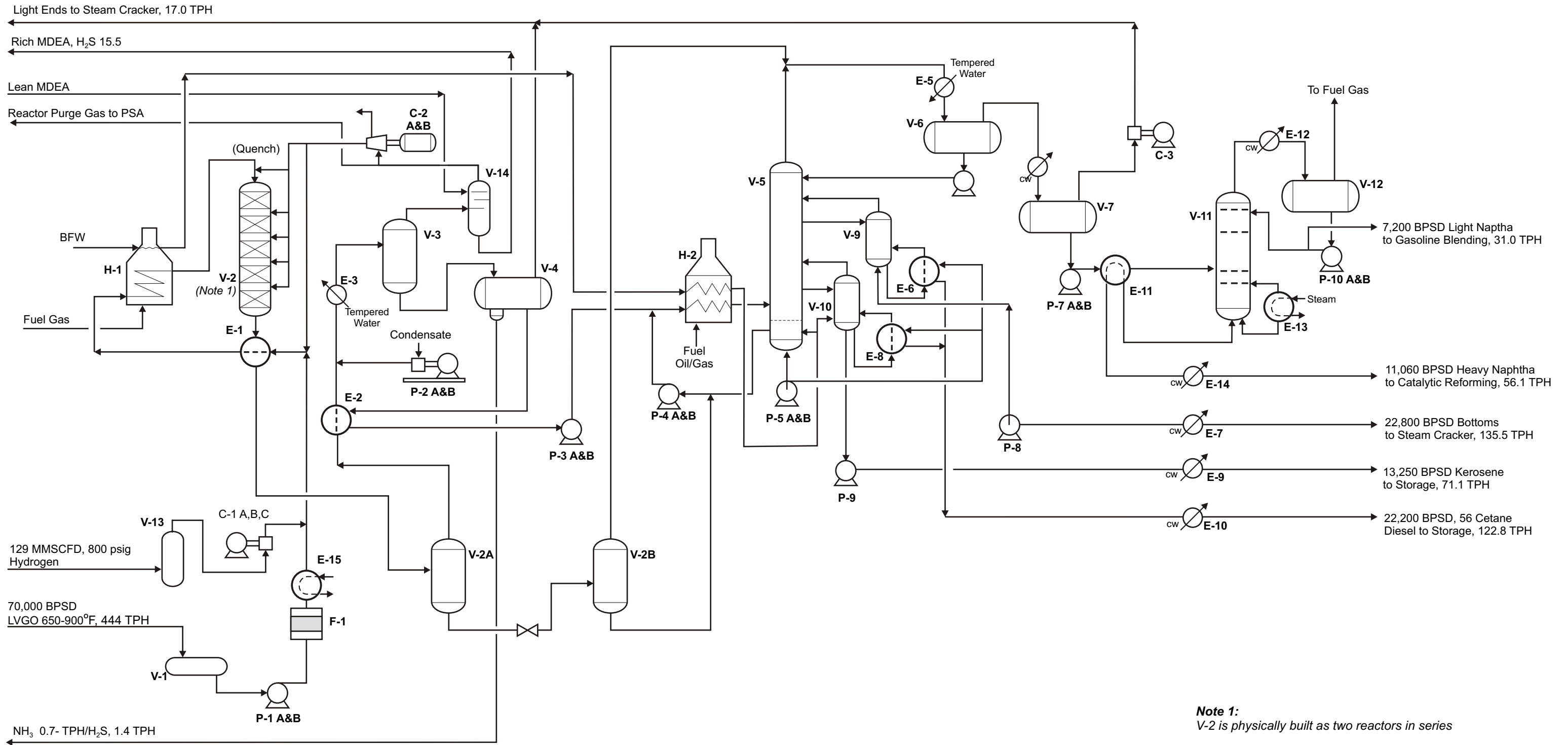

- C-1** H<sub>2</sub> Makeup Compressor
- H-1** Reactor Heater
- V-13** Make-up Gas Compressor Drum
- V-1** Feed Surge Drum
- F-1** Filter
- V-2** Reactor (Note 1)
- V-3** H.P. Cold Separator
- V-4** L.P. Cold Separator
- V-2A** H.P. Hot Separator
- V-2B** L.P. Hot Separator
- H-2** Fractionation Heater
- V-5** Splitter
- V-6** Splitter Reflux Drum
- V-7** Splitter Overhead Production Drum
- V-11** Stabilizer
- V-12** Stabilizer Reflux Drum

**Figure AB-007 FCC Feed Hydrotreater**

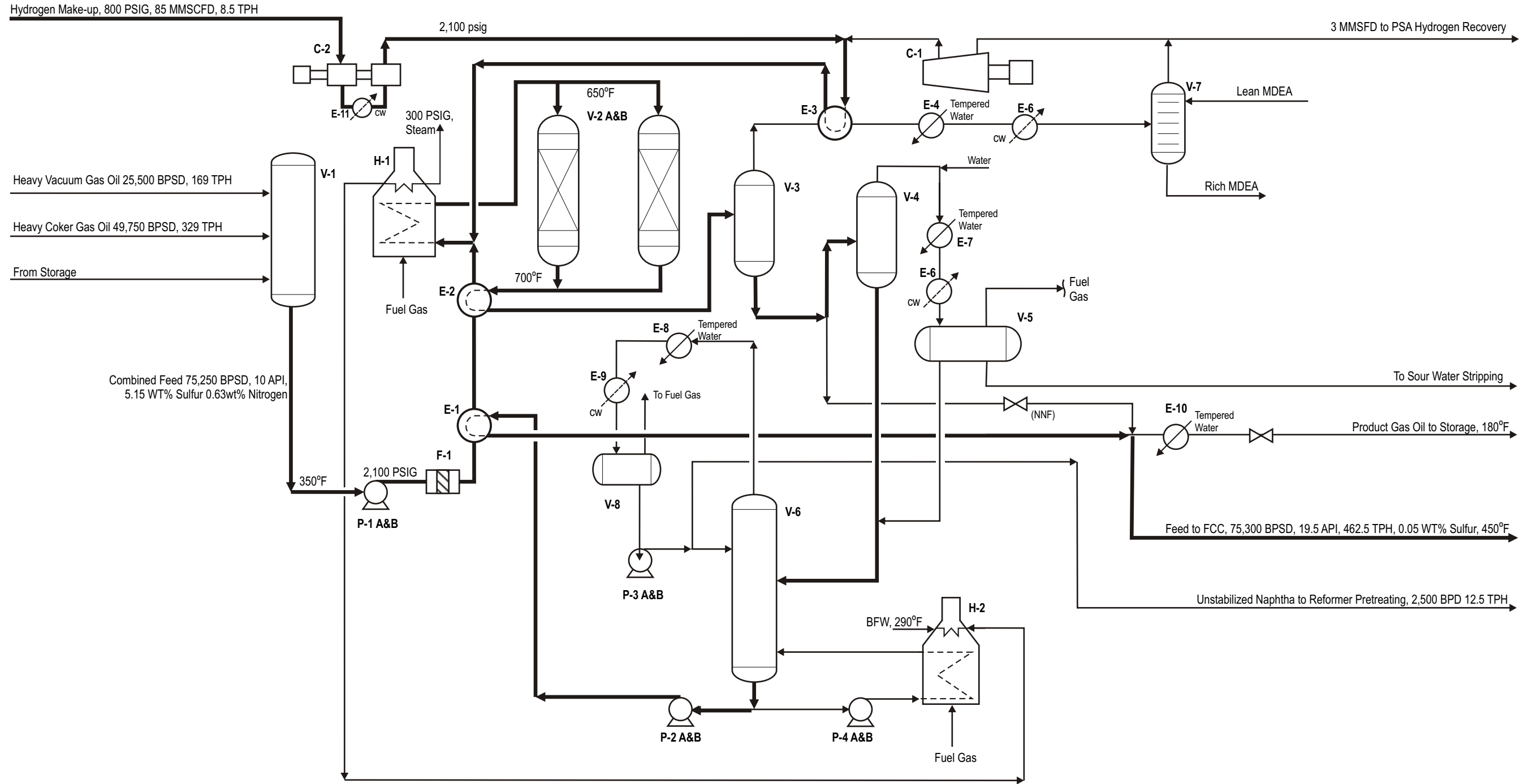

- C-1  
Recycle  
Compressor
- C-2  
Hydrogen Makeup  
Compressor
- F-1  
Filter
- V-1  
Feed Surge  
Drum
- H-1  
Heater
- V-8  
Accumulator
- V-2 A&B  
Reactors
- V-3  
High Pressure  
Separator
- V-6  
Naphtha  
Stripper
- V-4  
L.P.  
Separator
- H-2  
Heater
- V-5  
L.P. Cold  
Separator
- V-7  
H<sub>2</sub>S - Amine  
Scrubber

**Figure AB-008 Fluid Catalytic Cracking Unit  
- Converter Section, Sheet 1**

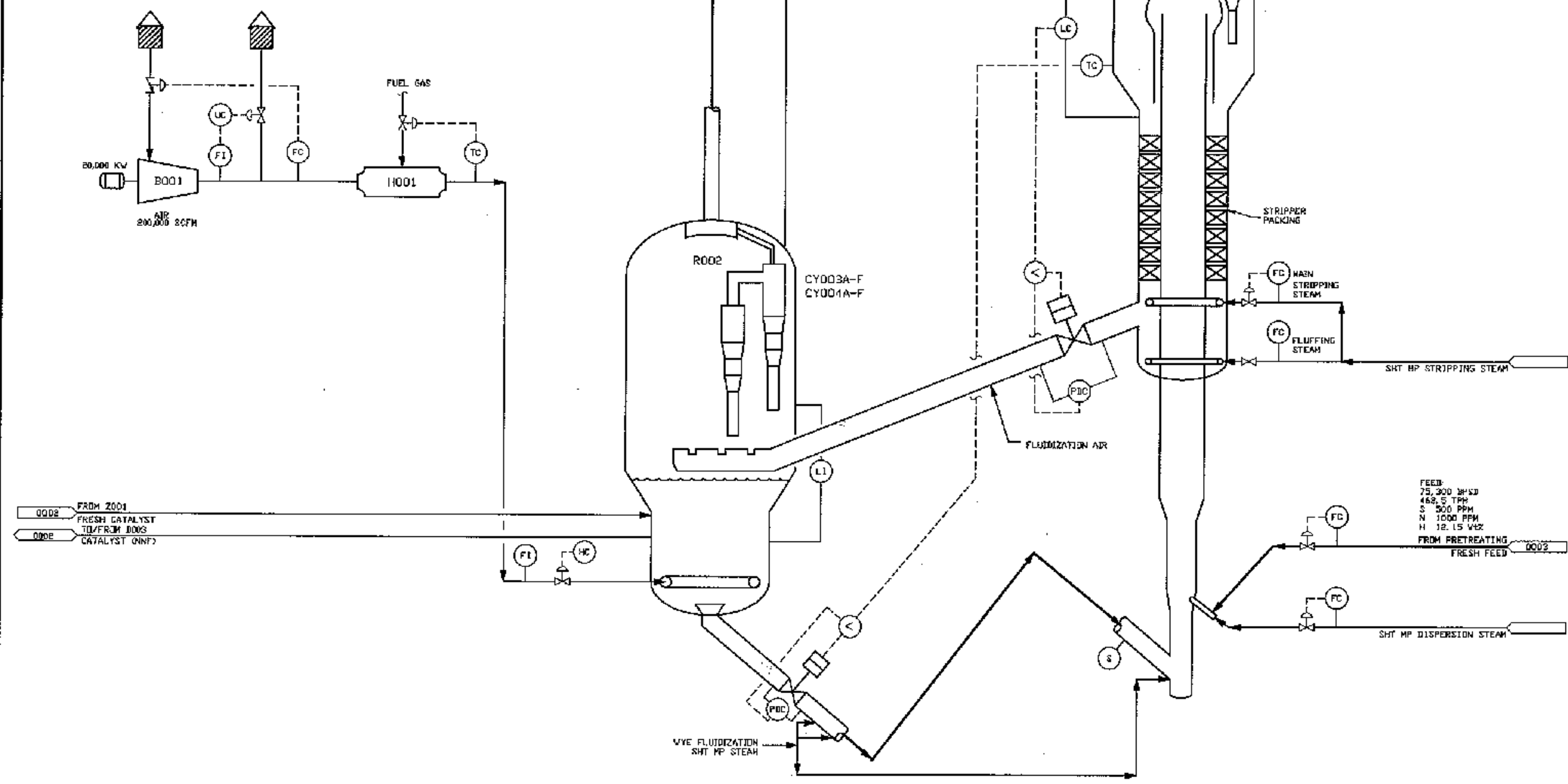

FEED:  
75,000 M<sup>3</sup>/D  
462.5 TPH  
S 500 PPM  
N 1000 PPM  
H 12.15 Wt%

SYNTHESIS UNIT - 8005251304130 - 01/09/06 1:4:23

January 23, 2006  
AB-008

B001  
AIR BLOWER

NO	DESCRIPTION OF REVISION	DATE	BY	PROJ/OWNER	PROJ	DATE
1	PRELIMINARY	04/06				

**CONFIDENTIAL**  
THIS DOCUMENT CONTAINS PROPRIETARY INFORMATION OF STONE & WEBSTER AND IS TO BE RETURNED UPON REQUEST. THIS CONFIDENTIALITY MAY NOT BE COPIED, DISCLOSED TO THIRD PARTIES, OR USED FOR OTHER THAN THE EXPRESS PURPOSE FOR WHICH IT HAS BEEN PROVIDED WITHOUT WRITTEN CONSENT OF STONE & WEBSTER.

CLIENT: CANADIAN BITUMEN UPGRADE STUDY  
TITLE: PROCESS FLOW DIAGRAM  
CONVERTER SECTION  
FLUID CATALYTIC CRACKING UNIT

REV. NO.	REV. DATE
311304130	PFD-0001
REV. NO.	REV. DATE
	P

**Figure AB-009 Fluid Catalytic Cracking Unit  
- Converter Section, Sheet 2**

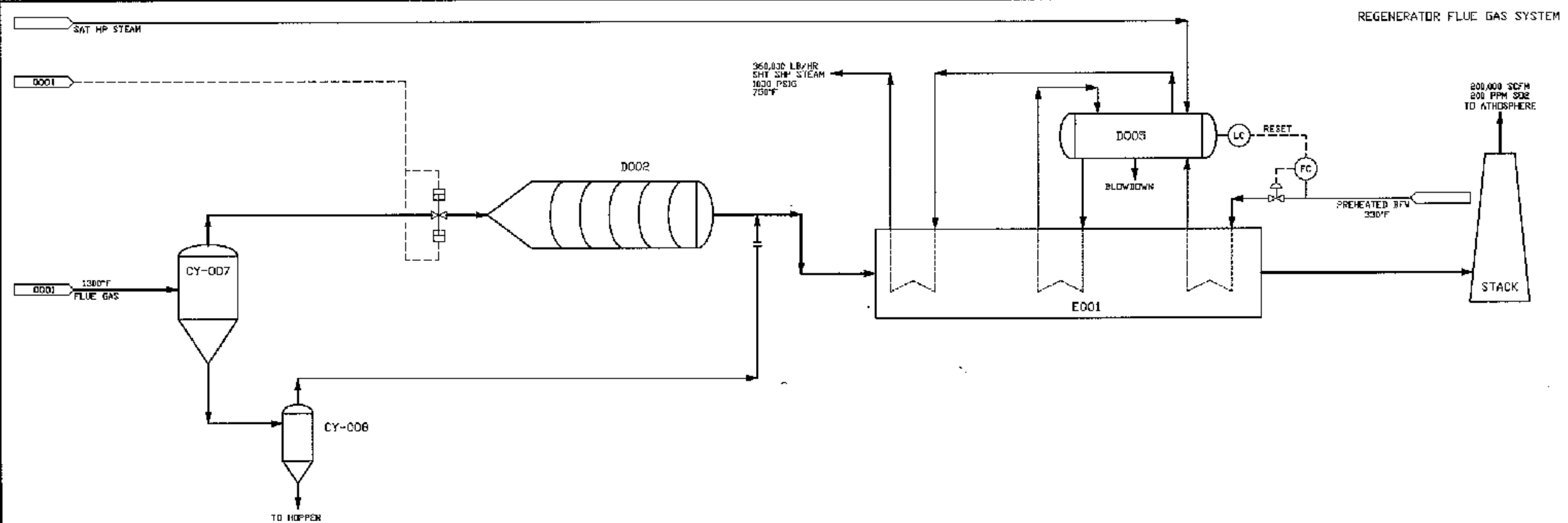
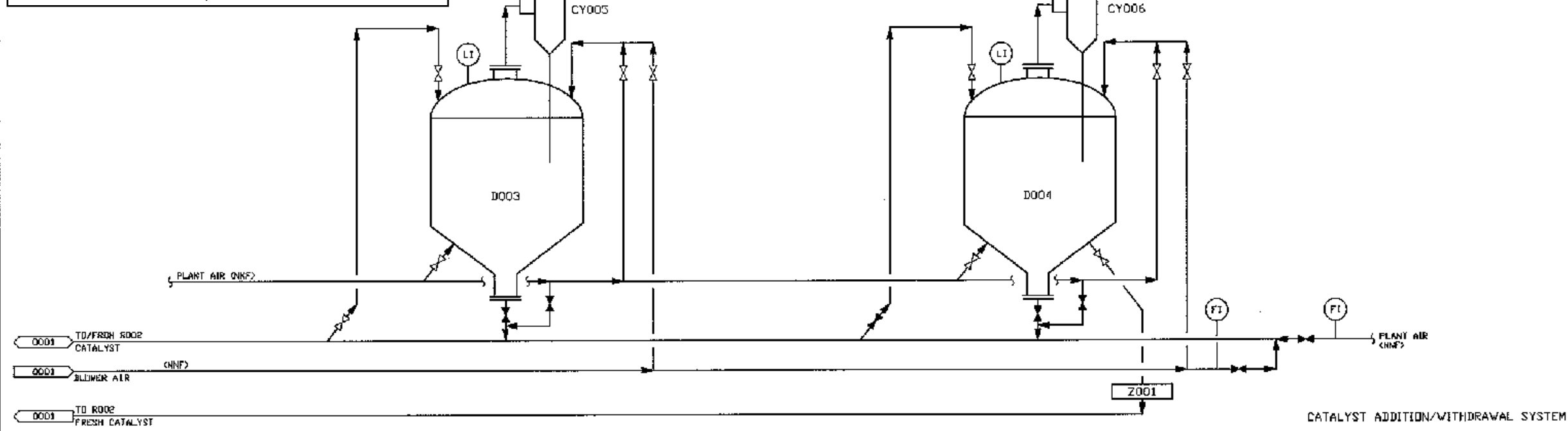

T:\PROPOSALS\WSECF\UNIT\REVISED\311304190\_3000A.PFD\002.DWG 01/09/06 13:37 (40)

January 23, 2006  
**AB-009**

NO.	DESCRIPTION OF REVISION	DATE	NO./DATE	PROJ.	CLIFF
1	PRELIMINARY	01/09/06			
<b>CONFIDENTIAL</b> <small>THIS DOCUMENT CONTAINS PROPRIETARY INFORMATION OF SHAW &amp; WEBSTER AND IS TO BE RETURNED UPON REQUEST. THE CONTENTS MAY NOT BE REPRODUCED, COPIED, OR USED FOR OTHER THAN THE EXPRESS PURPOSE FOR WHICH IT WAS SOLELY PROVIDED WITHOUT WRITTEN CONSENT OF SHAW &amp; WEBSTER.</small>					
<b>CANADIAN BITUMEN UPGRADE STUDY</b>					
<b>PROCESS FLOW DIAGRAM CONVERTER SECTION FLUID CATALYTIC CRACKING UNIT</b>					
REV. NO.	REVISED BY	REV. NO.			
311304190	PFD-0002	P			



**Figure AB-010 Fluid Catalytic Cracking Unit  
- Main Fractionator**

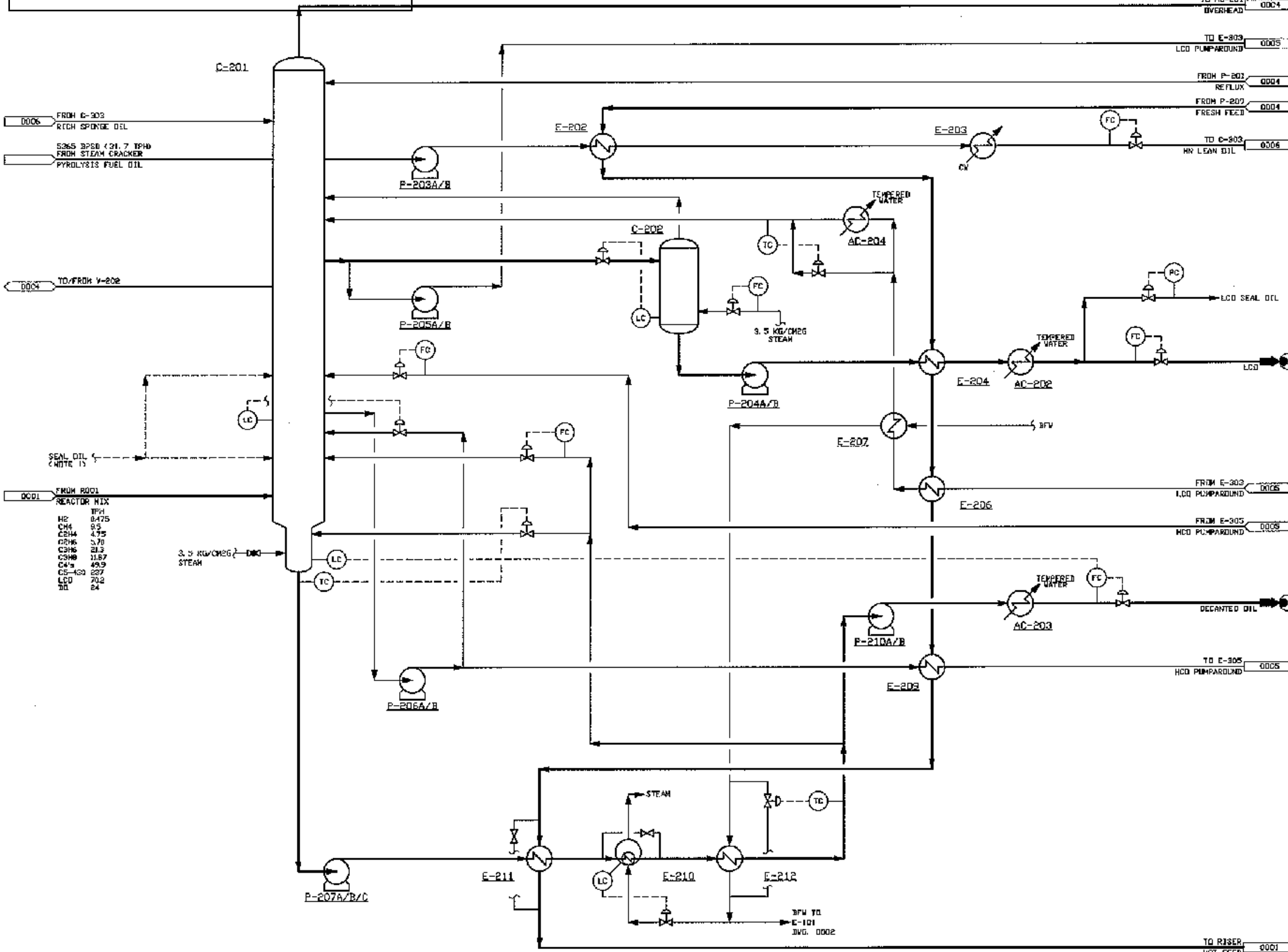

NOTES:

DATE	DESCRIPTION OF REVISION	BY	DATE	PROJECT	PSJ	DATE

CONFIDENTIAL  
THIS DOCUMENT CONTAINS PROPRIETARY INFORMATION OF STONE & WEBSTER AND IS TO BE RETURNED UPON REQUEST. ITS CONTENTS MAY NOT BE COPIED, REPRODUCED, DISSEMINATED, OR USED FOR OTHER THAN THE EXPLICIT PURPOSE FOR WHICH IT HAS BEEN PROVIDED WITHOUT WRITTEN CONSENT OF STONE & WEBSTER.

CANADIAN BITUMEN UPGRADE STUDY

PROCESS FLOW DIAGRAM  
MAIN FRACTIONATOR  
FLUID CATALYTIC CRACKING UNIT

**Shaw Stone & Webster, Inc.**

311304190	PFD-0003	P
-----------	----------	---

January 23, 2006  
AB-010

**Figure AB-011 Fluid Catalytic Cracking Unit  
– Main Fractionator Overhead**

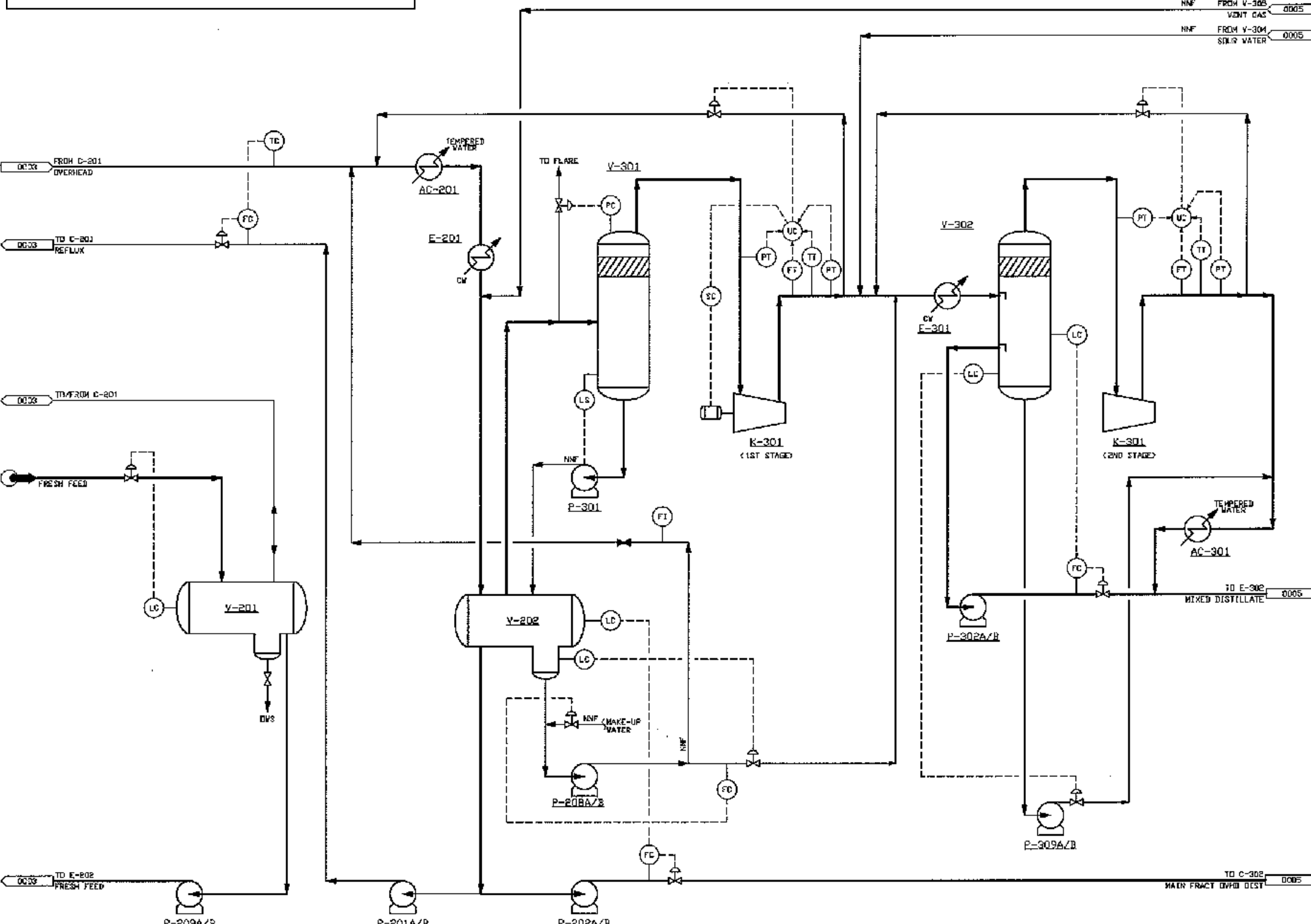

NO.	DESCRIPTION OF REVISION	DATE	PREPARED BY	PROJ.	DATE

CONFIDENTIAL

THIS DRAWING CONTAINS PROPRIETARY INFORMATION OF STONE & WEBSTER AND IS TO BE RETURNED UPON REQUEST. THE CONTENTS MAY NOT BE COPIED, REPRODUCED, OR DISSEMINATED WITHOUT THE EXPRESS PERMISSION OF STONE & WEBSTER.

CANADIAN BITUMEN UPGRADE STUDY

PROCESS FLOW DIAGRAM  
MAIN FRACTIONATOR OVERHEAD  
FLUID CATALYTIC CRACKING UNIT

	311304190	PFD-0004	P
--	-----------	----------	---

January 23, 2006  
AB-011

**Figure AB-012 Fluid Catalytic Cracking Unit  
- Absorber/Stripper & Debutanizer**

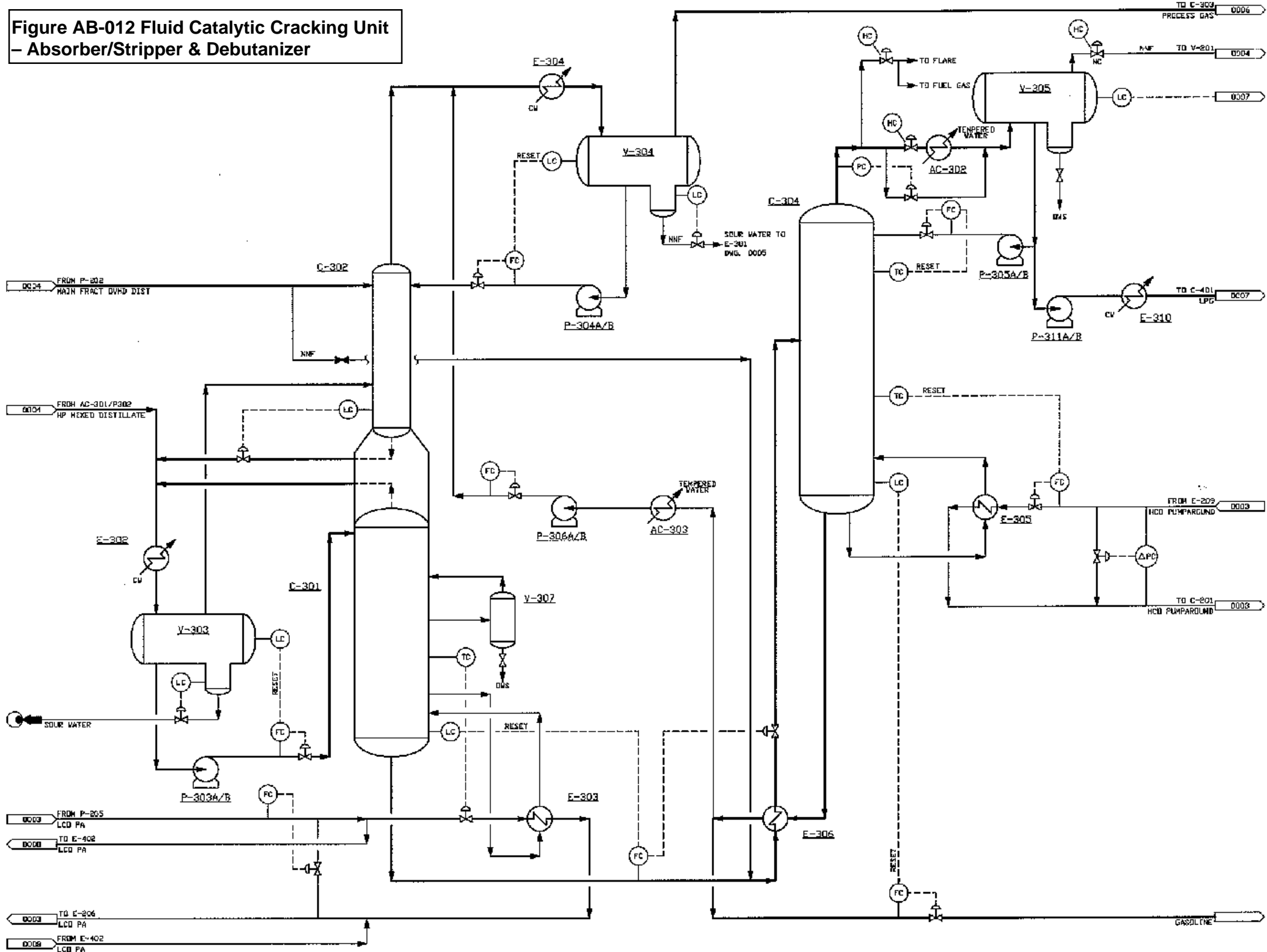

A REFINERY  
 B REGION  
 C  
 E-302 HIGH PRESSURE SEPARATOR CONDENSER  
 C-302 ABSORBER  
 V-307 STRIPPER WATER SEPARATOR DRUM  
 E-304 ABSORBER REFLUX CONDENSER  
 V-304 ABSORBER REFLEX DRUM  
 AC-303 SUPPLEMENTAL LEAN OIL AIR COOLER  
 E-306 DEBUTANIZER FEED/ BOTTOMS EXCHANGER  
 C-304 DEBUTANIZER  
 AC-302 DEBUTANIZER OVERHEAD CONDENSERS  
 E-305 DEBUTANIZER REBOILER  
 V-305 DEBUTANIZER REFLEX DRUM  
 E-310 LPG COOLER

DC24 FROM P-202 MAIN FRACT DVHD DIST  
 DC24 FROM AC-301/P302 HP HEXED DISTILLATE  
 DC26 FROM P-205 LCD PA  
 DC26 TO E-402 LCD PA  
 DC28 TO E-206 LCD PA  
 DC28 FROM E-402 LCD PA

**January 23, 2006**  
**AB-012**

P-303A/B STRIPPER FEED PUMPS  
 P-304A/B ABSORBER REFLEX PUMPS  
 P-306A/B SUPPLEMENTAL LEAN OIL RECYCLE PUMPS  
 P-305A/B DEBUTANIZER REFLEX PUMPS  
 P-311A/B DEBUTANIZER LPG PRODUCT PUMPS

NOTES:



PRELIMINARY  
 CONFIDENTIAL  
 CANADIAN BITUMEN UPGRADE STUDY  
 PROCESS FLOW DIAGRAM  
 ABSORBER/STRIPPER & DEBUTANIZER  
 FLUID CATALYTIC CRACKING UNIT  
 Stone & Webster, Inc.  
 311504190 PFD-0005

**Figure AB-013 Fluid Catalytic Cracking Unit – Sponge Absorber**

C-303  
SPONGE ABSORBER

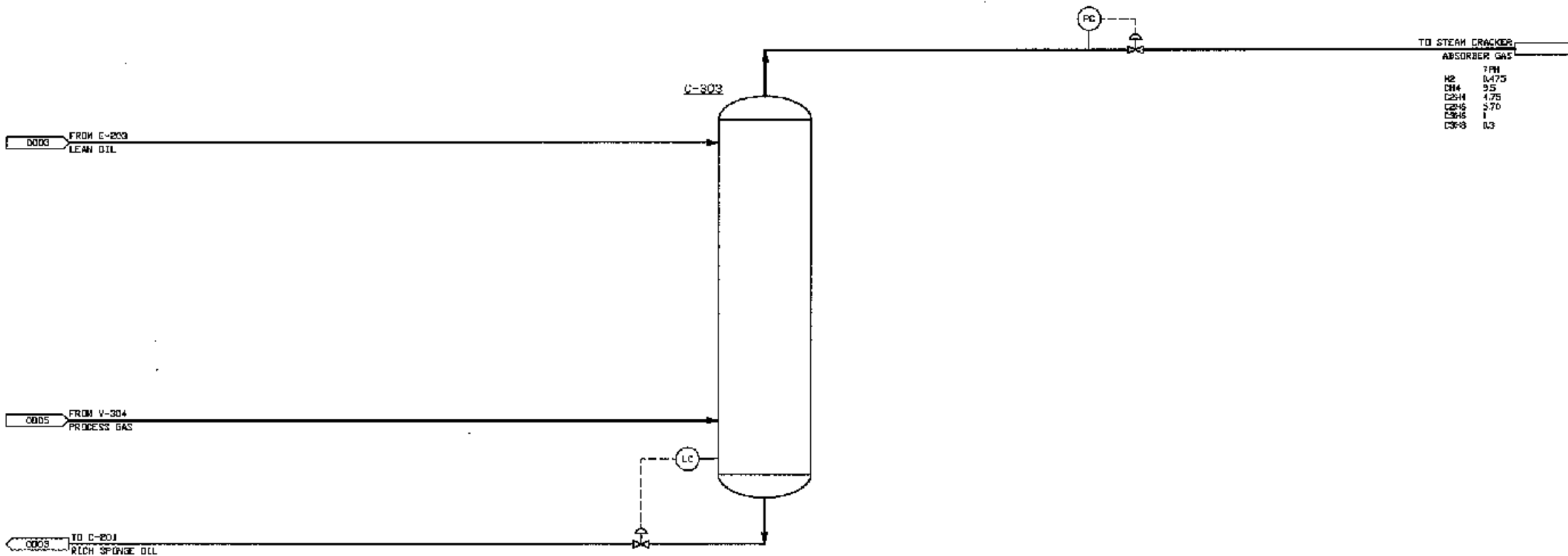

NOTES:

NO	DESCRIPTION OF REVISION	BY	DATE	PROJ/DAIR	PROJ	CONT
P	PRELIMINARY	JKV				

CONFIDENTIAL  
THIS DOCUMENT CONTAINS PROPRIETARY INFORMATION OF STONE & WEBSTER AND IS TO BE RETURNED UPON REQUEST. ITS CONTENTS MAY NOT BE COPIED, REPRODUCED OR USED FOR OTHER THAN THE EXPRESS PURPOSE FOR WHICH IT WAS PROVIDED WITHOUT WRITTEN CONSENT OF STONE & WEBSTER.

03-0007  
CANADIAN BITUMEN UPGRADE STUDY  
TITLE  
PROCESS FLOW DIAGRAM  
SPONGE ABSORBER  
FLUID CATALYTIC CRACKING UNIT

**Shaw** Stone & Webster, Inc.  
S & W U.S. MARKS  
311304190 PFD-0006 P

January 23, 2006  
AB-013

Figure AB-014 Fluid Catalytic Cracking Unit – Amine Treating

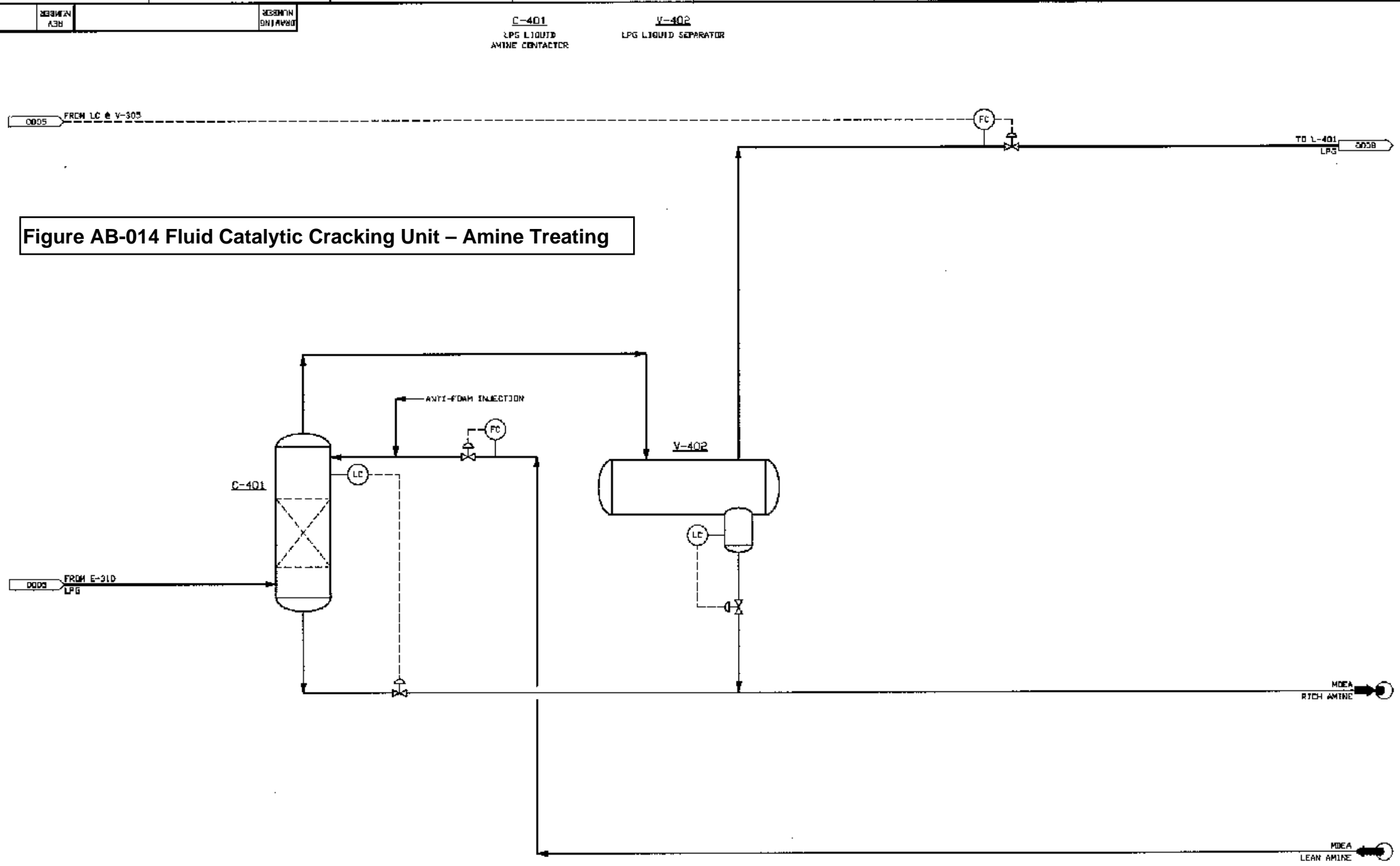

January 23, 2006  
AB-014

NOTED

P	PRELIMINARY				
NO					
CONFIDENTIAL					
THIS DOCUMENT CONTAINS PROPRIETARY INFORMATION OF STONE & WEBSTER AND IS TO BE RETURNED UPON REQUEST. IT IS NOT TO BE REPRODUCED, COPIED, OR USED FOR OTHER THAN THE EXPRESS PURPOSE FOR WHICH IT HAS BEEN PROVIDED WITHOUT WRITTEN CONSENT OF STONE & WEBSTER.					
CLIENT CANADIAN BITUMEN UPGRADE STUDY					
TITLE PROCESS FLOW DIAGRAM AMINE TREATING					
311304180	PFD-0007				

Figure AB-015 Fluid Catalytic Cracking Unit – C3/C4 Splitter

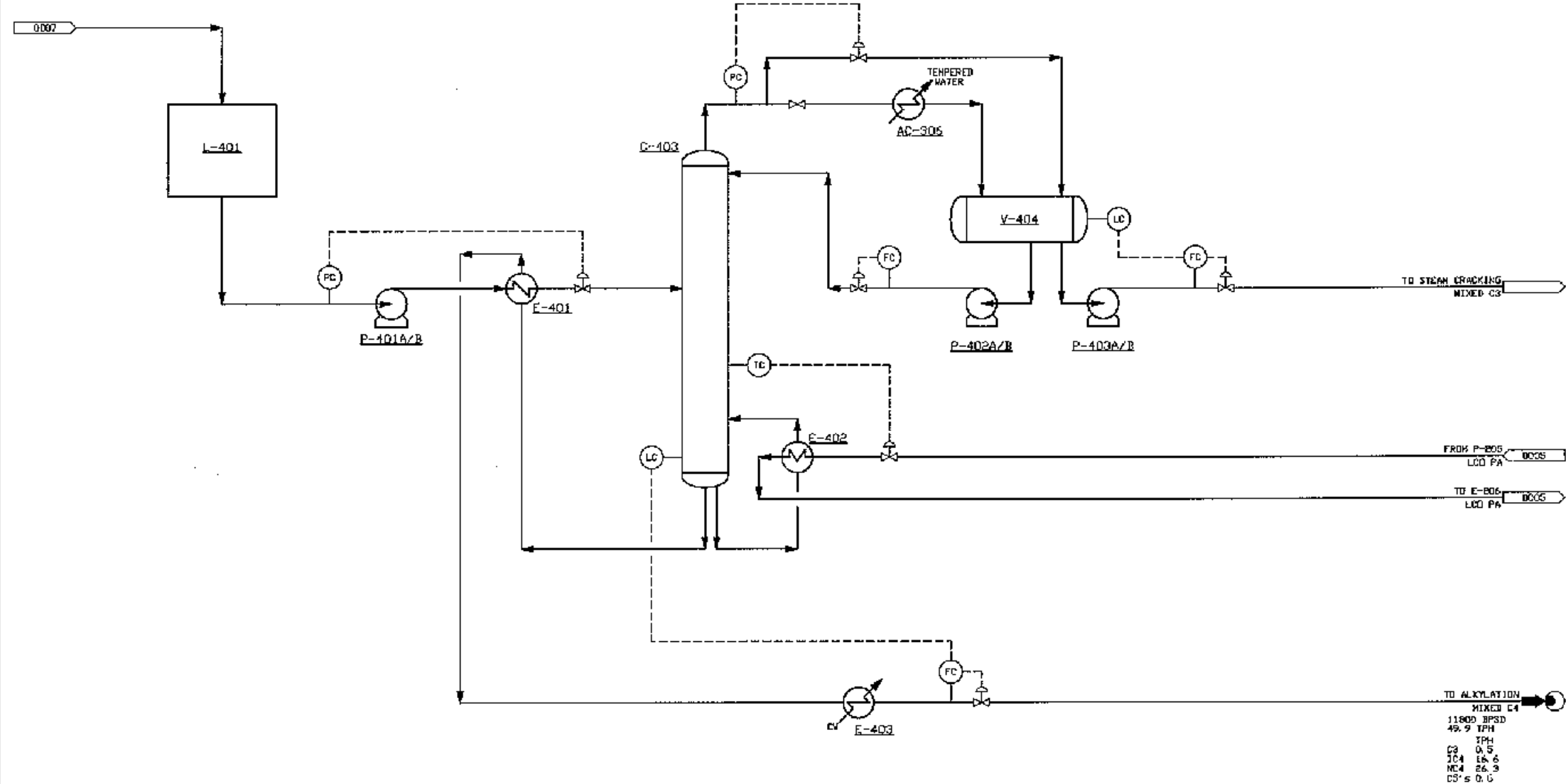

P-401A/B C3/C4 SPLITTER FEED PUMPS  
 P-402A/B C3/C4 SPLITTER REFLUX PUMPS  
 P-403A/B C3 PRODUCT PUMPS

January 23, 2006  
 AB-015

NOTES:

NO	DESCRIPTION	DATE	BY	REV	CHK
F	PRELIMINARY	GAD			
NO	DESCRIPTION	DATE	BY	REV	CHK

CONFIDENTIAL  
 THIS DOCUMENT CONTAINS PROPRIETARY INFORMATION OF SHAW & WEBSTER AND IS TO BE RETURNED UPON REQUEST. THE REVISIONS MAY NOT BE APPLIED, SUBSTITUTED OR CHANGED WITHOUT THE WRITTEN APPROVAL OF SHAW & WEBSTER. FOR COMPLETE PURPOSES FOR WORKS BY THE ABOVE PROPRIETORS WITHOUT VIOLATION OF TRADE & INTELLECTUAL

CANADIAN BITUMEN UPGRADE STUDY  
 TITLE  
 PROCESS FLOW DIAGRAM  
 C3/C4 SPLITTER



311304180 PFD-0008 P

**Figure AB-016 Catalytic Reforming**

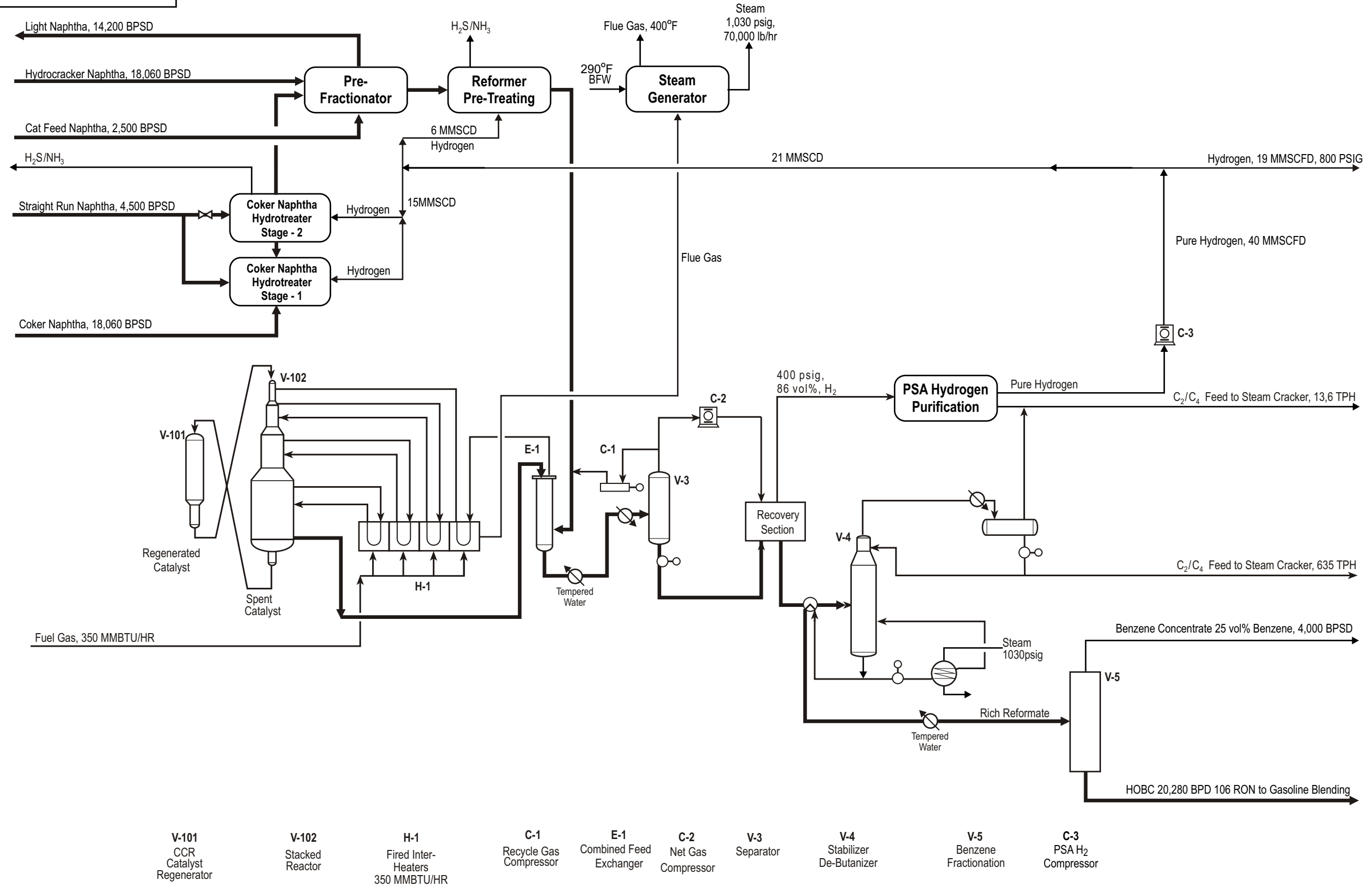

**Figure AB-017 Alkylene™ Solid Acid Alkylation**

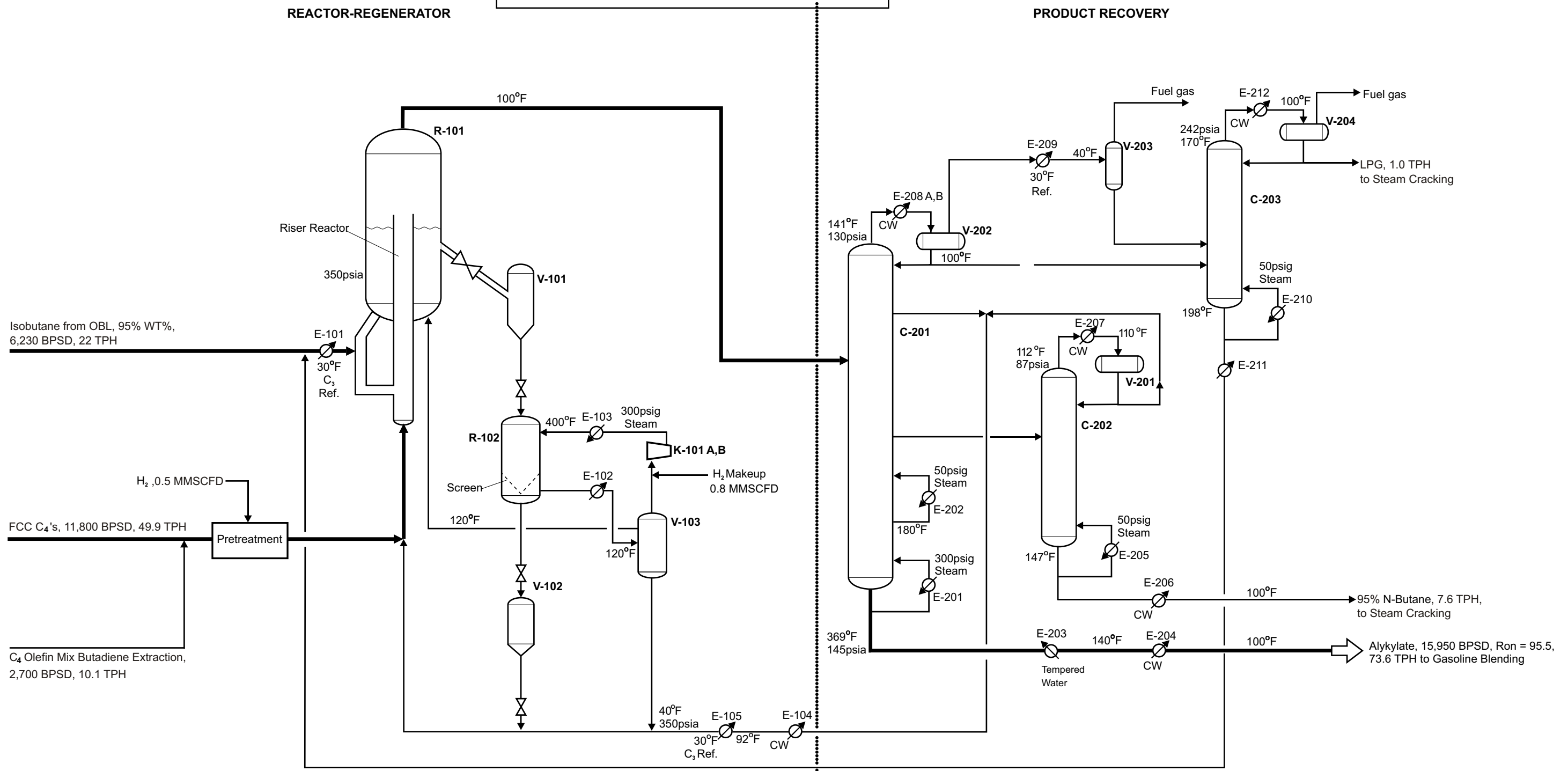

- |                                       |   |  |   |   |  |                                |   |                              |   |
|---------------------------------------|---|--|---|---|--|--------------------------------|---|------------------------------|---|
| <b>R-101</b><br>Alkylation<br>Reactor | <b>V-101</b><br>Wet Catalyst<br>Lock Hopper | <b>V-102</b><br>Regenerated<br>Catalyst<br>Lock Hopper | <b>K-101A,B</b><br>H <sub>2</sub> Recycle<br>Compressor | <b>V-103</b><br>Compressor<br>Suction<br>Drum | <b>C-201</b><br>Alkylate<br>Fractionator       | <b>C-202</b><br>Deisobutanizer | <b>V-203</b><br>H <sub>2</sub> /C <sub>4</sub><br>K.O. Drum | <b>C-203</b><br>Depropanizer | <b>V-204</b><br>Depropanizer<br>Reflux Drum |
|                                       | <b>R-102</b><br>Catalyst<br>Regenerator     |  |   |   | <b>V-202</b><br>Fractionator<br>Reflux<br>Drum |                                | <b>V-201</b><br>Deisobutanizer<br>Reflux Drum               |                              |   |



**Figure AB-018 Aromatic Saturation of Diesel via Two-Stage Hydrotreating**

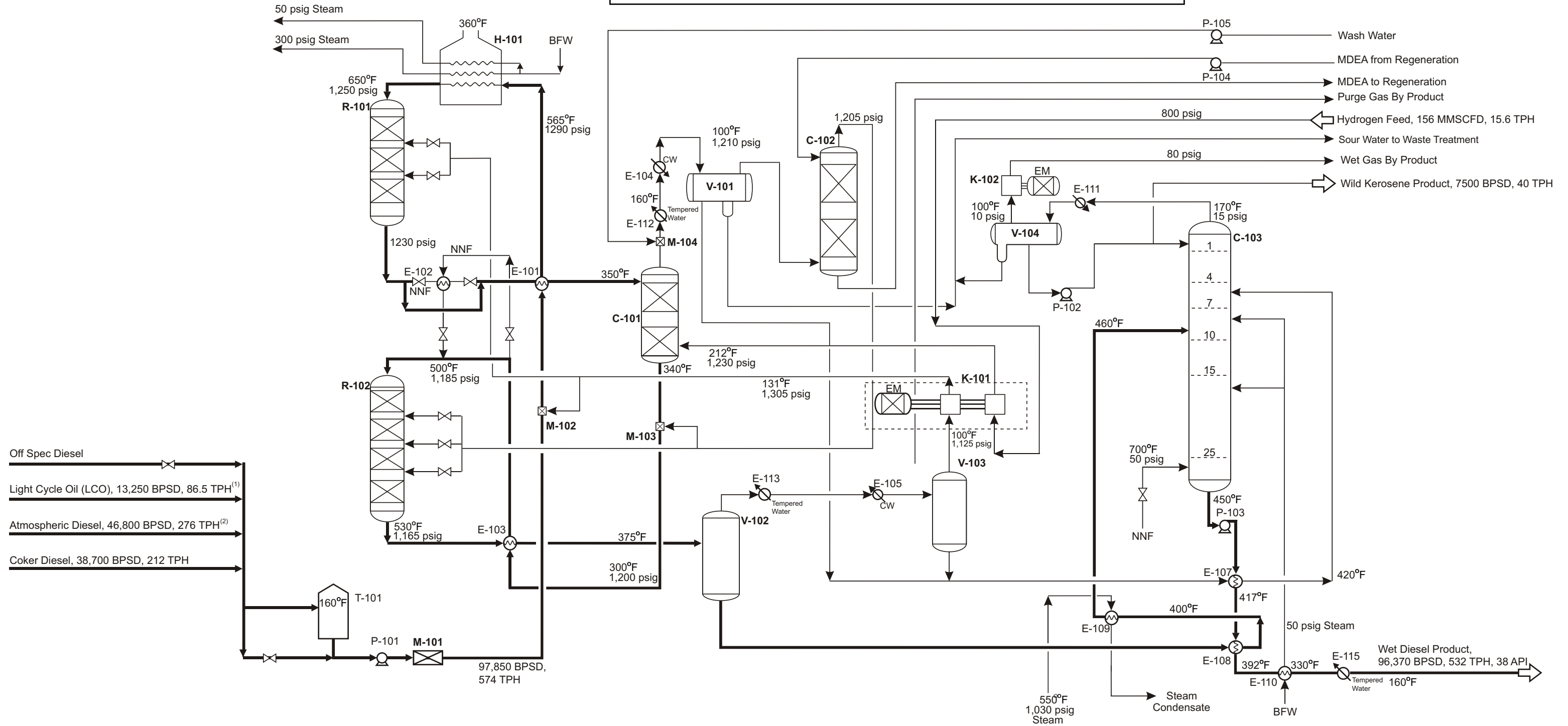

(1) Include 2,500 BPSD Pyrolysis Fuel Oil

(2) Include 5,100 BPSD Atmospheric Kerosene

			<b>H-101</b> Charge Heater		<b>M-104</b> Spray Nozzle		<b>V-101</b> HDS Cold Separator		<b>V-103</b> HDA Cold Separator	<b>K-101</b> H <sub>2</sub> Makeup/Recycle Compressor		
<b>T-101</b> Feed Surge Tank	<b>R-101</b> HDS Reactor	<b>R-102</b> HDA Reactor	<b>M-101</b> Filter	<b>M-102</b> Mixing Nozzle	<b>C-101</b> HDS Stripper	<b>M-103</b> Mixing Nozzle	<b>V-102</b> HDA Hot Separator	<b>C-102</b> H <sub>2</sub> S Absorber	<b>V-104</b> Reflux Drum	<b>K-102</b> Wet Gas Compressor		<b>C-103</b> Diesel Stripper

**Figure AB-019 Sulphur Recovery**

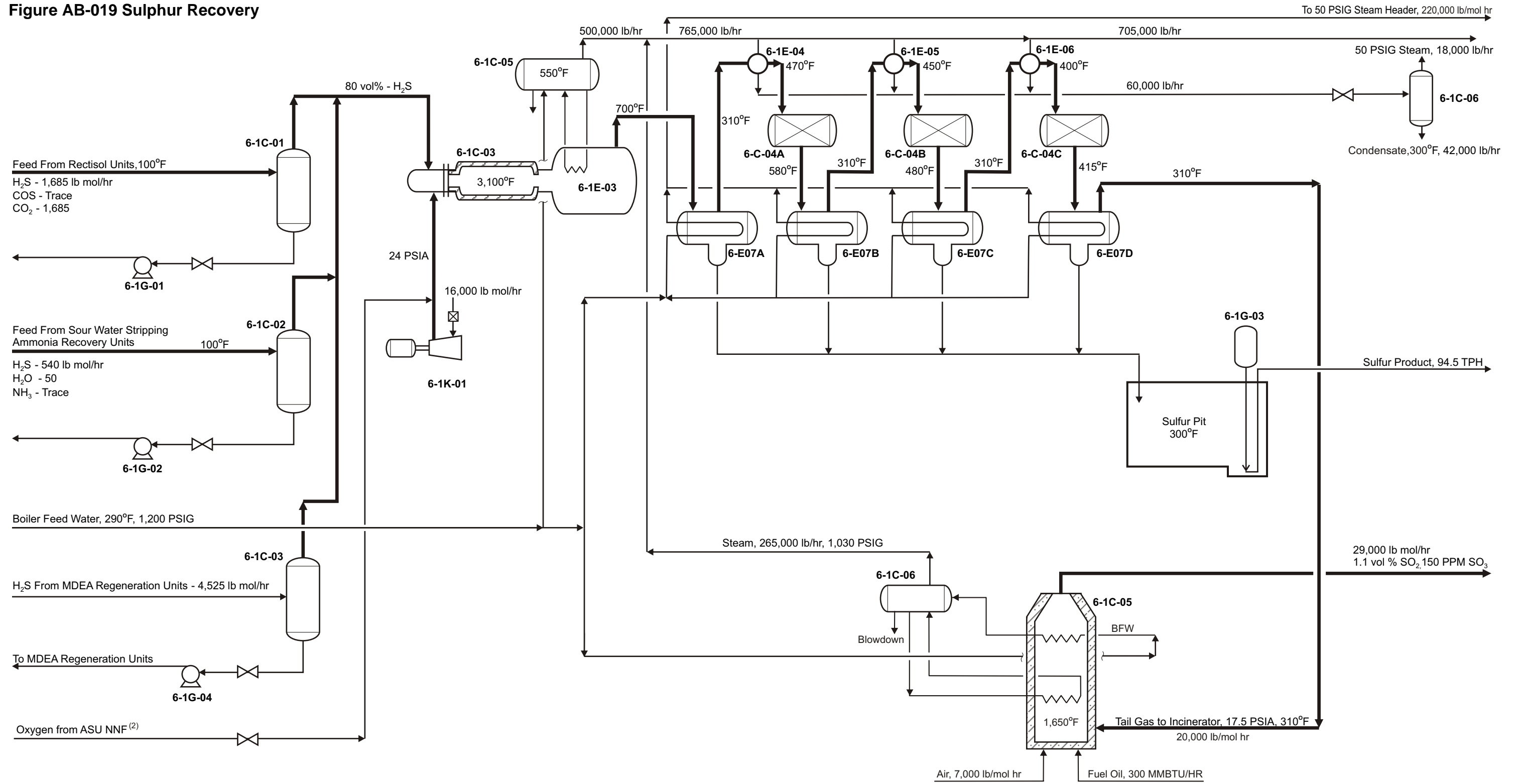

- 6-1G-01  
Feed Separator  
Pump
- 6-1G-02  
SHS Feed  
Separator  
Pump
- 6-1C-01  
Feed Separator
- 6-1C-02  
Sour Water  
Stripper Feed  
Separator
- 6-1E-03  
Waste Heat  
Boiler
- 6-1C-04  
Thermal Reactor
- 6-1E-04  
Catalytic  
Reactor
- 6-1C-05  
Catalytic  
Reactor
- 6-1E-05  
Second Stage  
Reheat
- 6-1E-06  
Third Stage  
Reheat
- 6-1E-07  
Sulfur  
Condenser
- 6-1G-03  
Molten Sulfur  
Pump
- 6-1C-06  
Condensate  
Flush  
Drum
- 6-1K-01  
Reactor Combustion  
Air Blower
- 6-1C-05  
Steam  
Drum
- 6-1C-05  
Incinerator

**Notes**  
 (1) Two Units of 65% Capacity each Operating at 75%  
 (2) Oxygen Enrichment when One SRU is Down

January 23, 2006 <b>AB-019</b>	<b>SULFUR RECOVERY</b>	<b>ALBERTA BITUMEN PROCESSING INTEGRATION STUDY</b>	<b>DAVID NETZER</b> <i>Consulting Chemical Engineer</i>
-----------------------------------	------------------------	---	--

**Figure AB-020 Delayed Coke Gasification**

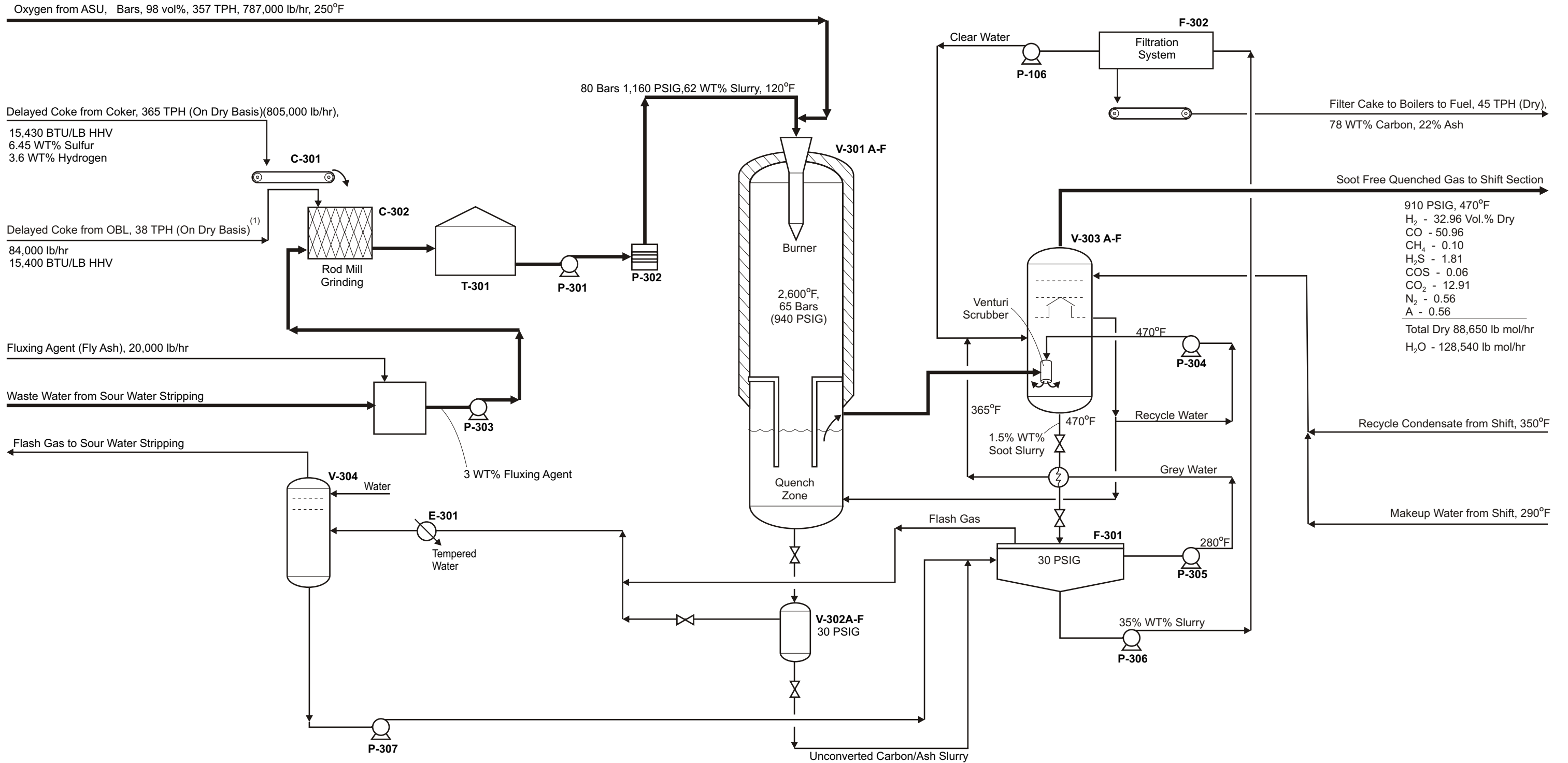

- C-302  
Rod Mill  
Grinder
- T-301  
Coke Slurry  
Tank
- P-303  
Coke Slurry  
Booster Pump
- P-307  
Coke Slurry  
Booster Pump
- P-301  
Coke Slurry  
Pump
- P-302  
Coke Slurry  
Pump
- V-301 A-F  
Gasifiers
- V-302A-F  
Lock  
Hopper
- F-302  
Filtration  
System
- F-301  
Soot  
Settler
- V-303 A-F  
Soot  
Scrubbers

**Notes**

(1) By Trucks or Rail Cars

January 23, 2006 <b>AB-020</b>	<b>DELAYED COKE GASIFICATION</b>	<b>ALBERTA BITUMEN PROCESSING INTEGRATION STUDY</b>	<b>DAVID NETZER</b> <i>Consulting Chemical Engineer</i>
-----------------------------------	----------------------------------	---	--

**Figure AB-021 Shift and Gas Cooling**

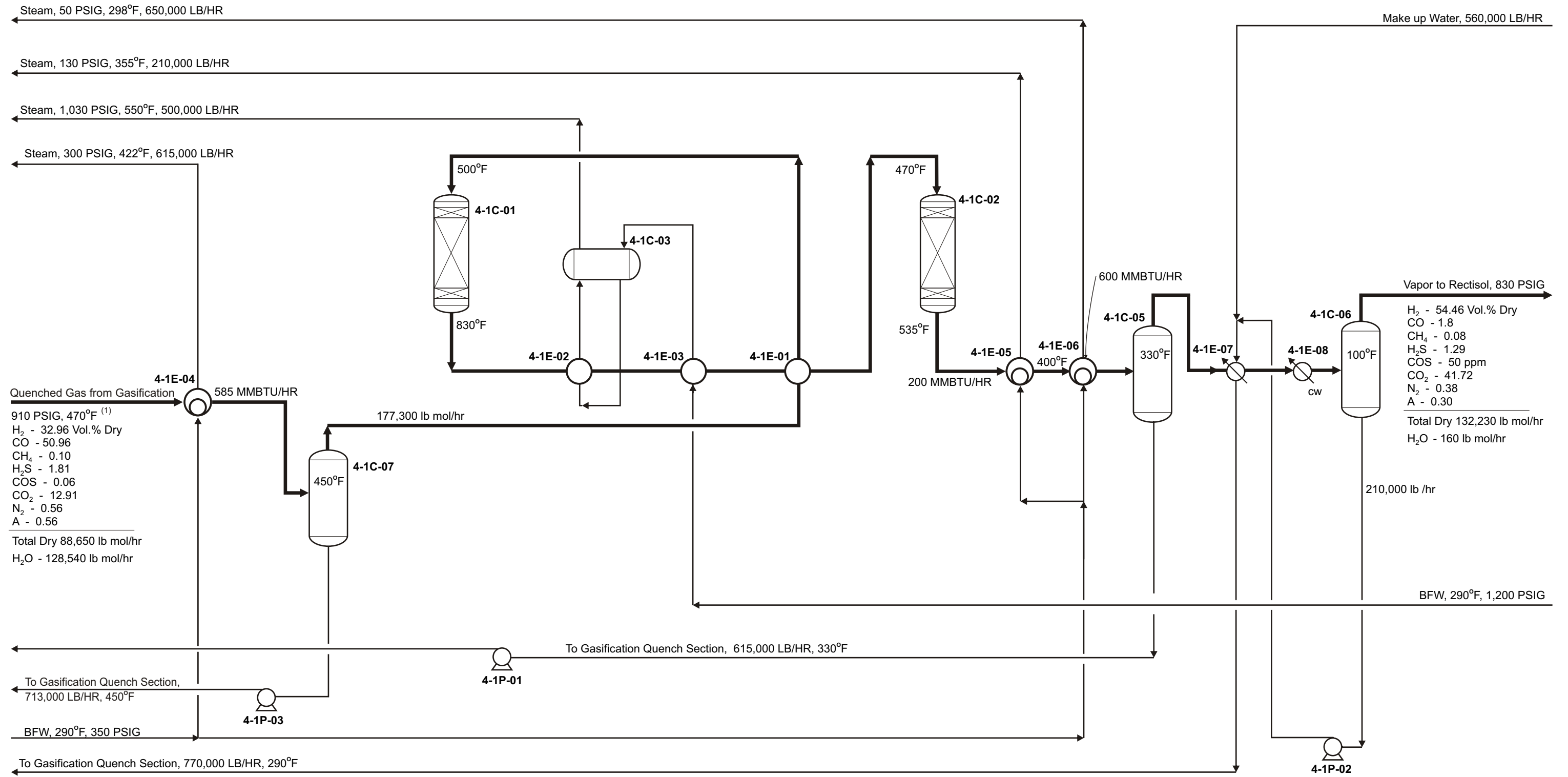

- 4-1C-07  
Hot K.O.  
Drum
- 4-1C-01  
First Stage  
Shift Converter
- 4-1C-03  
1,030 PSIG Steam  
Surge Drum
- 4-1E-01  
First Stage  
Feed Exchanger
- 4-1C-02  
Second Stage  
Shift Converter
- 4-1C-05  
K.O.  
Drum
- 4-1C-06  
Cold K.O.  
Drum
- 4-1E-07  
Make up Water  
Preheat
- 4-1E-02  
1,030 PSIG Steam  
Generator
- 4-1E-03  
BFW  
Preheater

**Note**  
 (1) Total of 3 Trains

**Figure AB-022 Rectisol Process**

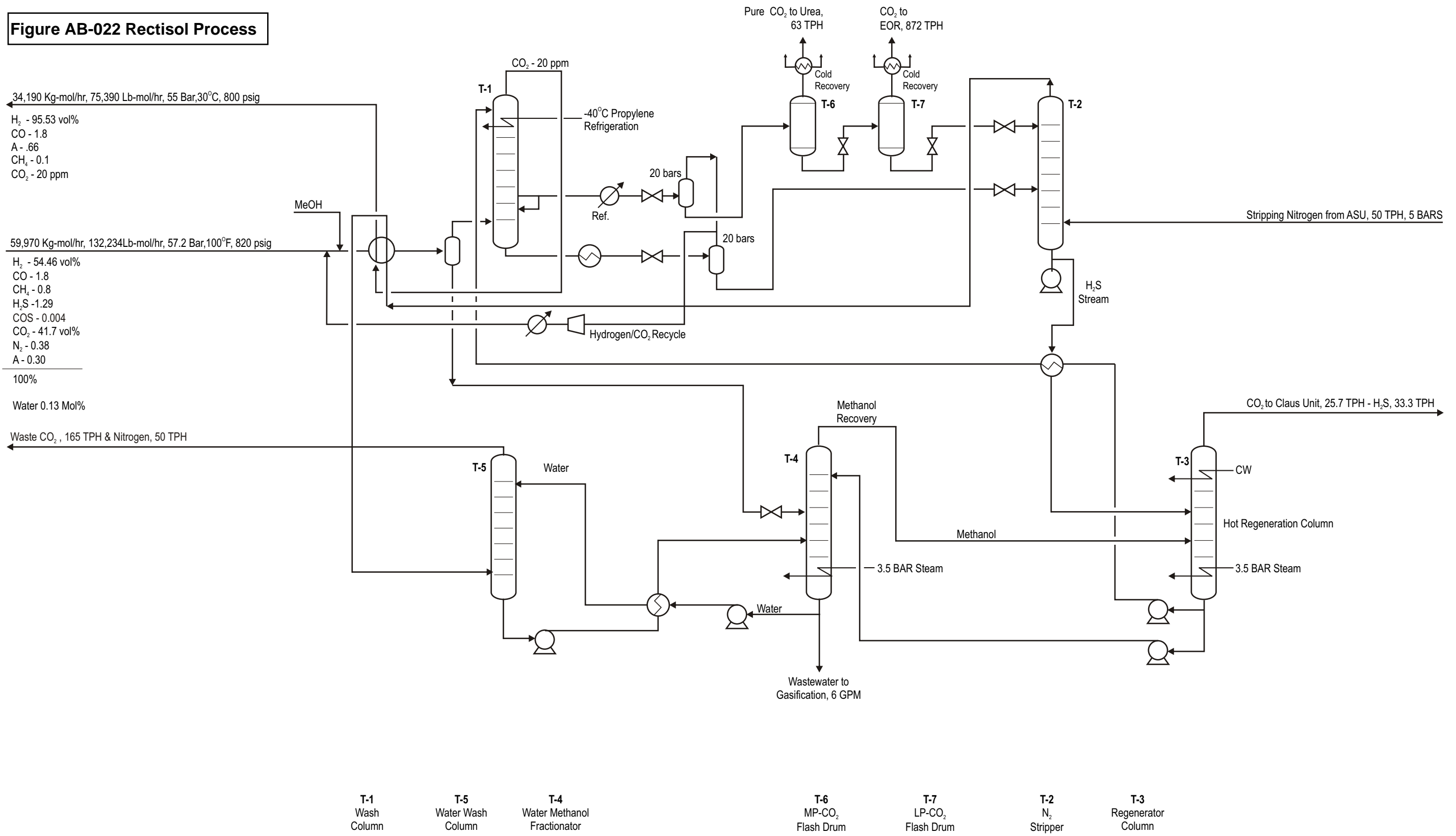

- T-1  
Wash  
Column
- T-5  
Water Wash  
Column
- T-4  
Water Methanol  
Fractionator
- T-6  
MP-CO<sub>2</sub>  
Flash Drum
- T-7  
LP-CO<sub>2</sub>  
Flash Drum
- T-2  
N<sub>2</sub>  
Stripper
- T-3  
Regenerator  
Column

**Figure AB-023 Steam Cracking Ethylene Plant – Cracking Section**

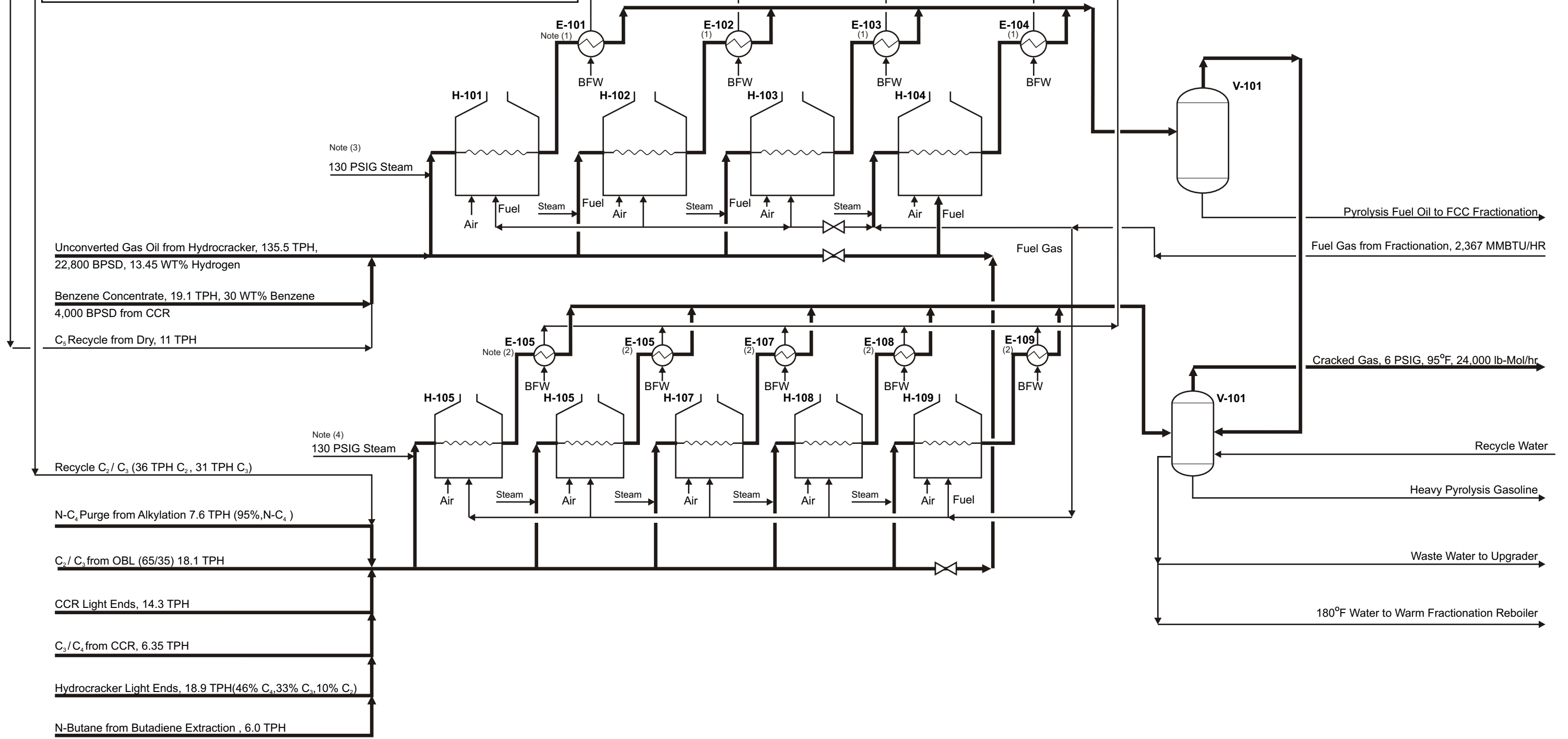

H-101 thru H-103  
Liquid  
Cracking

H-104  
Flexible Feed  
Cracker  
(Gas Liquid)

H-105 thru H-109  
Gas  
Cracking

V-101  
Quench Oil  
System

V-102  
Quench Water  
System

**Notes**

(1)(2) TLE E-101, E-109 Transfer Line Exchanger.

The Steam Superheating is in the Convection Section of the Cracking Heaters. (3) 135 TPH Dilution Steam to Liquid Cracking 0.75 WT% Ratio

(2) TLE E-105, E-109 Including Boiler Feed Water Preheat.

(4) 40 TPH Dilution Steam to Gas Cracking 0.35 WT% Ratio

**Figure AB-024 Steam Cracking Ethylene Plant – Compression/Products Fractionation**

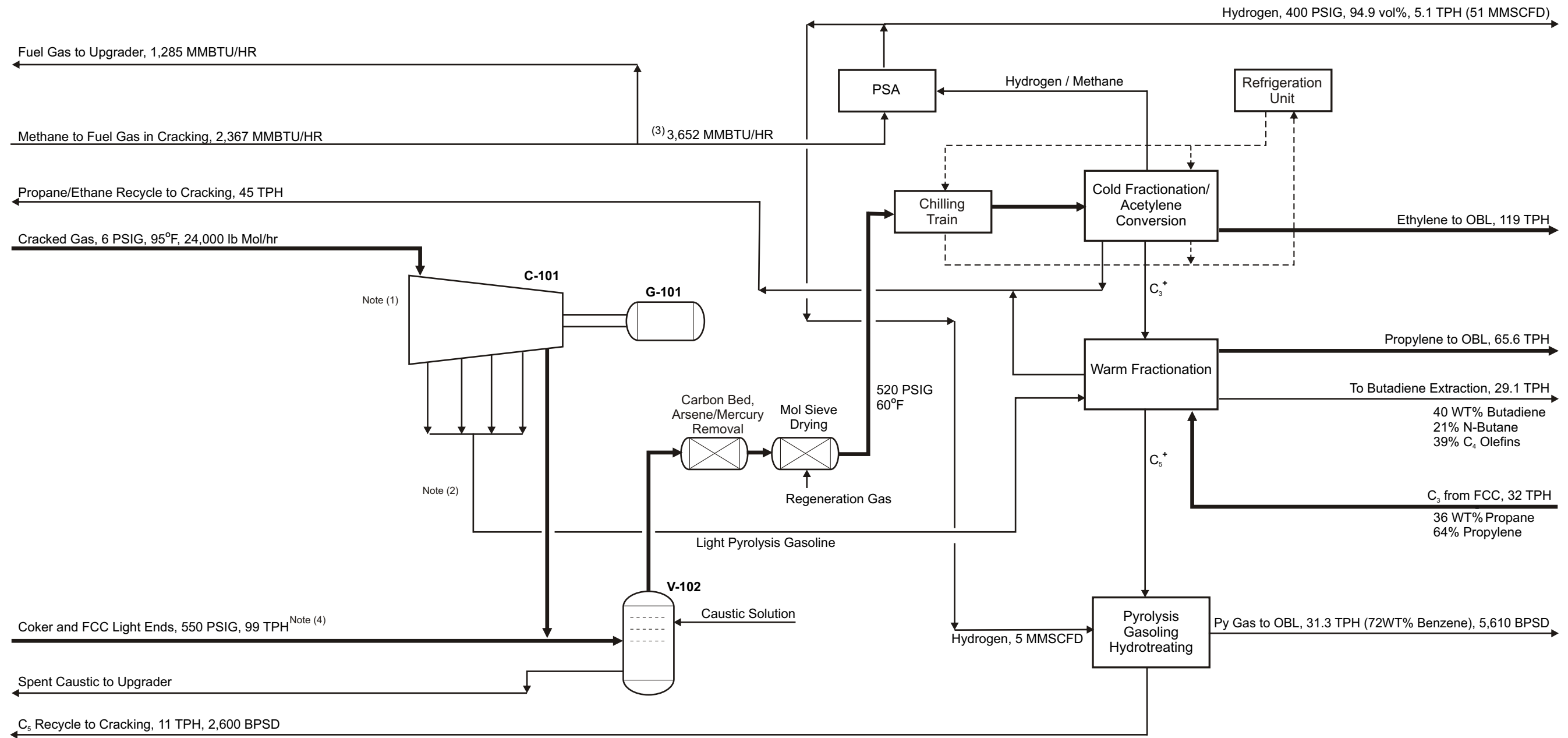

**C-101**  
Cracked Gas  
Compressor

**G-101**  
35,000  
KW Motor

**V-102**  
Caustic  
Scrubber

**Notes**

- (1) Five Stage Compressor with Intercooling, Cooling Water and Condensing C5 / C6
- (2) Condensate of C3- C6
- (3) Mostly Methane, 860 BTU/SCF LHV
- (4) Includes 78 TPH From Coker

January 23, 2006 <b>AB-024</b>	<b>STEAM CRACKING - ETHYLENE PLANT - COMPRESSION / PRODUCTS FRACTIONATION</b>	<b>ALBERTA BITUMEN PROCESSING INTEGRATION STUDY</b>	<b>DAVID NETZER</b> Consulting Chemical Engineer
-----------------------------------	---	---	---

**Figure AB-025 Butadiene Extraction and Recovery**

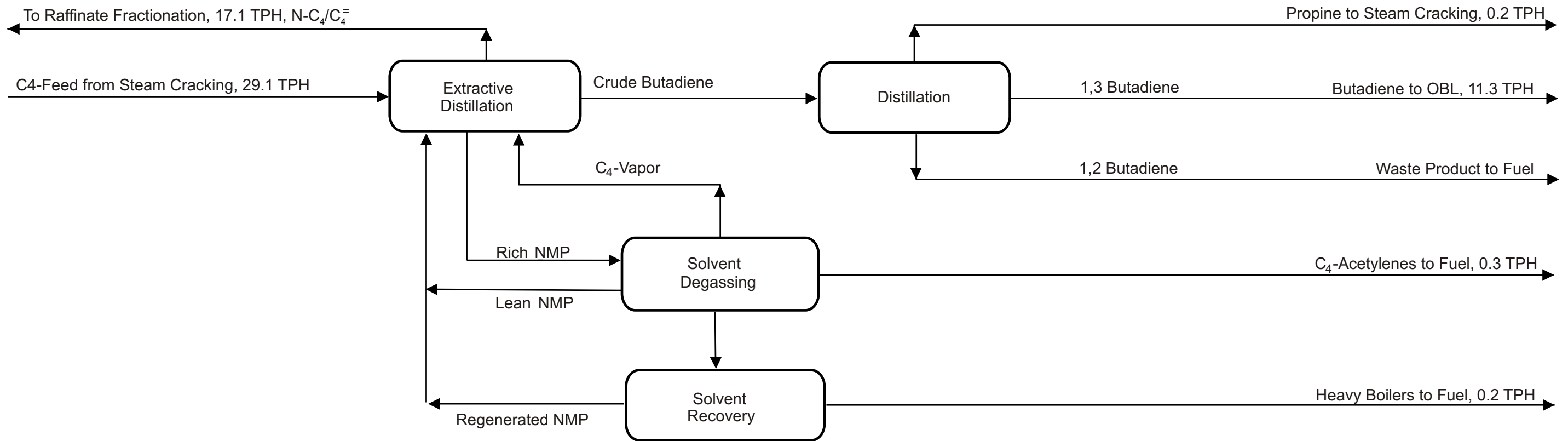
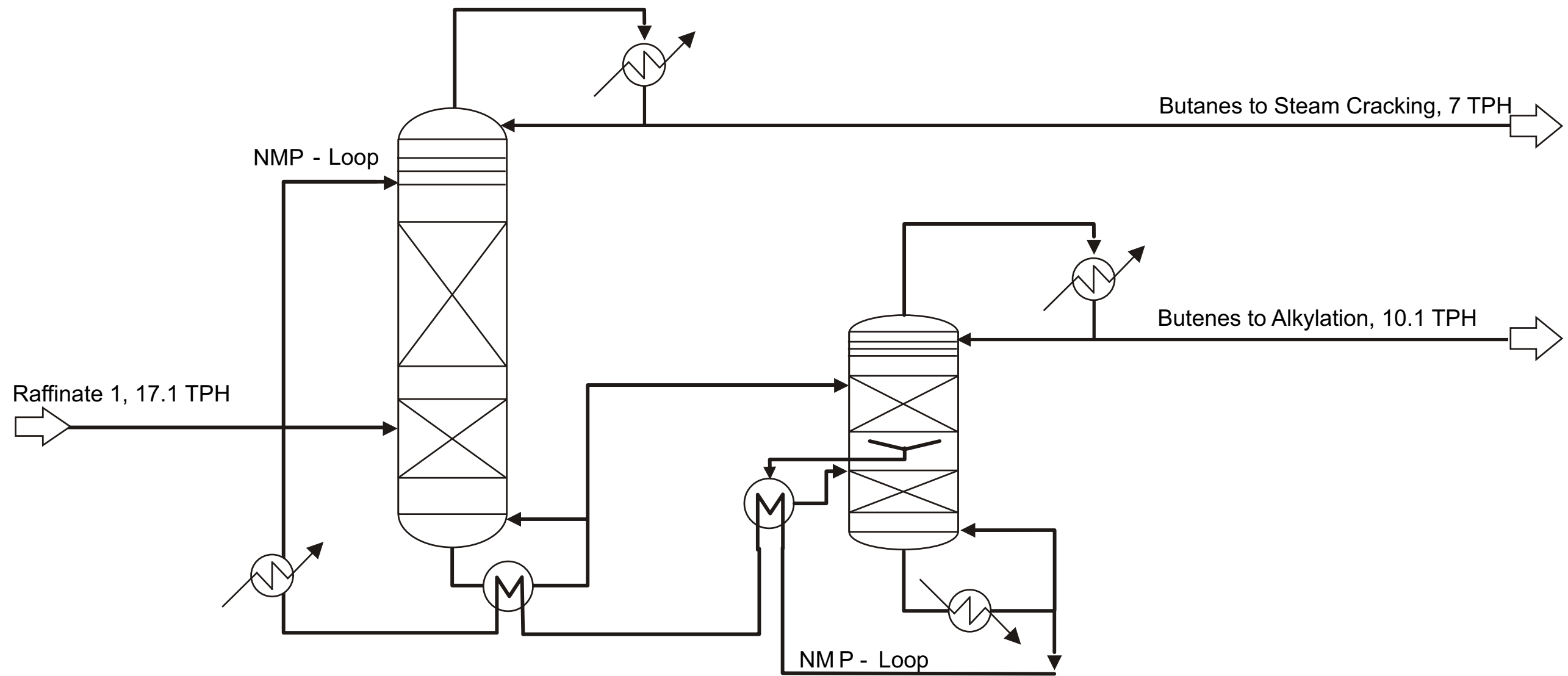
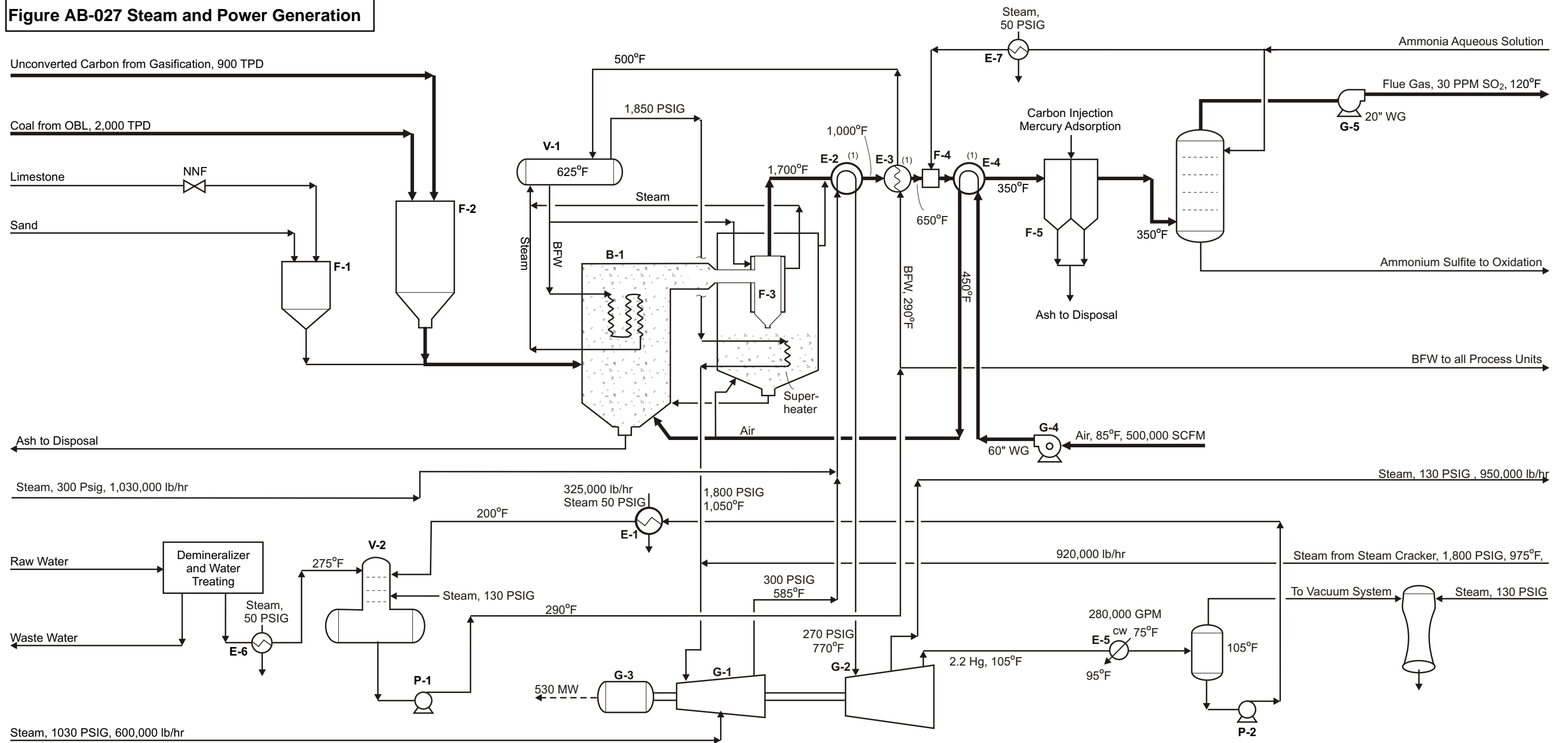



Figure AB-026 C4 Raffinate Separation



**Figure AB-027 Steam and Power Generation**



- E-6  
Preheater
- F-1  
Sand/Limestone  
Silo
- V-2  
Deaerator
- F-2  
Coal/Coke  
Silo
- V-4  
L.P. Cold  
Separator
- P-1  
BFW  
Pump
- E-1  
Condensate  
Preheater
- V-1  
Steam  
Drum
- F-3  
Cyclone  
Steam  
Generator
- B-1  
Circulating  
Fluidized  
Bed  
Boiler
- G-3  
Generator  
540 MW
- G-1  
High  
Pressure  
Turbine  
150 MW
- G-2  
Low Pressure  
Turbine  
390 MW
- E-2  
Re-Superheater
- E-3  
Economizer
- E-7  
Ammonia  
Vaporizer
- G-4  
Combustion  
Air Blower
- F-4  
Denox  
System
- E-4  
Air  
Preheater
- P-2  
Condensate  
Pump
- E-5  
Condenser
- F-5  
Bag  
House
- G-5  
ID Fan

**Note**

(1) These Exchangers are not necessarily Shell and Tubes

January 23, 2006 AB-027	<b>STEAM AND POWER GENERATION</b>	<b>ALBERTA BITUMEN PROCESSING INTEGRATION STUDY</b>	<b>DAVID NETZER</b> <i>Consulting Chemical Engineer</i>
----------------------------	-----------------------------------	---	--

Figure AB-028. TBP of Bitumen

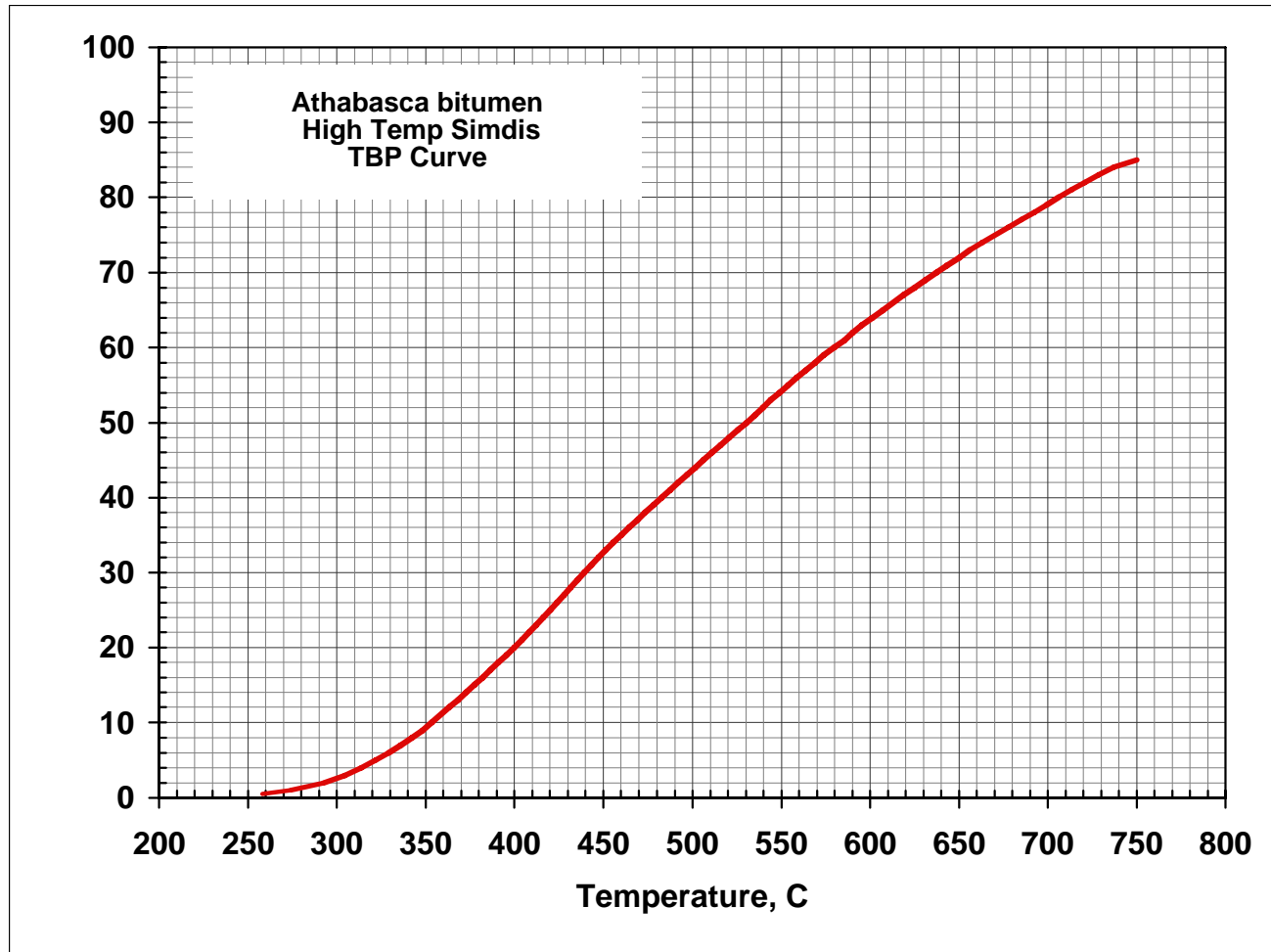

## A.6 Economic Model Price Assumptions

**G L J Petroleum Consultants**  
**Crude Oil and Natural Gas Liquids**  
**Price Forecast**  
**Effective January 1, 2006**  
**www.gljpc.com**

Year	Inflation %	Bank of Canada Average Noon Exchange Rate \$US/\$Cdn	West Texas Intermediate Crude Oil at Cushing Oklahoma		Brent Blend Crude Oil FOB North Sea		Light, Sweet Crude Oil (40 API, 0.3% S) at Edmonton	
			Constant 2006 \$ \$US/bbl	Then Current \$US/bbl	Constant 2006 \$ \$US/bbl	Then Current \$US/bbl	Constant 2006 \$ \$Cdn/bbl	Then Current \$Cdn/bbl
1994	0.2	0.732	21.47	17.18	19.77	15.82	27.77	22.22
1995	2.2	0.729	22.93	18.39	21.25	17.04	30.22	24.23
1996	1.6	0.733	26.84	21.99	24.94	20.43	35.87	29.39
1997	1.6	0.722	24.76	20.61	23.04	19.18	33.46	27.85
1998	0.9	0.675	17.05	14.42	15.17	12.83	24.07	20.36
1999	1.7	0.673	22.61	19.29	20.87	17.81	32.45	27.69
2000	2.7	0.673	34.82	30.22	32.67	28.35	51.35	44.56
2001	2.6	0.646	29.14	25.97	27.34	24.37	44.21	39.40
2002	2.2	0.637	28.52	26.08	27.33	24.99	44.10	40.33
2003	2.8	0.721	33.24	31.07	30.96	28.93	46.71	43.66
2004	1.8	0.768	43.08	41.38	39.76	38.20	55.13	52.96
2005 (e)	2.2	0.825	57.86	56.60	56.38	55.15	70.65	69.11
2006 Q 1	2.0	0.850	56.00	56.00	54.50	54.50	65.25	65.25
2006 Q 2	2.0	0.850	56.00	56.00	54.50	54.50	65.25	65.25
2006 Q 3	2.0	0.850	57.50	57.50	56.00	56.00	67.00	67.00
2006 Q 4	2.0	0.850	58.00	58.00	56.50	56.50	67.50	67.50
2006 Full Year	2.0	0.850	57.00	57.00	55.50	55.50	66.25	66.25
2007	2.0	0.850	54.00	55.00	52.50	53.50	62.75	64.00
2008	2.0	0.850	49.00	51.00	47.50	49.50	57.00	59.25
2009	2.0	0.850	45.25	48.00	43.75	46.50	52.50	55.75
2010	2.0	0.850	43.00	46.50	41.50	45.00	50.00	54.00
2011	2.0	0.850	40.75	45.00	39.50	43.50	47.25	52.25
2012	2.0	0.850	40.00	45.00	38.75	43.50	46.50	52.25
2013	2.0	0.850	40.00	46.00	38.75	44.50	46.25	53.25
2014	2.0	0.850	40.00	46.75	38.50	45.25	46.25	54.25
2015	2.0	0.850	40.00	47.75	38.75	46.25	46.50	55.50
2016	2.0	0.850	40.00	48.75	38.75	47.25	46.25	56.50
2017+	2.0	0.850	40.00	+ 2.0 % /yr	38.75	+ 2.0 % /yr	46.25	+ 2.0 % /yr

GLJ Petroleum Consultants  
**Natural Gas and Sulphur**  
**Price Forecast**  
Effective January 1, 2006

Year	US Gulf Coast Gas		Midwest		Alberta Plant Gate				
	Price @ Henry Hub		Price @ Chicago	AECO-C Spot	Spot		ARP	Aggregator	Alliance
	Constant 2006 \$ \$US/mmbtu	Then Current \$US/mmbtu	Then Current \$US/mmbtu	Then Current \$Cdn/mmbtu	Constant 2006 \$ \$/mmbtu	Then Current \$/mmbtu			
1994	2.42	1.94	2.11	1.98	2.32	1.86	1.81	n/a	n/a
1995	2.12	1.70	1.69	1.15	1.27	1.02	1.31	n/a	n/a
1996	3.08	2.52	2.73	1.39	1.54	1.26	1.63	n/a	n/a
1997	2.97	2.47	2.75	1.84	2.03	1.69	1.96	n/a	n/a
1998	2.55	2.16	2.20	2.03	2.22	1.88	1.94	n/a	n/a
1999	2.72	2.32	2.34	2.92	3.22	2.75	2.48	n/a	n/a
2000	4.99	4.33	4.38	5.08	5.67	4.92	4.50	4.60	n/a
2001	4.54	4.05	4.17	6.21	6.81	6.07	5.41	5.30	5.61
2002	3.67	3.36	3.30	4.04	4.24	3.88	3.88	3.83	3.82
2003	5.88	5.50	5.60	6.66	6.94	6.49	6.13	5.89	6.69
2004	6.44	6.19	6.13	6.88	6.98	6.70	6.31	6.16	6.44
2005 (e)	9.17	8.97	8.24	8.58	8.60	8.42	8.35	8.36	8.45
2006 Q 1	11.00	11.00	10.80	10.45	10.20	10.20	10.20	10.15	11.05
2006 Q 2	10.00	10.00	9.80	10.35	10.10	10.10	10.10	10.00	9.90
2006 Q 3	10.00	10.00	9.80	10.45	10.20	10.20	10.20	10.10	9.90
2006 Q 4	11.00	11.00	10.85	11.05	10.80	10.80	10.80	10.75	11.10
2006 Full Year	10.50	10.50	10.30	10.60	10.35	10.35	10.35	10.25	10.50
2007	8.60	8.75	8.90	9.25	8.80	9.00	9.00	9.00	8.90
2008	7.20	7.50	7.65	8.00	7.45	7.75	7.75	7.75	7.45
2009	6.60	7.00	7.15	7.50	6.85	7.25	7.25	7.25	6.90
2010	6.25	6.75	6.90	7.20	6.40	6.95	6.95	6.95	6.65
2011	5.90	6.50	6.65	6.90	6.05	6.65	6.65	6.65	6.35
2012	5.75	6.50	6.65	6.90	5.90	6.65	6.65	6.65	6.35
2013	5.75	6.65	6.80	7.05	5.95	6.80	6.80	6.80	6.50
2014	5.75	6.75	6.90	7.20	5.95	6.95	6.95	6.95	6.65
2015	5.75	6.90	7.05	7.40	6.00	7.15	7.15	7.15	6.80
2016	5.75	7.05	7.20	7.55	6.00	7.30	7.30	7.30	6.95
2017+	5.75	+2.0% /yr	+2.0% /yr	+2.0% /yr	6.00	+2.0% /yr			

Unless otherwise stated, the gas price reference point is the receipt point on the applicable provincial gas transmission system gate, known as the plant gate.

The plant gate price represents the price before raw gas gathering and processing charges are deducted.

AECO-C Spot refers to the one month price averaged for the year.

## A.7 Colt Engineering Due Diligence Report

### Review of the Alberta Bitumen Processing Integration Study

For:

### Alberta Economic Development Alberta Department of Energy Hydrocarbon Upgrading Task Force Steering Committee

<b>Rev.</b>	<b>Date</b>	<b>By</b>	<b>Description</b>	<b>Colt Approved</b>	<b>Client Approved</b>
A	March 28, 2006	F. Nolte	Issued for Approval		

*PREPARED BY  
COLT ENGINEERING CORPORATION  
EDMONTON, ALBERTA*

This document represents work done by Colt Engineering Corporation (Colt) performed to recognize engineering principles and practices. The work is based upon the project scope and design information as described herein and as provided by the Owner. Any representations in this document are furnished for general information only and are not in any way guaranteed or warranted by Colt or its sub-consultants or on behalf of the Owner or their respective employees. None of the above named parties or individuals shall be liable, in negligence or otherwise, for any reliance which may be placed by any other party upon any representations contained herein.

## TABLE OF CONTENTS

1.	Introduction.....	1
2.	Unit Operations and Technologies .....	1
2.1	Upgrader .....	2
2.2	Steam Cracker.....	2
2.3	Hydrogen Syngas Plant (by Gasification) .....	3
2.4	Steam Power Generation .....	4
2.5	Air Separation Plant.....	5
4	Conversion Unit Yields .....	6
3.1	Upgrader .....	6
3.1.1	Coker.....	6
3.1.2	Hydrocracker/CFHTU/FCC/Alkylation .....	6
3.1.3	NHT/CCR/Diesel Hydrotreater .....	7
3.1.4	Sulphur Units .....	7
3.2	Petrochemical Yields .....	8
4	Capital Cost Estimate.....	8
4.1	Process Use to Build this Cost Estimate.....	8
4.2	Quality of the Cost Estimate.....	8
4.3	Assessment of Project Cost Risk and Contingency .....	9
4.4	Cost Estimate Classification .....	10
5	Geographic Location Factor .....	12
6	Reality of the Synergies and Resulting Cost Savings.....	13

## **INTRODUCTION**

Colt Engineering was retained by Alberta Economic Development, Alberta Energy, and the Steering Committee to provide advice and due diligence for the Bitumen Processing Integration Study. Specifically the Steering Committee requested that Colt provide their advice and commentary on the following points:

- Are the proposed suite of unit operations and technologies proven?
- Comment on the reasonableness of the yields assumed, for conversion processes, based upon Colt's experience.
- Is the estimated Total Installed Cost (TIC) of the facility and that of each individual of each unit reasonable.
- Review the assumptions used to generate the Geographic Location factor with respect to the basis Gulf Coast construction cost.
- Is the operation of the integrated processes feasible and reasonable in accordance with normal world scale plant standards for service factor, redundancy and flexibility? In general is this a reliable scheme.
- Are the synergies and resulting cost savings as identified in the study realistic?

It is on this basis that all of the comments in this review will be centered.

A review of the economic model, feedstock and product pricing models was not a part of the scope of this review.

### **2. Unit Operations And Technologies**

This study is premised on achieving the maximum uplift in the value for the products (most beneficial use), made from a bitumen feed, can be achieved in an integrated facility that produces hydrocarbon fuels products, petrochemical products and fertilizer products. All of the products are commodities traded on a world scale. Almost all of the products are currently produced in Alberta; often from less advantageous feed stocks (natural gas and natural gas liquids).

A second and closely related concept is that the low hydrogen to carbon ratio and impurities (e.g. sulphur) in the bitumen feed naturally directs some of the bitumen conversion towards the production of higher value and low H to C products (e.g. light olefins and benzene). A third focus of the study was the appropriate selection of technologies and novel modification of existing technologies can reduce the capital cost of the overall facility.

It is important to note that all of the process technologies are well proven in industrial practice today and there are multiple licensors of each kind of technology. All of the proposed unit operations (with the exception of coke gasification) are currently in operation with similar feedstock in Western Canada. Further, many of the technologies have evolved to



the point that open art (i.e. non- licensed) technologies could be used in many of the units. Not having to license some technologies will further reduce capital and ongoing operating costs.

This configuration is only one of many possible configurations for upgrading bitumen. It does represent a plausible base case scenario to compare other possible solutions.

An in depth appraisal of the individual technologies selected by the consultant for each unit in the facility is beyond the scope of this review, but comments regarding some of the key technologies will be provided.

## **2.1 Upgrader**

The upgrader units selected are characteristic in size and configuration to those used a number of the Alberta Oil Sands upgraders and refineries processing bitumen derived synthetic oils. The atmospheric crude, vacuum and delayed coker combination for fractionation of distillates and gas oils and the conversion of residue is well proven in Alberta upgraders. The size of individual trains is in line with the throughput of existing facilities elsewhere. Major equipment is of a size that can be manufactured locally and transported to site. Larger sized vessels could be assembled onsite. For example the largest diameter coke drums that can currently be manufactured in Edmonton and transported to site would be 32 ft diameter.

The relatively high total acid number for tar sand bitumen does require that appropriate metallurgy is required in the front-end unit of the upgrader. The simplified atmospheric crude and vacuum flowsheets reduces the number of pieces of equipment and piping that requires this specialized metallurgy and this reduces the cost of these units significantly.

Several existing Alberta refineries crack tar sands derived gas oils using hydrocracking and fluid cat cracking (FCC). Pretreating of FCC feed to levels that yield a gasoline product that meets the existing sulphur specifications has now proven in an Edmonton refinery. The proposed alkylation technology is similar to that used at Alberta EnviroFuels (AEF) in Edmonton and does represent a feasible direction for alkylation technology. Continuous Catalytic Reforming (CCR) of oil sands derived naphtha meeting gasoline octane spec has been in operation for 20 years.

The environmental units of H<sub>2</sub>S absorption/regeneration, sour water stripping and sulphur conversion are all also well proven technologies. Numerous plants of this scale are currently operating in Alberta. The Sulphur plant tail gas cleanup unit is a novel application of technology used elsewhere as is the disposal of process effluent water in the gasifier.

## **2.2 Steam Cracker**

The feeds to the ethylene plant are somewhat unusual in that various low value streams from the bitumen refinery are used directly in the ethylene plant as feedstock. These feeds are not ideal in that they require more capital than would be required using a pure ethane feed. However, by using these streams as feed to the ethylene plant, the capital requirements to

deal with these streams in the refinery are avoided resulting in a synergistic reduction in overall capital for the integrated facility.

There are several examples of companies using this approach. Most notably are Exxon and Shell.

The heat integration used in this preliminary design is not typical but should result in lower capital and higher reliability than what is normally done in the industry. The proposed design uses electric motor drives for all of the large compressors. The typical ethylene plant will use steam turbine drives. There is one plant designed by SWEC located near New Orleans that currently uses a large electric motor on the propylene compressor.

There are several technical issues that require further study as the project progresses into the next phases. However, these issues such as the location of the acetylene hydrogenation reactors in the process, do not impact the overall feasibility of the concept.

### **2.3 Hydrogen Syngas Plant (By Gasification)**

One of the key economic pieces of this integrated facility is based around the gasification of petroleum coke to produce hydrogen needed by the upgrader. The facility is highly dependent upon reliable operation of this unit. The non-reliance on natural gas as a feedstock to the hydrogen production significantly reduces feedstock cost. The upsurge in gasification of petroleum residues in the 1990's has resulted in significant numbers of new units, improvements in this technology and a corresponding increase in operating reliability.

Higman and Burgt have published a fairly recent (2003) and thorough review of gasification technologies. This publication cautions that the gasification of Athabasca coke, with its high levels of Vanadium and Nickel, exceed current long-term experience for fresh feed in gasifier operation. Recycle configurations should be avoided so as to avert metals build up in the carbon management system. Depending upon the source of the bitumen (mined vs. SAGD) the ultra-fine aluminosilicates from clays could deposit in the gasifier and syngas coolers.

The process concept calls for unconverted coke (and associated metals and ash) to be rejected from the gasifier and used as feed to the fluidized bed boilers. This effectively removes the requirement for unconverted coke recycle in the gasifier and reduces any issue with metals and other such solids in the gasifier.

The shift gas and Rectisol processes used to further convert and then treat the offgas gas from gasification is mature technology. Rectisol is a fairly expensive technology given the refrigeration requirements, but has the feature of selectivity toward COS and the ability to easily meet the required ammonia synthesis catalyst sulphur limit. These two factors govern in technology selection here.

## 2.4 Steam Power Generation

A third party consultant reviewed the steam power generation portions of the subject study. This consultant has considerable experience in fluidized boiler technology. This review includes the technology selection and the suitability of potential fuel feedstocks that include:

- Unconverted carbon from gasification
- Coal
- Petroleum coke from bitumen delayed coking

The combined mixture of unconverted carbon from the gasification process, coal, and petroleum coke from bitumen delayed coking has been assessed and it is suggested that the following be adopted in the study.

- 1) While some commercial experience exist combusting petroleum coke within CFB boilers, a strategy of blending petroleum coke with a lower BTU coal with significant ash content is considered to be a low risk blend of fuels.
- 2) The addition of unconverted carbon to this fuel mix might lead to some carbon loss to the downstream bag house, which would significantly lessen the need for carbon injection prior to the bag house to remove mercury.

The method adopted for flue gas treatment indicates installing an SCR (with ammonia aqueous solution injection) upstream of the air heater for secondary NOX removal and an ammonia scrubber installed downstream of the bag house. While the arrangement would work technically, further study is suggested to determine if the local (Edmonton) NOX and slip stream ammonia emission objectives can be more economically achieved within the CFB boiler using a simplified but well established process of injecting aqueous ammonia at the cyclone inlet which is a well established lower capital cost option.

The ammonia scrubber concept when installed downstream of a bag house offers considerable opportunity to generate a very high value by product. The final evaluation of using ammonia scrubbing versus a more traditional limestone injection system will be very dependent on the applicable market prices. Many other sites have considered ammonia scrubbing for the same by product market opportunities reasons. This combination offers the opportunity that if both systems are installed (or provided for) to produce either a high value fertilizer from the ammonia-based feedstock or to shift towards a lower input cost feedstock such as limestone if market conditions change.

The current state of the art for CFB boilers varies considerably from the smaller sizes that frequently provide very high levels of availability through to the state of the art designs that have reached capacities of 250 to 300 MWe rated capacity. Given the project's stated need to achieve a very high level of availability and given the base load nature of the project concept, an alternate to the three unitized systems (with one as spare) is suggested.

This would include installing a total of five CFB boilers (versus MWe), which are a well established proved design. This very reliable arrangement could then be integrated into an

integrated power island based upon the concept of selecting the matching steam turbine plant based upon the multiple process steam injections, extractions, the need for reliability, and the grid requirement to minimize the overall exposure to back-up power requirements (for the facility) while maximizing the market opportunities.

If the CFB boilers were selected appropriately with the 20% redundancy suggested above, a reliability approaching 99% could be expected. Further evaluation of the steam power cycle and combinations of multiple high pressure topping turbines and low pressure back pressure turbines would provide a an optimum match between capital savings with larger turbine units versus the flexibility provided with multiple shaft combinations.

In addition, a very high level review of the power generation and steam cycle was made which suggest that the overall optimization process would benefit from the involvement of a senior power engineer based upon:

1. The CFB heat balance indicated suggests a final feedwater temperature to the waterwalls of 550 F, which is high for an 1800 psig boiler.
2. The CFB indicated provides only for evaporation duty in the furnace and cyclone areas except for the superheater that is installed in the FBHE whereas all of the reheat service is provided in the convection pass. As the fuel mix changes, this will lead to excess spraying of the superheater and potentially a shortfall within the reheater. It is more typical to split this duty more equally between the two areas to provide some range of fuel flexibility.
3. The reheater steam pressure appears to be constrained by the non-power island components. Another iteration is required to determine if a higher reheat pressure is feasible.
4. The condenser is equipped with a steam jet air extraction system that seems unusual for a high availability system. Typically similar power cycles would utilize a liquid ring vacuum pump that has a higher overall contribution to efficiency.
5. The reference to waste soil combustion should be examined to determine the applicability to this application.
6. Additional stages of feedwater heating may prove cost effective in this cycle once the drum-saturated conditions are corrected.
7. The fireside exposure of the CFB convective pressure parts to the high sulphur oxide environment is relatively unusual and may warrant some injection of limestone in the CFB to lessen the SO<sub>3</sub> in the rear pass of the boiler. The stack temperature of 350 F appears significantly conservative to avoid most problems.

## **2.5 Air Separation Plant**

These units are generic, and numerous licensors exist. A number of such units exist in the Edmonton area.

### **3.0 Conversion Unit Yields**

Technologies for the conversion of bitumen derived materials into intermediate and saleable products are readily available from numerous licensors. Variations between the yields from these units can be significant. The consultant has obtained his yield information from a variety of sources; public domain, private industry and from his industrial experience.

It was noted that the composition of the bitumen that was used in the basis (Appendix 4) differs from other Athabasca bitumen analyses found in literature. The H/C atomic ration in the bitumen feed used in this work is 1.41. Historical information obtained from various sources indicates this could be 1.50. The impact of this difference would be to reduce the amount of hydrogen addition required to bring the final products to an appropriate level. This could result in the actual units being smaller and less expensive or the amount of H<sub>2</sub> available for export could be higher.

### **3.1 Upgrader**

#### **3.1.1 Coker**

Conversion of vacuum residue is estimated to reject 33% of the carbon to coke and produce 58 wt% liquid products from the feed. These yields were supplied to the consultant by a technology licensor with experience in tar sands coking. Several references have indicated this coke yield may be higher and some references have indicated that coke yields as high as 40% are possible from this type of feed. Production of additional coke from the Delayed Coker would drive down the liquid yield from this unit by up to 7%, and a corresponding offset in the amount of import coke into the facility. One other outcome of a higher coke yield is an increase in the hydrogen content of the coker products. This would lower hydrogen consumption in the upgrader/refinery.

#### **3.1.2 Hydrocracker/CFHTU/FCC/Alkylation**

The ability to hydrocrack and catalytically crack tar sands derived liquids has been demonstrated for over 20 years in Alberta. These technologies are in a mature state of development and recent (<10 year) catalyst developments have greatly improved conversion, aromatics saturation and cetane of highly aromatic stocks; such as those from tar sand bitumen.

Hydrocracker yields of 70% 650- product are well within the capabilities of catalysts operating at the stated hydrogen partial pressures. The lower than normal end hydrocracker feed will help reduce the metals loading and deactivation of catalyst and should allow reasonable run lengths for each hydrocracker catalyst charge.

FCC yields based on hydrotreated feed to the cat cracker are in line with industry experience. There is considerable latitude in adjusting these conversions should there be a desire to optimize the petrochemical feed off this unit. Cat feed hydrotreating (CFHTU) is proven as a means to achieve a cat gasoline that meets the low sulphur gasoline requirements. Reduction in coke and slurry precursors in the CFHTU product moves the conversion in the FCC to higher olefin and dry gas yields in order to heat balance the FCC.

The solid base alkylation unit is relatively new technology, but the yields stated are similar to those from liquid acid base technology and therefore technology selection for this unit will not materially effect the alky unit production rates and yields.

### 3.1.3 NHT/CCR/Diesel Hydrotreater

The requirement to desulphurize CCR feed and achieve ULSD specification on refinery diesel products is well understood.

CCR technology is mature and currently at least one unit has long-term history (20 years) in tar sands derived naphtha service. Relative high levels of octane improvement have been achieved in these units.

Numerous ULSD units are starting up in the spring of 2006 and their operation will be well known in time for detailed design on this unit. The maximum cetane index uplift for units of this type are in the range of 4-7 cetane index and are dependent largely on the degree of aromatics saturation (i.e. hydrogen partial pressure). The consultant has indicated significant prior personal experience in diesel Hydrotreating with aromatics saturation. Future pilot studies will have to determine the appropriate cetane uplift, aromatics saturation and working pressure for this unit.

### 3.1.4 Sulphur Units

The feed to the amine, sulphur and sour water units are not expected to very different from any existing upgraders/refineries operating on Athabasca bitumen. The sulphur conversion efficiency listed in this study is well with the reach of current technology and the tail gas clean-up technology proposed will keep sulphur emissions below the requirements for sulphur units of this size.

<b>3. Alberta Sulphur Recovery Guidelines (Interim Directive ID 2001-03)</b>		
<b>% of sulphur inlet that must be recovered</b>		
<b>Sulphur inlet rate (tonnes/day)</b>	<b>Design sulphur recovery criteria</b>	<b>Calendar quarter-year sulphur recovery guidelines</b>
1-5	70	69.7
>5-10	90	89.7
>10-50	96.2	95.9
>50-2000	98.5 - 98.8 <sup>1</sup>	98.2 – 98.5 <sup>2</sup>
>2000	99.8	99.5

<sup>1</sup> Recovery = 98.18185 + 0.187259 log<sub>10</sub> (sulphur inlet rate).

<sup>2</sup> Calendar quarter-year recovery = 97.88185 + 0.187259 log<sub>10</sub> (sulphur inlet rate).

Disposal of stripped sour water, sulphur and ammonia is considered in this work.

### **3.2 Petrochemical Yields**

The yields that are used in the study are based on a combination of licensor preliminary information and industry experience in units of this type and appear to be reasonable. Linde AG, of Munich Germany has confirmed the yields as stated in the report. Linde has a well deserved reputation of designing and building pacesetter ethylene plants based on the feed stocks that are very similar to the feeds that are used in this study the cracking of hydrocracker residue into olefins has been employed elsewhere with similar product yields.

### **4.0 Capital Cost Estimate**

Colt's review of the capital cost estimate prepared by the consultant focused on process used for arriving at the total cost (including equipment, materials, labor, indirect construction costs, engineering, and contingencies), the sources of cost information and the factors that were used to adjust benchmark numbers from their original basis and source to a constructed in Alberta total. At the outset it is important to note that the basis for the cost numbers in the consultant's estimate are *instantaneous overnight construction costs on a US Gulf Coast Basis*. This is a reference basis that nominally the net present cost of a plant and does not consider the time value of money spread across the project duration, financing costs, cost escalation, owner costs etc. The project economic model considers these real world considerations in assessing the ROI.

#### **4.1 Process Use to Build this Cost Estimate**

The consultant followed a traditional approach to developing a conceptual level capital cost estimate for the purposes of this study. The methods used are typical for this phase of project development and for this degree of engineering effort and definition.

Review of individual process unit (ISBL) costs was premised on verification of data source. Wherever any costs were listed; were they were supplied from a source that would have a working knowledge of the purpose, scope of that technology and recent construction cost for such a unit? The consultant has confirmed the information was provided by process/technology licensors with current knowledge of the installed cost of recently constructed facilities. In most cases the consultant approached multiple sources and checked to ensure consistency in the cost numbers.

Offsites and Utility (OSBL) cost were estimated on the basis of a factor of ISBL. These factors are very general in nature and often do not reflect some project specific requirements. The consultant has attempted to mitigate the cost risk on his OSBL facilities by preparing some quantity estimates for major items such as the tank farm and powerhouse. These were compared to factors generally applied in the conceptual engineering phase of a project to verify that the factors were within a reasonable range. The OSBL factor used was about 1.5 times the cost of the ISBL units.

#### **4.2 Quality Of The Cost Estimate**

The Association for the Advancement of Cost Engineering has developed recommended practices for the classification of cost estimates for the process industries. A discussion of the

Cost Estimate Classification system is listed at the end of this section. Generally the quality and therefore accuracy of the estimate is in direct relation to the degree of scope development.

The internal classification of the cost estimates used by the major oil companies and the major petrochemical companies closely follow the general guidelines and definitions that the AACE have developed.

The cost estimate for the Alberta Bitumen Process Integration Study exceeds the requirements for a Class 5 Cost Estimate and falls short of the requirements for a Class 4 Cost Estimate as defined by AACE recommended Practice No. 18R-97. The cost estimate is based largely upon capacity factored and analogy with other units of similar capacity that have been constructed within the last several years, but constructed largely elsewhere in the world.

Using the AACE recommended Practice as a guideline, the accuracy of the cost estimate as presented in the Integration study is in the order of -30% to +50% assuming that the appropriate contingency range has been determined.

### **4.3 Assessment Of Project Cost Risk And Contingency**

The formal definition of contingency is:

*An assessment, made by a team of professionals, of the amount of funds which, when added to the line item estimate will reflect an equal chance of under run or over run given the relative stability of the scope and assumptions upon which the estimate is based.*

Major oil companies and major petrochemical companies have well defined guidelines and procedures for determining the appropriate contingency based on the class of the cost estimate. The determination of the appropriate contingency is usually tied very closely to a Commercial Risk Assessment, which is part of the Project Delivery System that would be normally followed by the particular company.

For a Class 4 or equivalent estimate, the typical contingency range is 20 to 35%. The exact range depends on the degree of risk that is determined. A range as high as 40% would indicate that the company would consider the project to have a very high commercial risk.

It is our opinion that a total contingency of 40% is justified for this stage of project development and in particular for the feasibility economics that are a part of this study. The consultant has indicated his assertion that the costs listed in his cost estimate already reflect a certain degree of contingency and that it was in the range of 20%. It was our opinion that some incremental amount to cover the additional cost risk concerns should be applied. The consultant has suggested 17.5% be added to his numbers to bring the total contingency to 40% and it is our opinion that this magnitude of addition risk contingency is justified. Obviously the final contingency that is applied to any project should be the decision of the investor in their review of this work.



#### 4.4 Cost Estimate Classification

The Association for the Advancement of Cost Engineering (AACE) ([www.aacei.org](http://www.aacei.org)) developed the following Recommended Practices.

<http://oecm.energy.gov/Portals/2/g4301-1x.pdf>

Recommended Practices:

- No. 17R-97, Cost Estimate Classification System
- No. 18R-97, Cost Estimate Classification System – As Applied in Engineering, Procurement and Construction for the Process Industries

The purpose of these recommended practices is to provide guidance for classifying project cost estimates. Figure 1 is a summary of the Cost Estimate Classification System for the Process Industries.

Figure 1. – Cost Estimate Classification Matrix for Process Industries

ESTIMATE CLASS	Primary Characteristic	Secondary Characteristic			
	LEVEL OF PROJECT DEFINITION Expressed as % of complete definition	END USAGE Typical purpose of estimate	METHODOLOGY Typical estimating method	EXPECTED ACCURACY RANGE Typical variation in low and high ranges [a]	PREPARATION EFFORT Typical degree of effort relative to least cost index of 1 [b]
Class 5	0% to 2%	Concept Screening	Capacity Factored, Parametric Models, Judgment, or Analogy	L: -20% to -50% H: +30% to +100%	1
Class 4	1% to 15%	Study or Feasibility	Equipment Factored or Parametric Models	L: -15% to -30% H: +20% to +50%	2 to 4
Class 3	10% to 40%	Budget, Authorization, or Control	Semi-Detailed Unit Costs with Assembly Level Line Items	L: -10% to -20% H: +10% to +30%	3 to 10
Class 2	30% to 70%	Control or Bid/ Tender	Detailed Unit Cost with Forced Detailed Take-Off	L: -5% to -15% H: +5% to +20%	4 to 20
Class 1	50% to 100%	Check Estimate or Bid/Tender	Detailed Unit Cost with Detailed Take-Off	L: -3% to -10% H: +3% to +15%	5 to 100

Notes:

[a] The state of process technology and availability of applicable reference cost data affect the range markedly. The +/- value represents typical percentage variation of actual costs from the cost estimate after application of contingency (typically at a 50% level of confidence) for given scope.

[b] If the range index value of "1" represents 0.005% of project costs, then an index value of 100 represents 0.5%. Estimate preparation effort is highly dependent upon the size of the project and the quality of estimating data and tools.

Class 5 Estimate	
ANSI Standard Reference Z94.2-1989 Name:	Order of magnitude estimate (typically -30% to +50%).
Alternate Estimate Names, Terms, Expressions, Synonyms:	Ratio, ballpark, blue sky, seat-of-pants, ROM, idea study, prospect estimate, concession license estimate, guesstimate, rule-of-thumb.
Description:	Class 5 estimates are generally prepared based on very limited information, and subsequently have wide accuracy ranges. As such, some companies and organizations have elected to determine that due to the inherent inaccuracies,

	such estimates cannot be classified in a conventional and systemic manner. Class 5 estimates, due to the requirements of end use, may be prepared within a very limited amount of time and with little effort expended, sometimes requiring less than an hour to prepare. Often, little more than proposed plant type, location, and capacity are known at the time of estimate preparation.
Level of Project Definition Required:	0% to 2% of full project definition.
End Usage:	Class 5 estimates are prepared for any number of strategic business planning purposes, such as but not limited to market studies, assessment of initial viability, evaluation of alternate schemes, project screening, project location studies, evaluation of resource needs and budgeting, long-range capital planning, etc.
Estimating Methods Used:	Class 5 estimates virtually always use stochastic estimating methods such as cost/capacity curves and factors, scale of operations factors, Lang factors, Hand factors, Chilton factors, Peters-Timmerhaus factors, Guthrie factors, and other parametric and modeling techniques.
Expected Accuracy Range:	Typical accuracy ranges for Class 5 estimates are - 20% to - 50% on the low side, and +30% to +100% on the high side, depending on the technological complexity of the project, appropriate reference information, and the inclusion of an appropriate contingency determination. Ranges could exceed those shown in unusual circumstances.
Effort to Prepare (for US\$20MMproject):	As little as 1 hour or less to perhaps more than 200 hours, depending on the project and the estimating methodology used.

Class 4 Estimate	
ANSI Standard Reference Z94.2-1989 Name:	Budget estimate (typically -15% to + 30%).
Alternate Estimate Names, Terms, Expressions, Synonyms:	Screening, top-down, feasibility, authorization, factored, pre-design, pre-study.
Description:	Class 4 estimates are generally prepared based on limited information and subsequently have fairly wide accuracy ranges. They are typically used for project screening, determination of feasibility, concept evaluation, and preliminary budget approval. Typically, engineering is from 1% to 5% complete, and would comprise at a minimum the following: plant capacity, block schematics, indicated layout, process flow diagrams (PFDs) for main process systems, and preliminary engineered process and utility equipment lists.
Level of Project Definition Required:	1% to 15% of full project definition.
End Usage:	Class 4 estimates are prepared for a number of purposes, such as but not limited to, detailed strategic planning, business development, project screening at more developed stages, alternative scheme analysis, confirmation of economic and/or technical feasibility, and preliminary budget approval or approval to proceed to next stage.
Estimating Methods Used:	Class 4 estimates virtually always use stochastic estimating methods such as equipment factors, Lang factors, Hand factors, Chilton factors, Peters-Timmerhaus factors, Guthrie factors, the Miller method, gross unit costs/ratios, and other parametric and modeling techniques.
Expected Accuracy Range:	Typical accuracy ranges for Class 4 estimates are -15% to -30% on the low side, and +20% to +50% on the high side, depending on the technological complexity of the project, appropriate reference information, and the inclusion of an appropriate contingency determination. Ranges could exceed those shown in unusual circumstances.
Effort to Prepare (for US\$20MMproject):	Typically, as little as 20 hours or less to perhaps more than 300 hours, depending on the project and the estimating methodology used.

Reference: <http://oecm.energy.gov/Portals/2/g4301-1x.pdf>

## 5.0 Geographic Location Factor

As a part of the review of the study report Colt Engineering was asked to comment on and advise the consultant on the geographic location factor used in the cost estimating process.

The use of US Gulf Coast Construction Costs (USGC) as the global benchmark for capturing costs and the developing cost estimates is well established in the process industry. It is also well understood that for every location in the world the costs of construction vary due to a variety of factors such as: wages and benefits, taxes, labor availability, productivity, seasonal factors, etc. The factors used by companies in particular area might vary somewhat due their own assessment of each component factor that makes up the overall geographic location factor. The following is a used reference for understanding the application of the geographic location factor. <http://www.icoste.org/korev94.htm>.

The following comments can be made on this matter:

- Labor cost and productivity difference assumed by the consultant to be to be +30% over USGC which translates into ~+12-15% add to TIC.

The consultant has documented the build up of this in his report. Colt generally concurs that this factor is reasonable subject to several qualifying assumptions:

- This project assumes a more stable E&C environment (very oil price dependent), but includes a 5% per year compound escalation of capital cost during construction. Currently an uncompetitive E&C market exists within Alberta due to skilled labor shortages causing significant inflation in current project costs.
- Global procurement and engineering will be used on a project of this magnitude.
- Management of a project of this magnitude will use best practices in cost containment without sacrificing safety and quality.
- No unreasonable barriers will be encountered to the smooth execution of this project.
- The local infrastructure can stand up to a project of this size.

The current reality in major petroleum and petrochemical construction in the Edmonton region is that the geographic location factor applied and observed is more in the range of 1.25 to 1.4. It is beyond the scope of this review to detail all of the components that bring the observed factor up to these levels, but some significant contributors are illustrated in the table below:

### Build-up of Edmonton to USGC Cost Factor

	% of TIC	USGC to Edmonton Adjustment Factor	
Major equipment and bulk	52	1.1	Accounts for Local cost adders; taxes, duties, winterization etc.
Cost of transporting equipment	3	1.67	Tag items 5-8%/ bulk items 3-5%
Cost of Engineering	9	1.05	Current engineering labor supply penalty plus some productivity difference due to "new" engineers in work force
Cost of start up	1	2	
Cost of construction	35	1.69	1.25 X USGC= Basic Edm X 1.35 avg trade productivity difference (yearly average)
	100	1.33	

## 6.0 Reality of the Synergies and Resulting Cost Savings

The proposal includes several innovations that will lower the initial capital cost of the facility. These include:

- A central steam electric generating facility so that motive power for most prime movers is electric rather than high-pressure steam. This greatly reduces large bore steam and condensate piping and contributes to a lower cost of in unit piping and interconnecting piping
- Use of high reliability electric drives for large compressors
- Use of steam as the heat integration medium for the atmospheric and vacuum crude distillation units. This is made possible due to the relatively low cost of incremental steam via coal-fired boilers.

The capacity of the facility is synergist to integrated world scale for petrochemicals and ammonia production rejected carbon is fully utilized for heat, hydrogen and ammonia production. The novel approach to energy utilization, feedstock and intermediate product management and process unit integration does offer considerable scope for cost optimization on a facility of this magnitude and scope. Globally other integrated process facilities are in place in areas rich in either natural or human resource. There exists scattered throughout the Alberta process industry almost every element that makes up this integrated facility.

The key to the cost savings is in the integration and willingness to adapt technology in this way. This concept was conceived as a base case against which to test the economics of options. It represent one approach to increasing the value of Alberta's oil sands resource in a way that provides a higher level of return to the local economy.

As this is a conceptual study, additional detail is required to reduce the technical and economic risk prior to implementing the concept.