

ALBERTA SCALING MANUAL

Scaling Methods – CUBE SCALE

3.2 Cube Scale	2
3.2.1 General	2
3.2.2 Volume Determination	2
3.2.3 Numbering and Marking of Stacks	2
3.2.4 Measurement Procedures	3
3.2.5 Cube Scale Tally - Form TM258W	3
3.2.6 Defect Calculation	8

Archived

3.2 Cube Scale

3.2.1 General

Cube scaling is a method used to determine the volume of sound wood in a stack of cut-to-length logs (also called “bolts”). This method was developed as an accurate way to determine volumes without spreading out the bolts, thus making it efficient.

Like the Smalian method, cube scaling requires that every piece be measured.

Cube scaling can be used to determine the volume of sample loads for mass-scaling operations, but written approval from the Timber Scaling Supervisor of the PLFD must be obtained prior to adopting this method.

3.2.2 Volume Determination

Volume tables make it easy to look up volumes; see the Volume of Cylinders table in (Refer to Table 2 – Appendix 7). Sometimes, however, the volume(s) will have to be calculated. For ease of compilation, volumes are calculated 1000x using the following formula:

$$V = (A \times L) \times 1000$$

Where V = gross volume (1000x)
 A = basal area of the bolt face in m^2 (1000x)
 L = length of the bolt in m

The basal area, A , is calculated using the following formula:

$$BA = \pi \left(\frac{D}{200} \right)^2$$

Where BA = basal area in m^2 (1x)
 D = the diameter (in class) of the bolt end
 π = pi to 5 decimal places (3.14159)

3.2.3 Numbering and Marking of Stacks

Each stack of bolts will be identified. When scaling, each Bolt will be marked so that no log is missed or scaled twice. Cull bolts (see section 3.2.6) will be marked with an X across the log face.

3.2.4 Measurement Procedures

Bolts are most commonly measured in 2.4m or 2.6m lengths, and a scaler will check the accuracy of the bucking by measuring a few of the bolts. Bolts that are bucked to different lengths follow slightly different procedures (see below). All diameters are measured as per the diameter measurement procedures detailed in section 2.11.1.

2.4- AND 2.6-METRE LENGTHS - When bucked to 2.4m or 2.6m lengths, diameters are measured on only one side of the pile. It is assumed that there is an equal distribution of tops and butts on each end of the pile.

Each bolt's diameter is measured and the resultant volumes are referenced from the Volume of Cylinders - m^3 1000x table. Some mills have developed software similar to Mscale to compile cube scale volumes; such software must be approved in writing by PLFD prior to implementation.

Defect deductions are covered in section 3.2.6.

OTHER LENGTHS – When bolts are bucked in excess of 2.6m, both sides of the pile must be measured. The maximum length that can be Cube scaled is 5.0m.

After measuring a number of logs to confirm their length, the scaler must create volume tables using the formula in section 3.2.2.

Once volume tables have been created the scaler measures and tallies the diameters on both sides of the pile. Volumes are obtained from the volume table created for the specific bolt length of the stack, but because diameters are measured on both sides of the pile, two volumes for each log are obtained. To compensate for what seems like double accounting, the scaler will divide the net scale by two.

3.2.5 Cube Scale Tally - Form TM258W

Bolts are recorded and volumes calculated on form TM258W, the Cube Scale Tally Sheet. There are four sections on this form:

3.2.5.1 Header information

Header information must always be completed on each page of a sample load. This information identifies a load and allows for the tracking of scale data throughout the weigh scale/reporting process. There are 12 fields to complete in the Header section:

- a. DISPOSITION HOLDER – the name of the company or individual under whose name the disposition was issued.
- b. MILL NAME OR LOCATION – the name of the mill if different from the disposition holder, and/or the location of the mill.
- c. DISPOSITION – disposition numbers have ten characters. The first three define the type of disposition:

The remaining characters depend upon the disposition type, and are listed below:

- 1. FMA – the next two characters indicate the year in which the current agreement commenced. The remaining characters are sequential for all FMAs in the province.
 - 2. CTL, CTP, DTL, and DTP – the first character of the remaining seven indicate the forest; the following three characters indicate the management unit in which the disposition is located; and the last three characters indicate the disposition number.
 - 3. LTP – the remaining seven characters are sequential for all LTPs in the province.
- d. SOURCE – Depending upon the type of disposition, one of two pieces of information can be recorded in this field.

If a disposition is stratified into smaller units, such as working circles within an FMA, then the reference number for the unit shall be recorded in this field.

Or,

Non-disposition wood sources are indicated in this field. Non-disposition sources include private land, industrial salvage, etc, and the legal land description or special land use coding is used to identify the source.

- e. MILL NUMBER – the number assigned to the mill by the LFD.
- f. LOAD NUMBER – the sequential load number from a given population
- g. DATE WEIGHED – the date the load was weighed.

- h.** POP – the population number under which the load (and disposition) is included.
- i.** NET WEIGHT – the weight of the trees / logs / bolts from the load (kg).
- j.** TM9 NUMBER – the number on the haul form accompanying the load (TM9 or TM9A).
- k.** TOP – the minimum top size for the population as dictated by the utilization standard of the disposition(s) included in the population.
- l.** LENGTH – the specific length the bolts in a stack are all cut to (m).
- m.** SP CD PR – the primary species, condition, and product that makes up the majority of the bolts in a stack.

The following is an example of the Cube Scale Tally Sheet.

Archived





Cube Scale Tally Sheet

Disposition Holder Black Bear OSB			Mill Name or Location Slave Lake			Disposition DTLS040001			Mill Number 4392		Load Number 46		
Date Weighed 2 0 0 3 0 1 0 7			Pop 103	Net Weight (kg) 10120		TM 9 Number A 1 3 9 0 6 4			Top 12	Length 2.4	SP A	CD GR	PR 18
GROSS SCALE						DEDUCTIONS							
Dia.	Tally	Pieces	Vol/Pce.	Volume	PR	Dia.	Tally	Pieces	Vol/Pce.	Volume			
4						4							
6						6							
8						8							
10	••	2	19	38	99	10	••						
12	•••	4	26	104	06	12	••	2	26	52			
14	☒ ••	12	36	432	06	14							
16	☒ •••	14	48	672	06	16							
18	☒ ☒ ••	22	60	1320	18	18	••	3	60	180			
20	☒	10	74	740	18	20							
22	☒ ••	12	91	1092	18	22							
24	☒ ☒	20	108	2160	18	24	••	3	108	324			
26						26							
28	••	2	149	298	18	28							
30						30							
32						32							
34						34							
36						36							
38						38							
40						40							
42						42							
44						44							
46						46							
48						48							
50						50							
Totals													
Species Group 1:		AGR18		66		5610		8		556			
Species Group 2:		AGR06		30		1208							
Species Group 3:		AGR99		2		38							
TOTAL:				98		6856		8		556			
Net Scale 1000x (Gross Vol - Deductions):						6300		Net Scale 1x:		6.300			
Date Scaled:			Scaler:			Permit Number:							
2 0 0 3 0 1 2 2			M. Smith			9999							

Figure 3.30 – Cube Scale Tally Sheet

3.2.5.2 Bolt Tally

Each bolt's diameter is dot-tallied under the column entitled *Tally*. A 10-point grouping system is used:

1	•	6	
2	• •	7	
3	• • •	8	
4	• • • •	9	
5	•—• • •	10	

Once all the bolts have been dot-tallied, the number of pieces is entered under the column entitled *Pieces*.

The volume per piece is obtained from either the volume table or by using the formula, and these piece volumes are entered under the *Vol/pce* column.

Volumes are obtained by multiplying the number of bolts from each diameter class by their respective volume per piece value.

There is a column to change product code in the event that there is undersize or small stem wood present in the load.

3.2.5.3 Defect Tally

Section 3.2.6 details the actual defect calculations.

Defects are dot-tallied, counted and multiplied by a volume per piece value just as are bolt volumes.

3.2.5.4 Volume Summary

Once all bolts have been tallied and all volumes determined, the volumes are summarized at the bottom of the sheet(s). There is room for three SP CD PR groups, and volumes are totaled for each group.

Next, the defect volume is subtracted from the gross scale volume resulting in the net volume (1000x).

The final step is to divide the Net Scale (1000x) by 1000 in order to obtain the final Net Scale (1x).

3.2.6 Defect Calculation

Deductions are made only for soft rot and wood missing from the log end. The actual size of the defect is measured without any allowances (ie: **do not add 2cm** as in the the Smalian Scale).

No deduction can be made for mechanical damage.

When measuring one side of the pile (ie: lengths $\leq 2.6\text{m}$), defects are assumed to extend the full length of the bolt.

When measuring both sides of the pile (ie: lengths $>2.6\text{m}$), defects are assumed to extend half the length of the bolt.

A bolt is considered a cull bolt when the BA of the rot is greater than 50% of the BA of the bolt's face. In such cases the diameter of the bolt is tallied as opposed to the diameter of the defect, thus eliminating the bolt from the scale. A cull bolt is marked with an X across the log face.

Defects are tallied under the DEDUCTIONS column on the left side of the tally sheet.

3.2.6.1 Soft Rot

If the rot is round, then the diameter is directly measured (in diameter class). A basal area comparison is then done to determine if the rot's BA is greater than or less than (or equal to) the BA of the bolt face.

Example 1 - If the BA is less than or equal to 50% of the BA of the bolt face, then the diameter of the **rot** is tallied. For example:

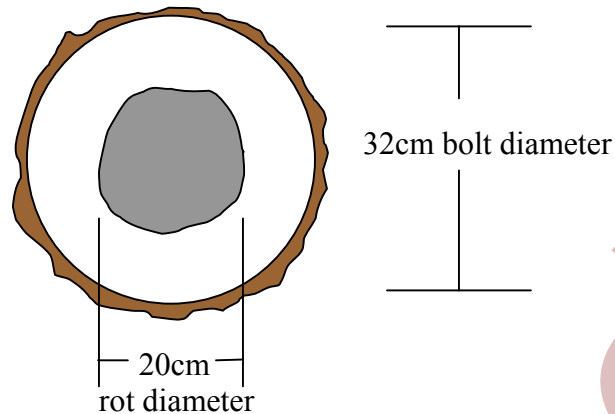

Figure 3.31 – Defect less than 50% of bolt basal area

1. The diameter of the bolt is measured and tallied, in this example, in the 32cm diameter class.
2. The defect is measured, but before tallying, the basal area comparison must be made.

Bolt diameter = 32cm = 80m² (1000x)

Rot diameter = 20cm = 31m² (1000x)

BA of the rot is therefore less than the BA of the bolt's BA

3. Since the BA of the rot is <50% of the bolt's BA, the diameter of the defect, 20cm in this example, is tallied in the *Deductions* column.

Example 2 - If the BA of the defect is greater than 50% of the bolt face then the diameter of the **bolt** is tallied (i.e.: cull log). For example:

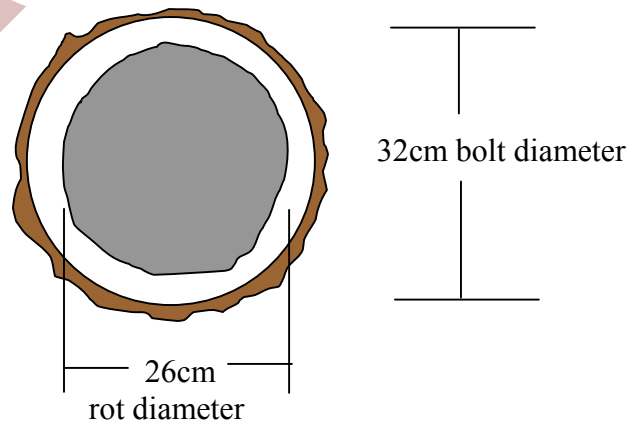

Figure 3.32 – Defect greater than 50% of bolt basal area

1. The diameter of the bolt is measured and tallied, in this example, in the 32cm diameter class.
2. The defect is measured, but before tallying, the basal area comparison must be made.

$$\text{Bolt diameter} = 32\text{cm} = 80\text{m}^2 (1000\text{x})$$

$$\text{Rot diameter} = 26\text{cm} = 53\text{m}^2 (1000\text{x})$$

BA of the rot is therefore greater than 50% of the bolt's BA

3. Since the BA of the rot is >50% of the bolt's BA, the bolt is considered a cull bolt; therefore, the diameter of the **bolt** is tallied in the *Deductions* column.

Example 3 - If the rot is irregularly shaped, then the diameter is obtained by multiplying the height (m) and width (m) of the rot. Next, by referencing a basal area table or by working backwards with the basal area formula, the equivalent diameter is found.

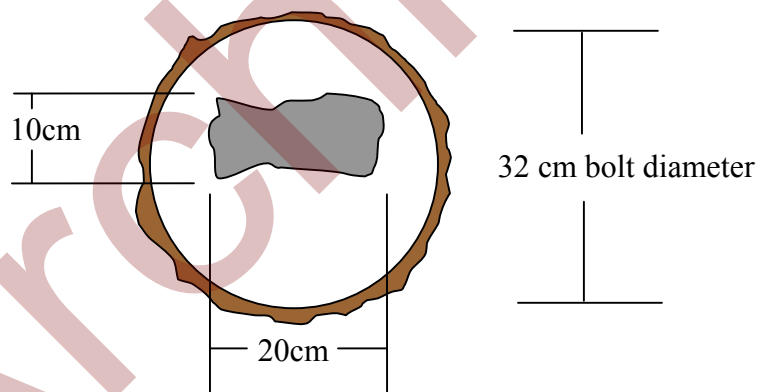

Figure 3.33 – Irregular Shaped Defect

1. The diameter of the bolt is measured and tallied, in this example, in the 32cm diameter class.
2. The defect diameter is determined by first multiplying the width (m) and height (m) of the defect.

$$0.10\text{m} \times 0.20\text{m} = 0.020\text{m}^2 (1\text{x})$$

3. The calculated basal area (1x) is then converted to an equivalent diameter by either referencing a basal area table, or by using the BA formula. In this example the BA of 20m² (1000x) can be

referenced on the *Basal Area – 1000x* table (See Table 1 – Appendix 7), and the equivalent diameter of 16cm can be obtained.

4. Before tallying the defect the basal area comparison must be made.

Bolt diameter = 32cm = 80m² (1000x)
 Rot diameter = 16cm = 20m² (1000x)
 BA of the rot is therefore less than 50% of the bolt's BA

5. Since the BA of the rot is <50% of the bolt's BA, the defect diameter, 16cm in this example, is tallied in the *Deductions* column.

If the BA of the irregularly shaped rot is greater than 50% of the bolt's BA, then the bolt is considered a cull bolt, and the diameter of the **bolt** is entered in the *Deductions* column.

3.2.6.2 Missing Wood

To account for missing wood, a diameter equivalent is estimated and tallied in the *Deductions* column. For example:

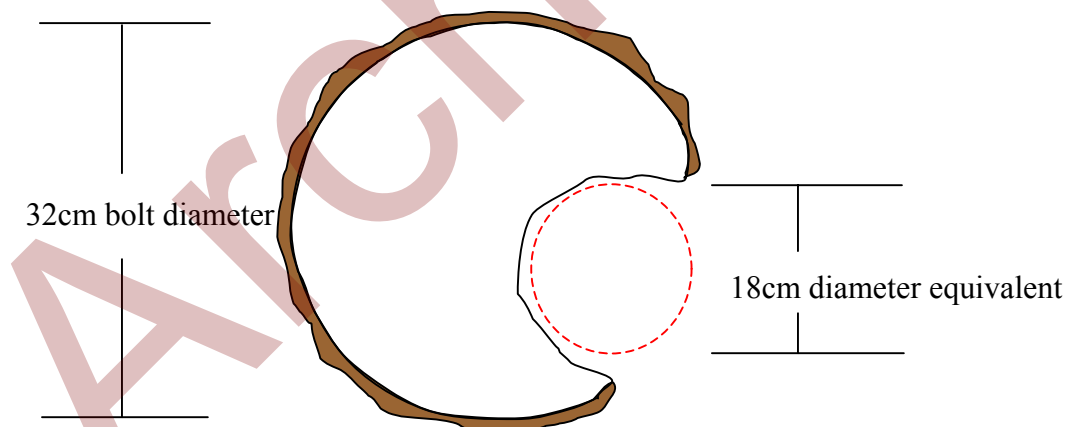

Figure 3.34 – Missing Wood Defect

1. The diameter of the bolt is measured and tallied, in this example, in the 32cm diameter class.
2. An estimate is made as to what diameter bolt could best fit into the area of missing wood.
3. The diameter of the estimated diameter equivalent, 18cm in this example, is recorded in the *Deductions* column.