

PARKS AND PROTECTED AREAS

# Written in Stone



This publication is part of a series of field study programs produced by the Environmental Education Program of Parks and Protected Areas in Kananaskis Country and Fish Creek Provincial Park. These publications have been written to address the goals of Alberta Community Development and increase students' environmental awareness, understanding, interaction, and responsibility for the natural world in which they live.

The publications are developed in a close working relationship with teachers, community educators and program writers. Programs focus on the areas of environmental education, science, social studies, and language arts. They are also developed to emphasize elements of environmental literacy, lifestyle, and citizenship.

This material may be freely copied for educational use provided the source is acknowledged.

For more information contact:

Environmental Education Specialist  
Parks and Protected Areas - Kananaskis Country  
Suite 201, 800 Railway Avenue  
Canmore, AB. T1W 1P1

Telephone: (403) 678-5508 (toll-free within Alberta 310-0000)  
Internet: [www.cd.gov.ab.ca/parks/kananaskis](http://www.cd.gov.ab.ca/parks/kananaskis)

### **Written in Stone**

ISBN: 0-7785-0890-0 Pub. No.:I/787 (printed edition)  
ISBN: 0-7785-0891-9 Pub. No.:I/787 (on-line edition)

Copyright © 2002 Government of Alberta



# TABLE OF CONTENTS

1.0 Overview	1
1.1 At a Glance	1
1.2 Program Summary	2
1.2.1 Trip Itinerary	2
1.3 Program Objectives	4
1.4 Curriculum Tie-ins	4
2.0 Field Study: Preparation and Materials	5
2.1 Materials	5
2.2 Preparation	8
3.0 Field Study:	10
3.0.1 Road Log: Calgary to Barrier Lake	10
3.1 Stop #1: Deposition of Sediments	14
3.1.1 Background Information	14
3.1.2 Activities	15
3.1.3 Challenge Questions	20
3.1.4 Road Log: Barrier Lake to Ribbon Creek	22
3.2 Stop #2: Formation of Rocks	24
3.2.1 Background Information	24
3.2.2 Activities	24
3.2.3 Challenge Questions	28
3.2.4 Road Log: Ribbon Creek to Galatea Parking Lot	31
3.3 Stop #3: Mountain Building	32
3.3.1 Background Information	32
3.3.2 Activities	37
3.3.3 Challenge Questions	40
3.3.4 Road Log: Galatea Parking Lot to Lower Lakes Day Use Area	42
3.4 Stop #4: Erosion	44
3.4.1 Background Information	44
3.4.2 Activities	47
3.4.3 Challenge Questions	51

4.0 Glossary of Terms 52

**5.0 *Written in Stone*** - Evaluation Form 54

## Appendices

- I Home Made Modelling Clay Recipe
- II Activity: How to make a Mountain of Jello
- III Geological time and Kananaskis Country
- IV **Rock Notes** - Student Manual

# 1.0 OVERVIEW

## 1.1 AT A GLANCE

---

**TOPIC**

Geology

**GRADE/AGE LEVEL**

Grade 7 - 8 / ages 12 - 14

**TIME REQUIRED**

Full day field study (7 hours)

**BEST SEASON**

Spring or fall

**STAFF REQUIRED**

1 leader plus adult volunteers. Kananaskis Country recommends an adult/student ratio of 1:10

**SUGGESTED FIELD LOCATIONS IN KANANASKIS COUNTRY**

This field program follows a route which leads from Calgary to Peter Lougheed Provincial Park along Highway 1 and Highway 40, with four stops along the way.



## 1.2 PROGRAM SUMMARY

*Written in Stone*, a full-day field program for students at the Junior High School level, examines the geologic landforms between Calgary and Peter Lougheed Provincial Park. The program consists of a road log and four stops. The road log contains information on the landforms visible from the highway and poses questions for discussion; the four stops represent four chapters in the geology of the Rocky Mountains - deposition, rock forming, mountain building and erosion. During each stop, students participate in an activity which demonstrates the geologic processes.

Students are guided through the day with a student booklet entitled *Rock Notes*, used in conjunction with *Written in Stone*, the teacher's manual. Although the route follows the Trans-Canada highway to Peter Lougheed Provincial Park, the techniques used in the field program can be modified to suit other mountain areas.

The material in this manual is organized according to the four stops of the field study. Each stop begins with background information pertaining to the theme of that stop (e.g., Mountain Building), describes the activities that take place, and ends with challenge questions that students can answer while en route to the next stop, or in the classroom. A road log describing the geology between stops completes each subsection.

To foster an awareness of and an interest in the study of Earth Science, *Written in Stone* can be conducted as a pre-unit introduction or as a post-unit review of Earth Science. Teachers may also conduct the program during an Earth Science unit to provide first-hand contact with the topic of study.

### 1.2.1 Trip Itinerary

#### Stop One - Deposition (Barrier Lake Boat Launch)

After students have followed the road log from Calgary to Barrier Lake, they participate in a discussion and activity that illustrate processes of sedimentation. These processes aided in the creation of the Rockies as we know them today.

Barrier Lake is an ideal location to introduce the program, as water is an essential component of the processes described in this stop. Actual examples of stream deposition can be seen east of the boat launch, and the materials required for the class activity (water and different types of sediment) are also readily accessible.

### **Stop Two - Formation of Rocks (Ribbon Creek Parking Lot)**

At this stop, a discussion on how sediments turn to stone is followed by a class activity called *The Rolling Stone Game*, which demonstrates this geological process. Other activities have the students using their senses to aid in the identification of various rock types.

This site has a large open space that is required for the class activity. In addition, rocks for the rock identification activity can be found along Ribbon Creek or at the Ribbon Creek hiking trailhead. A nearby picnic shelter is open for public use and provides an ideal location for a lunch break.

### **Stop Three - Raising the Rockies (Galatea Parking Lot)**

At this stop, a discussion on isostatic rebound and plate tectonics is followed by an activity that assists students in understanding the forces that have shaped the Rockies. The large syncline-anticline structure seen on the north face of Mt. Kidd provides an excellent backdrop to this stop: the twisted and contorted features of the rock face are an impressive testimony to the forces that can occur within the earth.

### **Stop Four - Erosion (Lower Lakes Day Use Area)**

This stop focuses on the various weathering and erosional processes which change the earth's surface. Students observe first-hand the sediment load carried by Boulton Creek, experiment with differential erosion rates using layered cookies, and identify various glacial landforms found in the mountains around them. In the mountain panorama of this site, examples of all of the processes discussed during the field study can be seen. By observing the sediments transported by Boulton Creek, students come to realize that the cycle of mountain building is a never-ending, continual process, as active today as when the Rocky Mountains first started being formed 65 million years ago.

Note: for the field study today, students will need to have their Time Ropes available, so that they may refer to them when the different geologic periods are mentioned.

## 1.3 PROGRAM OBJECTIVES

This field program was developed with the following objectives in mind:

1. Students will understand that the crust of the earth is in a constant state of change.
2. Students will participate in activities that illustrate the natural processes observed during the field program.
3. Students will discover that the key to understanding the processes that have formed the Rocky Mountains is understanding how modern-day earth processes interact with each other.
4. Students will become more aware of the geology and physiography of Kananaskis Country.
5. Students will appreciate that there is more to a rock than meets the eye...

## 1.4 CURRICULUM TIE-INS

This program supports much of the Earth Science curriculum outlined in the Alberta Curriculum for Division III Science. The specific topics addressed are described below.

Grade	Science Curriculum Concepts
7	<b><u>Topic 6: Evidence of Erosion</u></b> <i>Written in Stone</i> addresses the following concepts found in Topic 6: the formation of glacial and fluvial landforms, and the various mechanisms of erosion and its effects.
8	<b><u>Topic 4: The Earth's Crust</u></b> All three major concepts addressed in this topic (evidence of earth changes, rock identification, the importance of sedimentary rocks) are covered by the <i>Written in Stone</i> program.



# 2.0 PRE-PROGRAM: MATERIALS AND PREPARATION

## 2.1 MATERIALS

### For the Teacher:

- Kananaskis Country *Earth Science Teaching Activity Guide* (elective).
- Written in Stone*, the teacher's guide and answer key to the field program.

### For each student:

- Student booklet, entitled *Rock Notes*.
- A daypack containing a clipboard, pens or pencils, lunch, and rainwear.

### STOP #1

- Class set of "Time Ropes", prepared before the field study day (see Preparations, Section 2.2).
- 1 clear glass jar per student.
- Bicycle pump
- 5 plastic self-sealing bags per student for holding sediment samples.

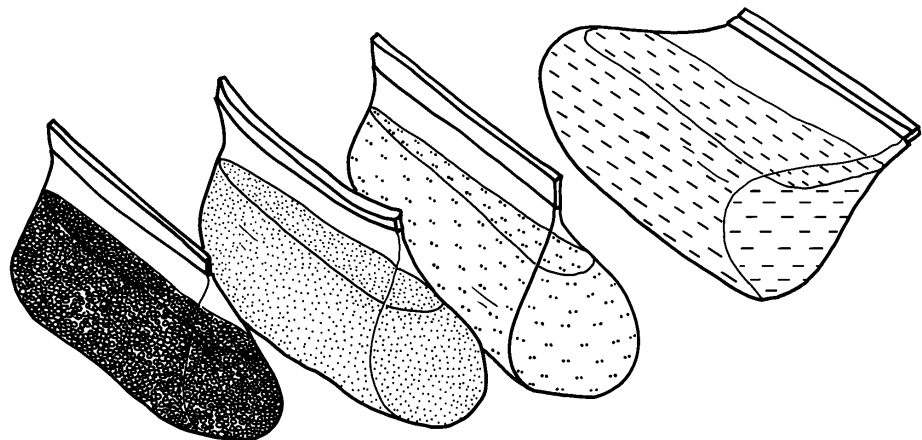
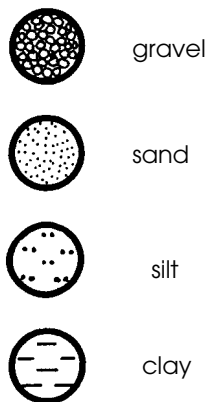

### **STOP #1**

- 100 ml weak hydrochloric acid (5%). It is recommended that the acid be used solely by teachers.
- Bicycle pump.

### **STOP #3**

- 1 sheet of construction paper (at least 11x17" (28 x 43 cm)).
- Balloon filled with water.
- Approximately 500 grams of clay for each student.  
Purchase some modelling clay from a local art supply store. One 20 kg box of clay is sufficient for 40 students. Alternatively, home-made clay can be made (see Appendix II for recipe). The clay is used at Stops 3 and 4, and can be re-used after the field study.
- The "Geologic Road Map of Alberta" (elective). This map may be obtained from:

The Canadian Society of Petroleum Geologists  
Room 505, 206 - 7 Ave. S.W.  
Calgary, Alberta  
T5P 0W7  
Phone: (403) 264-5610 .

- Lansat 5 satellite lithograph "Calgary / Banff from Space" (elective).  
This satellite photo resembles a photograph, and is very appealing to students. The alternating ridges of snowy peaks and green valleys shown in the most recent version show the ridge pattern very clearly. It is carried in many bookstores, or may be obtained directly from:

Advanced Satellite Productions Inc.  
1198 Raymer Avenue  
Kelowna, BC. V1Y 5A1  
Phone: (604) 270-4648

#### STOP #4

- 10-15 clear plastic cups.

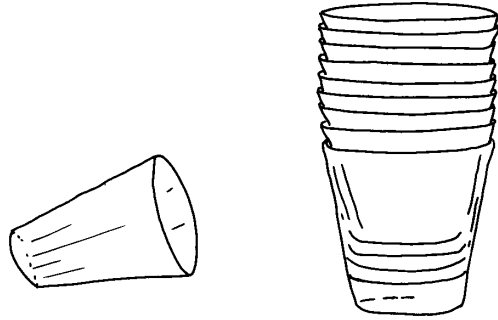

- Sharp rock flakes for carving clay (elective).
- Ice cream wafers or “layered” cookies (elective).

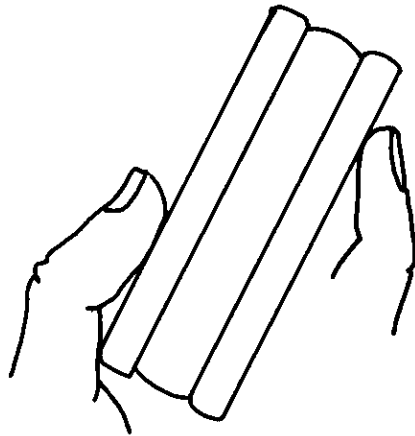

## 2.2 PREPARATION

- 1 In preparation for the field program, have your class complete activity **1.1.8 - Make a Time Rope**, from the *Kananaskis Country Earth Science Teaching Activity Guide*. Appendix III of *Written in Stone* also contains a table which can be used to construct a time rope. The completed time rope may be used during the program, where reference is made to specific geologic time periods.
- 2 **It is highly recommended that teachers drive the field program route and preview the field study beforehand.** Familiarize yourself with the *Written in Stone* program: the route, the road log, the activities, and the four field study stops. Check with personnel at Peter Lougheed Provincial Park (591-7222) to ensure that the roadway leading to the Lower Lakes Day Use Area will be open when your school group arrives.
- 3 Gather the materials listed in Section 2.1. Please note that many of the materials are optional.
- 4 If time permits, any of the following activities from the *Earth Science Teaching Activity Guide* can be conducted before the field study, to provide students with extra background knowledge:

### Recommended Pre-Field Study Activities

- a) Measuring Time (1.1.1)
  - b) Making Clocks (1.1.2)
  - c) Estimating a Million Years (1.1.4)
  - d) What Does a Million Look Like? (1.1.5)
  - e) The Sequence of Earth History (1.1.6)
  - f) Geologic Calendar (1.1.7)
  - g) Drilling through Time (1.2.2)
  - h) Stop the Clock (1.2.3)
  - i) Building Blocks for Rocks (3.2.1)
  - j) Recipe for Rocks (3.3.1)
  - k) Life from the Past (1.2.1)
  - l) Identification of Common Rocks in Kananaskis Country (3.3.5)
  - m) Rivers: Water, Rocks, and Energy (2.2.7)
- 5 Decide on a suitable post-field study activity. Suggested activities from the *Earth Science Teaching Activity Guide* include:

### Recommended Post-Field Study Activities

- a) River Tumbling (2.2.3)
- b) Making a River (2.2.4, 2.2.5)
- c) Making River Landforms (2.2.6)
- d) Disappearing Glaciers (2.2.10)
- e) Glacial Erosion (2.2.9)

- f) Building Blocks for Rocks (3.2.1)
- g) Rock Cycle (3.3.2)
- h) Making Acid Rain (2.1.4)
- i) Messing Around with Mountains (2.3.2)

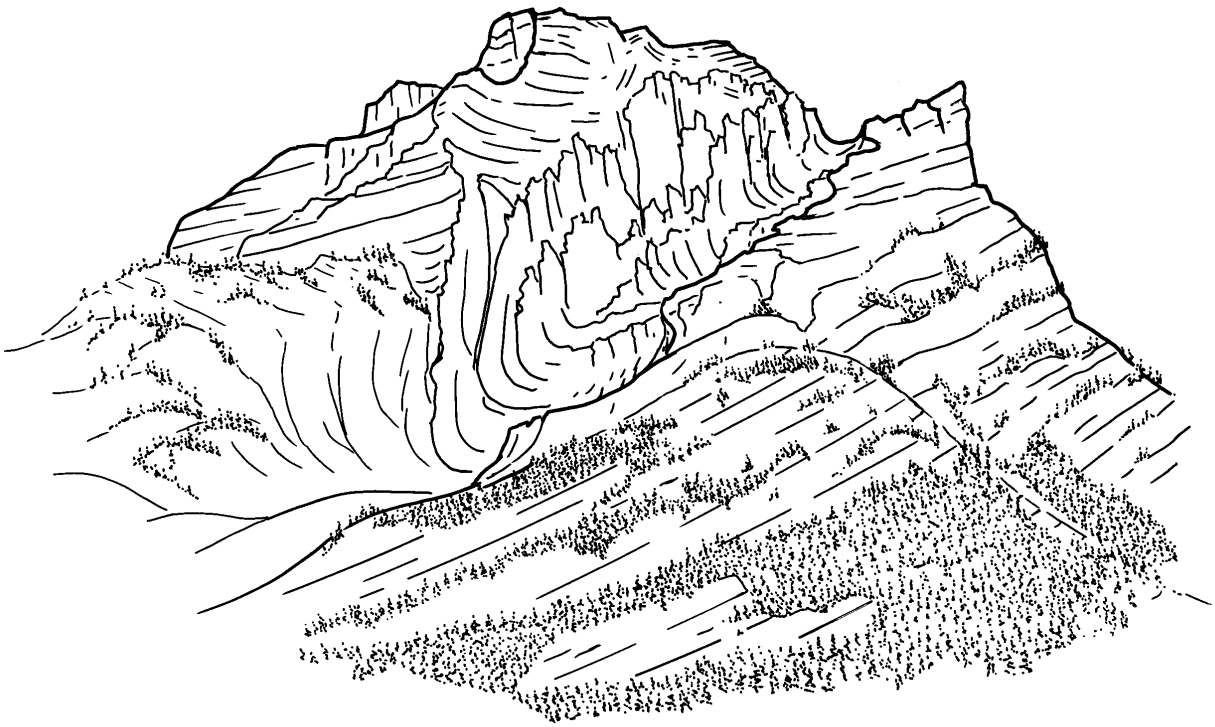

## 3.0 FIELD STUDY

The program *Written in Stone* contains two related components: the teacher's manual *Written in Stone*, and the student's manual *Rock Notes*. The two manuals are based on the same material, but have two noticeable differences:

1. The teacher's manual contains teacher-led activities that are described in detail in the Activities section.
2. The teacher's manual provides answers for all of the questions that are posed in the student manual.

This additional information, where it is included in the teachers manual *Written in Stone*, is printed in different type.

The structure of the student's manual *Rock Notes* has been designed so that the student can find all of the field activities and the road log in the same section. The section on background information (and the section containing extension questions, if it is not used) may be recycled by teachers from year to year.

### 3.0.1 ROAD LOG - CALGARY TO BARRIER LAKE

The following road log is designed for use by the students when they are on the bus. The only time that students need to disembark from the bus is at one of the four scheduled stops; however, several drawing activities have been provided in this road log which might easier be done from a stationary vehicle.

<u>Km</u>	<u>Comments/Questions</u>
0	Intersection of Trans-Canada Highway and the entrance to the Canada Olympic Park (traffic light location). If you have a trip odometer, set it to zero here.
3.0	Valley Ridge Overpass
3.7-3.8	To the right you can see a large valley with a smaller valley cut into it. What do you think would cause this to happen? <i>The larger valley was formed by large volumes of glacial meltwater at the end of the last ice age. The second valley is smaller because it was carved by relatively smaller volumes of more recent runoff.</i>
18.8	Geologists claim that by examining the road cut to the right they can tell that a very large lake once existed in this area. On what grounds do you think they could make this claim? <i>They could make this claim if they found extensive deposits of fine-grained materials (such as clay) that would have been deposited on the lake bottom.</i>

- 25.2 (Jumping Pound Creek bridge)  
 We are at the spot where, unseen beneath our feet, the Plains turn into the Foothills. The rock layers beneath the ground surface begin to show the bending and deformation caused by the same forces that built the Rocky Mountains.
- The bedrock is Cretaceous in age. This means that these rocks were formed at the time that dinosaurs became extinct. A thin layer of a rare metal called Iridium was deposited in the rock layers at this time, and it has led scientists to believe that the extinction of the dinosaurs was caused by a huge meteorite made out of Iridium that struck the earth around 65 million years ago.
- How could a meteorite hitting the earth have caused the extinction of all of the dinosaurs?  
*The force of the collision could have thrown up a huge cloud of dust that blocked the sun's energy from reaching the earth, created a long, cold "winter" on earth that killed the dinosaurs.*
- 27.2 The outcrop of rock to the right belongs to the Cretaceous period discussed above. These rocks were formed from sediments that probably lay along the shoreline of an ancient river, lake, or sea. How can we tell from looking at the rocks that they were formed along an ancient shoreline?  
*The rocks are sandstones, composed of sand grains that were deposited along a shore and were subsequently turned into rock.*
- 31.7-32.2 (Shell Oil's gas and sulphur plant to the right)  
 At this very moment you are driving over the Jumping Pound Gas Field. This field was discovered in 1944 and produces natural gas from rocks that were formed during the Mississippian age (approximately three hundred million years ago). During the Mississippian age, Alberta was submerged beneath inland tropical seas and swamps. These rocks now lie approximately three to four thousand feet below you.
- 38.0-38.4 On the left hand side of the bus, you can see sedimentary rocks that have been tilted from their original horizontal position by the same forces that created the Rocky Mountains.
- 39.1 Scott Lake Hill  
 This hill is the second highest point on the Trans-Canada highway, after the Rogers Pass. Did you feel your ears "pop" due to the decreased air pressure?
- 45.4-48.6  
 (and 49.0) A **drumlin** is a low hill that is created by a glacier, and is shown on the next page.



### Drumlin - from the Trans-Canada highway, looking north

When a glacier moves over the ground, sometimes it ploughs the earth into smooth shapes beneath it. One of these shapes looks like an upside-down spoon, and is shown above. It is called a drumlin.

Show the direction of movement of the glacier using an arrow (hint: in this area, the glaciers moved in a west-to-east direction). Where do you think the glacier that formed this drumlin came from?

*In the above diagram, the glacier moved from left to right. The glacier that formed this drumlin flowed from the Bow valley eastward onto the plains.*

- 49.1 Overpass to Morley and Chief Chiniki restaurant
- 49.9 Look at the material exposed beside the road to your left - it looks as if a gravel truck dumped it there. A large glacier dumped its load of **glacial till** here. Any material that has been transported and deposited by a glacier is called **glacial till**.
- 59.7 Second overpass to Morley Reserve.
- 58.1-60.1 More drumlins.
- 62.8 Turn-off to Highway 40 and Kananaskis Country - turn south here.
- 64.0 Interpretive sign on the right side of the road - **stop here** in the roadside space provided for vehicles.

You can see Mt. Laurie, also known as Mt. Yamnuska, to your right. Mount Yamnuska can be called a "split-level" mountain, because it has two distinct levels. The steep cliffs above are Cambrian in age (approximately 550 million years old), and are the oldest rocks found in Kananaskis Country. The gradual slopes underlying the cliffs are composed of younger rock, and were formed when mountain building was just beginning in Alberta - around 78 million years ago, during the Cretaceous age.

In a typical sedimentary bed, would you find older rocks overlying younger rocks?



No. One normally expects to find younger rocks overlying older ones - however, you can find older rocks overlying younger ones where a fault (a break in the rock) has thrust the deeper, older rocks up and over a deposit of younger rocks.

Sketch Mount Yamnuska in the space provided. Label the Cambrian rocks, the Cretaceous rocks, and the location of the fault that separates the two.

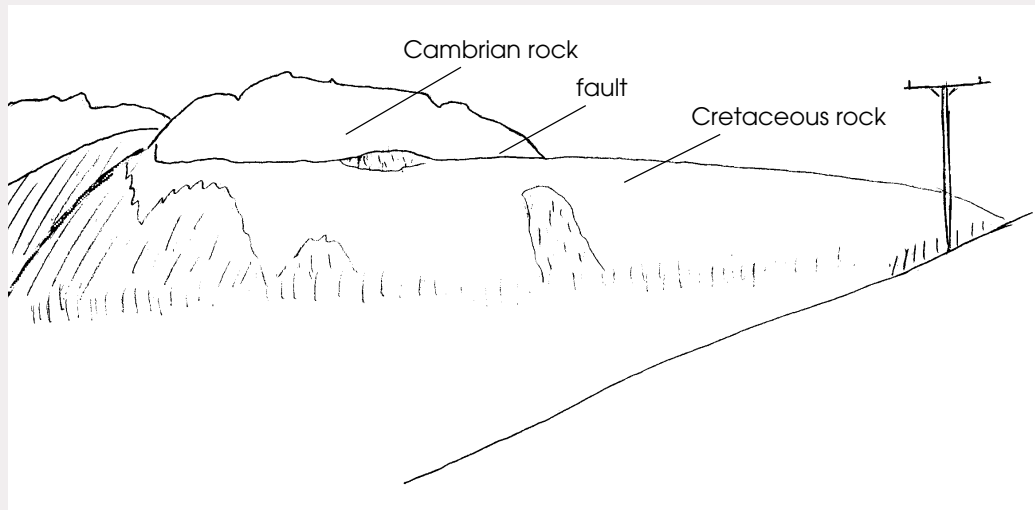

### Sketch of Mount Yamnuska from Highway 40

Read the interpretive sign. Now look at the land around you. Why do you think we normally find clay deposits in very flat-lying areas?

*The clays were deposited at the bottom of a glacial lake. The constant deposition of clay tends to smooth out the original contours of the lake bottom, creating a very flat-lying area.*

- 71.4 You have now officially entered Kananaskis Country!
- 72.9 Geologists speculate that this area was once covered by a large glacial lake called Sibbald Lake. How do you think they know this? (Hint: if geologists made a soil map of this area, they would be able to tell from the map how large the lake was).  
*By mapping the spatial distribution of the clay that was deposited beneath Sibbald Lake, geologists can determine where it once lay.*
- 74.5 McConnell Ridge to your right (also known as Barrier Lake lookout) is another example of a "split-level" mountain. The steep upper cliffs of this mountain are Cambrian aged, while the slopes below are younger Cretaceous-aged rocks - just as was the case for Mt. Yamnuska.
- 76.9 Turn-off for Stop #1: Barrier lake Boat Launch.

## 3.1 STOP #1: DEPOSITION OF SEDIMENTS

### 3.1.1 BACKGROUND INFORMATION

The story which will unfold during this field program began 350 million years ago, when most of Canada (including Kananaskis Country) was covered by a warm, shallow, tropical sea. This sea was bordered by lands to the north, east, and west. As the land was exposed to wind and water, it gradually wore down and was transported by rivers to the sea. Over hundreds of millions of years, billions of tonnes of sediments (gravels, sands, silts and clays) were deposited layer upon layer on the sea bottom.

As the rivers flowed, they had enough energy to carry quite a sediment load; but upon reaching the sea, the current that provided the energy to carry the sediments was lost. Heavier sands and gravels settled to the bottom first. However, lighter silts and clays remained suspended in the water for a longer time, and so eventually settled to the bottom at greater distances from the river mouths. Eventually, large deltas formed at the mouths of these rivers where the rivers flowed into the shallow seas.

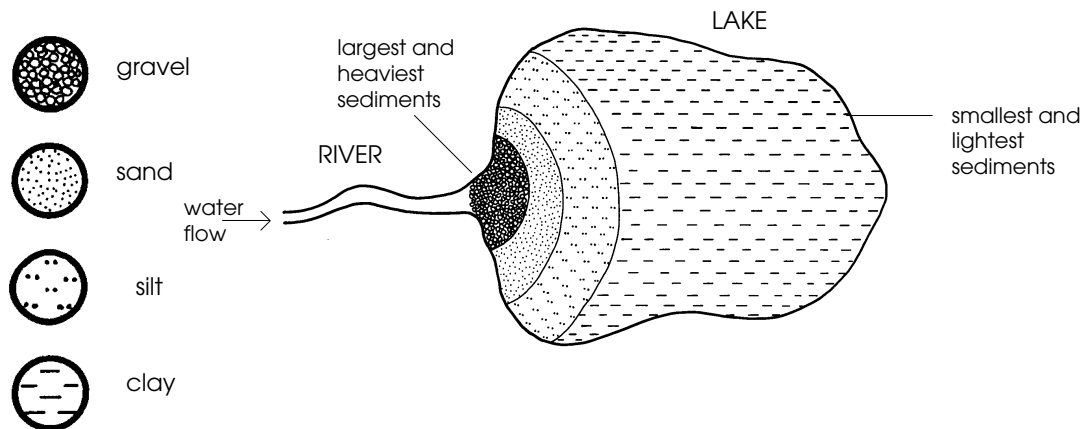

#### Sediments deposited in a delta

In the clear, shallow areas of the oceans not influenced by river sediments, marine organisms thrived and coral reefs formed. These areas were known as life zones.

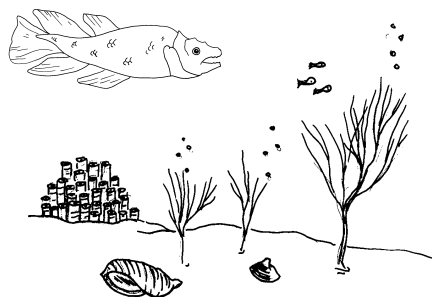

#### "Life Zone"

Many of these marine animals had shells and skeletons made of the mineral calcium carbonate ( $\text{CaCO}_3$ ). When these organisms died, their shells and skeletons accumulated on the ocean floor. Through time, this organic material was gradually broken down into smaller and smaller pieces by the gentle rolling action of the water on the ocean bottom, eventually becoming “calcite sediments”.

Over time, the deposition of various types of sediments (clay, silt, sand and gravel) created layers on the ocean floor. This horizontal layering (like a layer cake) is called **bedding** or **stratification**. The divisions between the different types of sediment layers are called **bedding planes**.

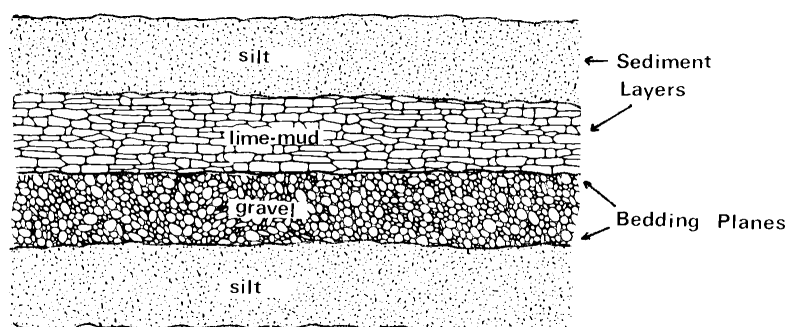

### Stratified Sedimentary Beds

As this process continued, younger layers were deposited on top of older layers. This same layering process can be seen happening today in the oceans and seas, and even in Barrier Lake. You can actually see the Barrier Lake delta forming at kilometre 80.4 of the field study today.

### 3.1.2 ACTIVITIES

#### Instructions for the Teacher

To begin Stop #1 activities, have all of the students line up along the edge of the Barrier Lake Boat Launch parking lot, at the farthest point from the boat launch (i.e., close to where the road enters the parking lot). As they face the boat launch, they should be able to see two things: the **No Parking** sign beside the boat launch; and McConnell Ridge, directly past this sign, on the opposite shore of Barrier Lake.

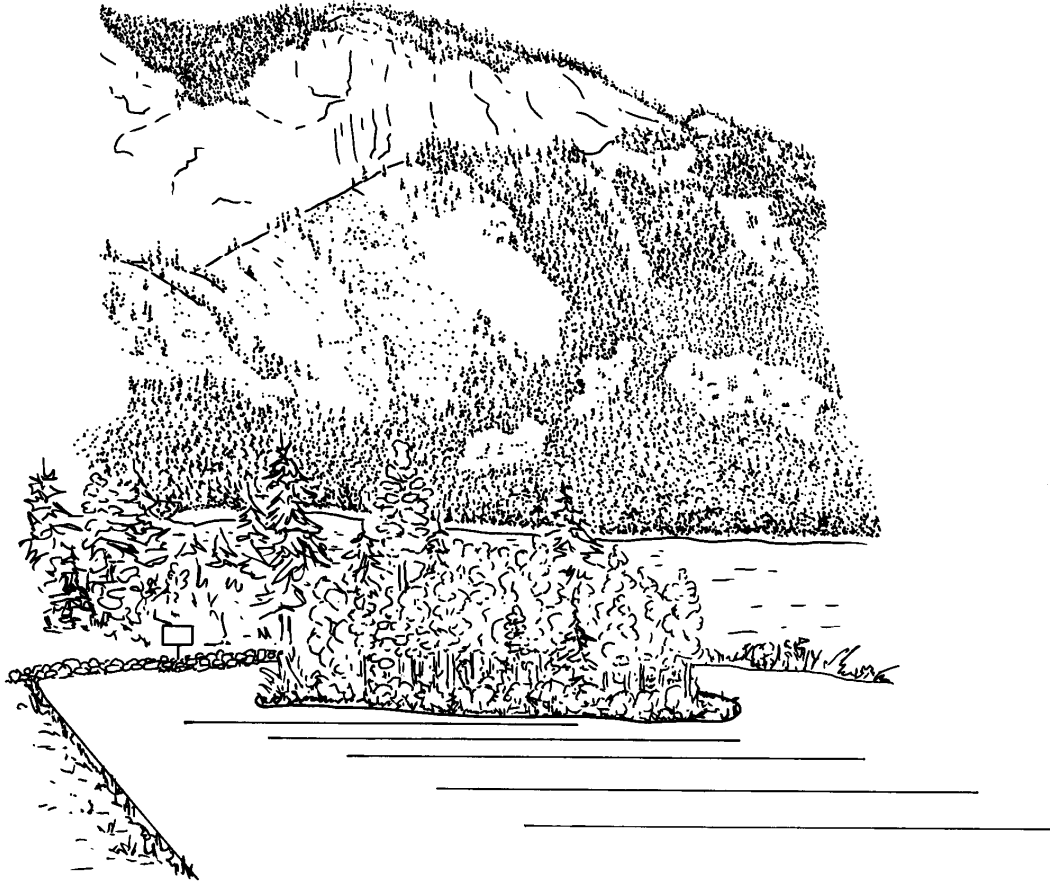

### **View from the edge of the Barrier Lake parking lot, looking north-west**

*Ask the students to imagine that the distance between where they are standing and the No Parking sign (exactly 100 metres) represents the entire age of the earth - all 4.6 billion years. They are standing at the beginning of time; the sign is at modern time. Then ask them to examine the mountain on the other side of Barrier Lake: the upper portion of this mountain consists of some of the oldest rocks found in Kananaskis Country. Ask them to walk to the position along the time line where they think these rocks were first formed from sediments. When they have all walked a certain distance, walk to the correct spot, and indicate that the group should join you there.*

*Complete this activity by demonstrating other significant events in Kananaskis Country, using the table below. Appendix III, **Geologic Time and Kananaskis Country**, offers additional information that can be used to construct time tapes.*

# of metres	# of paces	age (millions of years)	Event
88	54	570	oldest rocks in Kananaskis Country
98	60.8	65	youngest rocks in Kananaskis Country (also the beginning of mountain building)
99.4	61.6	2	beginning of glacial age - also first evidence of <i>Homo sapiens</i>
99.9	61.99	.01	end of last ice age (10,000 years ago) - also, man enters Kananaskis Country
100	62	present	

**Table 1: Stop #1 Activity: Kananaskis Country Geological History**

Following this activity, the Time Rope can be displayed in order to present the information to visual learners. After completing the Time Rope activity, have the students gather on the shore of Barrier Lake to conduct the next activity.

### **Instructions for the Student**

1. Find a partner for this activity.
2. Each partner should fill a jar three-quarters full with water from Barrier Lake.

**CAUTION:** The shoreline of Barrier Lake slopes steeply away underneath the water. Ensure that the students stay well away from the edge of the water.

3. There are four sizes of DRY sediment that can be found around this shoreline: gravel, sand, silt, and clay. Collect a sample of each kind, and place each type of sediment in a separate bag.

**How to tell sediments apart:** Gravel and sand can be distinguished on the basis of size. (Gravel diameters may vary between 2 and 20 mm; sand size varies between 0.0625 mm and 2 mm). Clay usually appears as a very blocky and cohesive unit that clings together until added to water, and feels somewhat greasy to the touch. Silt grains are intermediate in size between clay and sand (it measures 0.004 to 0.0625 mm

in diameter); silt grains are too small to be seen clearly with the naked eye, but do not share the blocky and cohesive nature of clay.

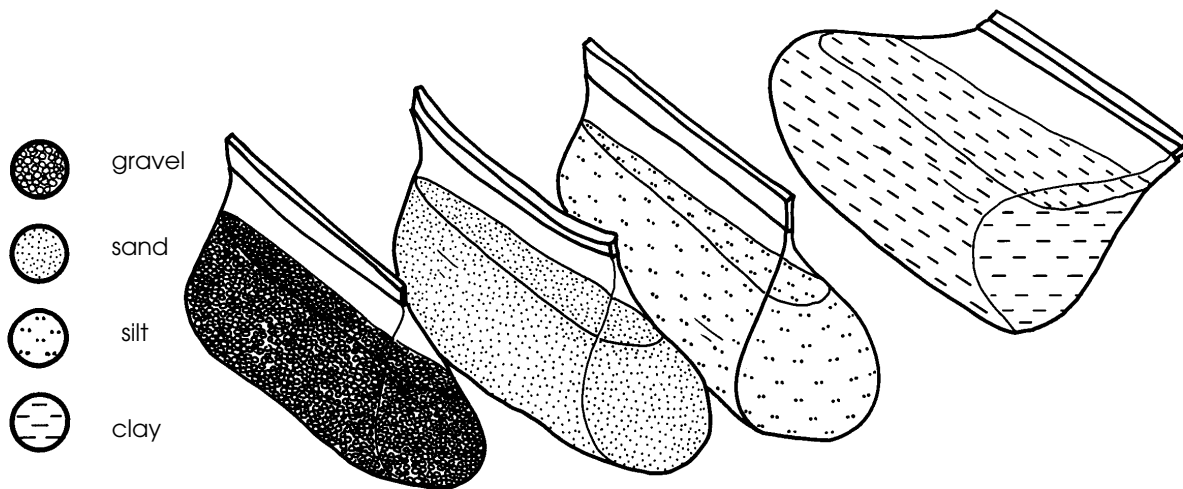

4. For each sediment type: fill your jar lid with sediment so that the soil is level with the lid of the jar. Then, drop the sediment into the jar. (Note: for the clay and silt, rub it between your hands so that it is not all stuck together). Observe the different rates at which they settle. In the space below, record your observations:

*Sediments settle at a rate proportional to their size. Therefore, gravels settle fastest, followed by sand, silt, and clay.*

**Note to Teacher:** Clay (and to a much lesser extent silt) are both cohesive; unless the students rub these materials between their hands, the materials will tend to stick together (cohere) and will settle faster than an individual grain would.

5. Measure out another “level jar lid” of each sediment type, and mix them thoroughly together in your spare bag. Drop this mixture into the water in the second jar, shake vigorously for ten seconds, and wait five minutes. BEFORE you actually do this, however, PREDICT what sediment layers will form on the bottom of the glass jar, based on your results in #4.

My prediction:

*A correct prediction would be that sediments would sink to the bottom faster if they are larger. This is because the ratio of surface area to mass is smaller for a larger particle. The gravel should therefore be found at the bottom of the jar, followed by sand, silt, and clay in that order.*

On the jar illustrated below, draw the different sediment layers as they form, using the following symbols to represent the sediment types:

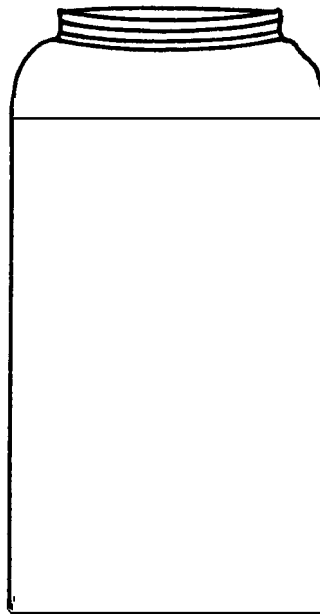
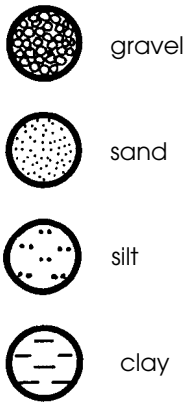

**Jar of Sediment**

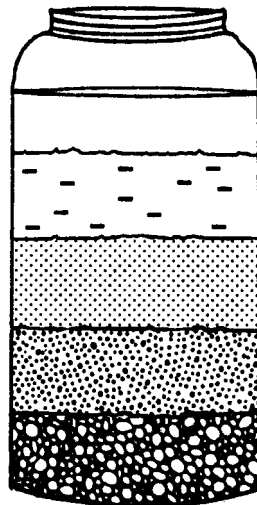
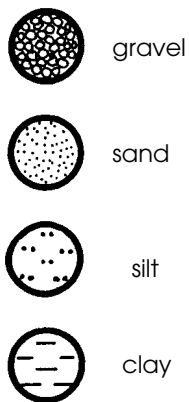

**Jar of Sediment - Teacher's Answer**

### 3.1.3 CHALLENGE QUESTIONS

1. The level of an ocean's shoreline constantly fluctuates for a variety of reasons. As a result, the same offshore area will receive not just one type of sediment over the years, but an assortment of sediment types, as illustrated below. Interpret the history of the area illustrated by looking at how the sediment was deposited. Why were different sediments deposited in different places?

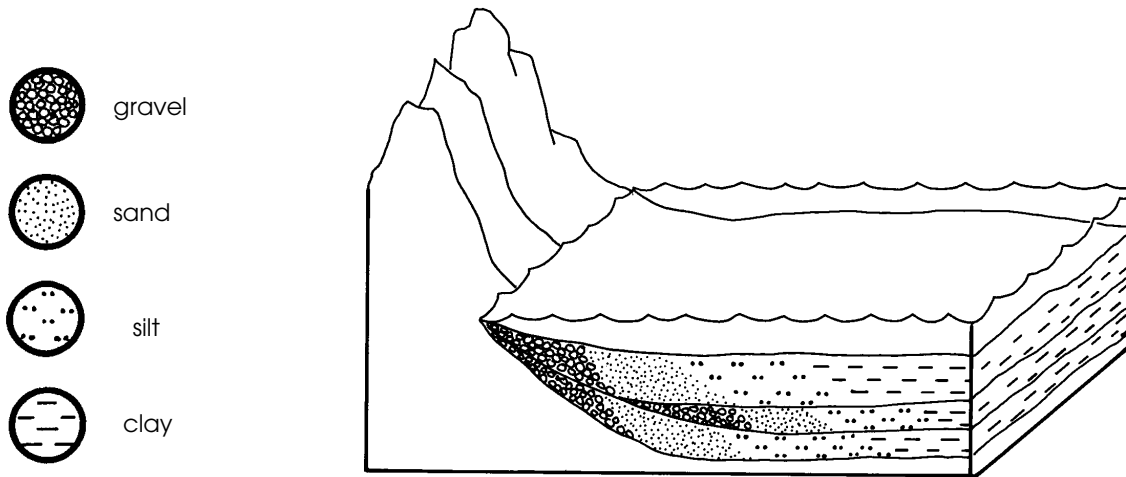

*The ocean shoreline retreated from its original position, then advanced to its present position.*

2. A geologist made a geological map of sediments, which is shown below. How does the average grain size change from west to east: does it increase or decrease? Where were the shallow and the deep parts of the sea that once covered this area?

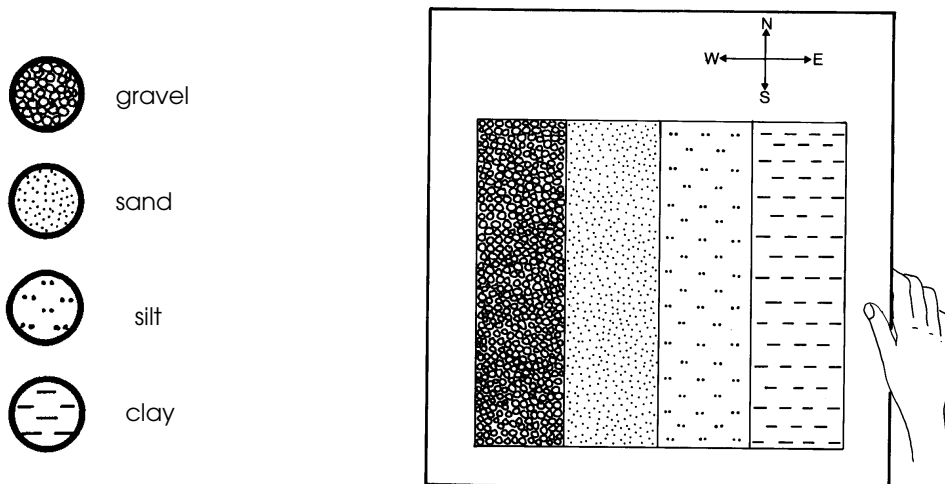

*The average sediment size decreases as you move from east to west. The shallow parts of the ocean overlay the gravel and sand: this was the "seashore". The silt and clay were overlain by a deeper part of the ocean.*



3. "Quigley Engineering Co. has dug a large, square, room-shaped block out of the bottom of a lake for engineering purposes. Assuming that sediments will be deposited onto the lake bottom, draw what geologists would see in the rock record three million years from now.

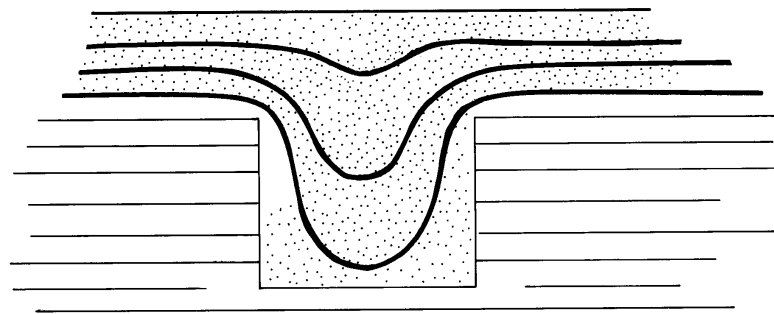
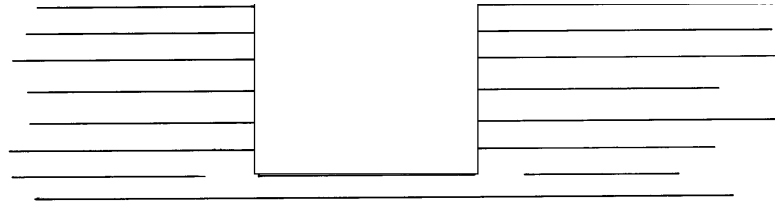

*If sediment continues to be deposited on the lake bottom after the block has been excavated, sediments will gradually fill in the excavated hole in the pattern shown below. This would smooth the contours of the lake bottom, and eventually hide the old quarry from view.*

### 3.1.4 ROAD LOG - BARRIER LAKE TO RIBBON CREEK

- 79.2 Here's a sixty-four dollar word to impress all your friends with - "Uniformitarianism". It means that processes that occurred in the past, such as rock-forming, are also occurring today. Based on this, what might eventually happen - after millions of years - to the sediments that are now being deposited at Barrier Lake?

*The sediments might eventually become sedimentary rock.*

- 79.5 Another possible name for a road cut would be "a slice through time". Why?

*Because the beds of rock that are exposed in a road cut were all formed at different times.*

- 80.4 From here you have an excellent view of the delta that is forming in Barrier Lake, as discussed in Stop #1.

Is the river a high-energy or a low-energy environment compared to the lake? Which would you expect to find deposited in the river: sand, or gravel? Why? Draw an arrow pointing to where the different sediment types might be deposited.

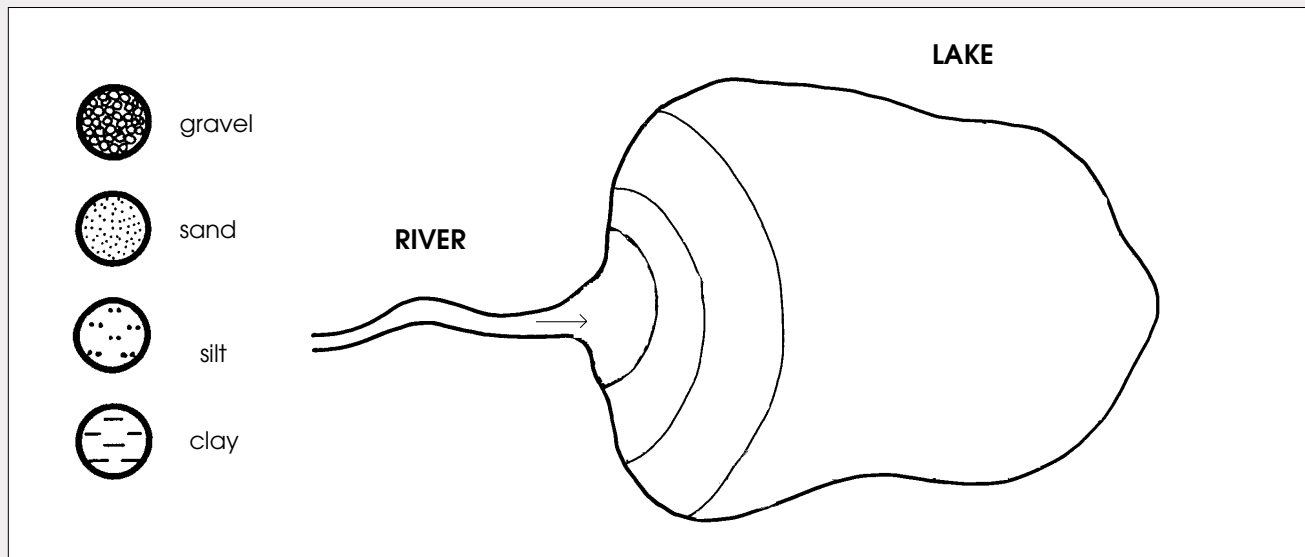

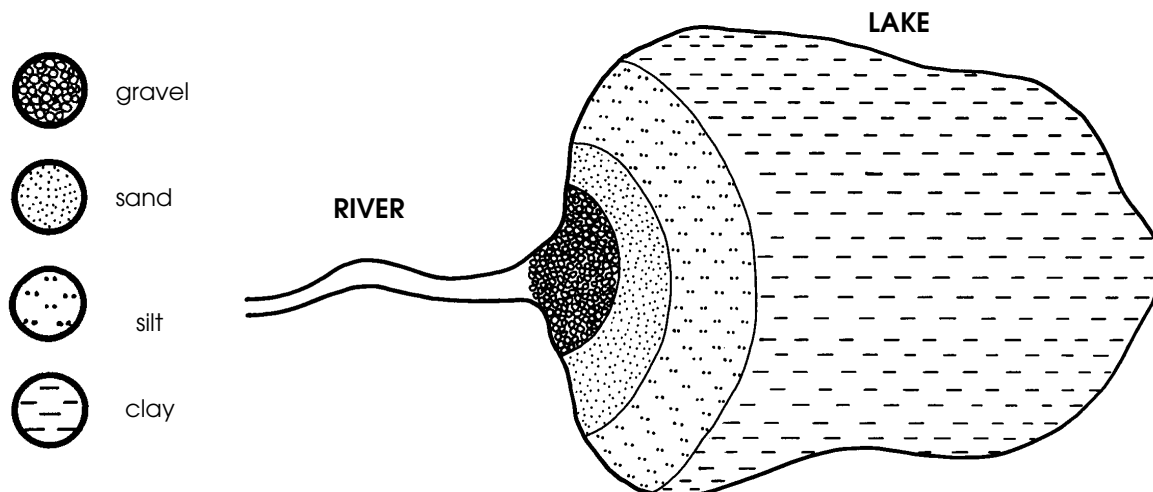

*The river is a high-energy environment; only the gravel would be heavy enough to be deposited here. The more finer-grained the sediment is, the farther it is deposited from the river mouth.*

90.5 Roadside interpretive sign for Nakiska Ski area - STOP the bus in the roadside vehicle space provided.

To the left of the ski hills on Mount Allan you can see the scar left by the reclaimed Mount Allan coal mine. In the 1940's this strip coal mine was opened on the east slope of the mountain. Due to a number of conditions, this mine proved not to be economically feasible and the operation closed in 1952. The coal found at this location was formed during the Cretaceous era, when swamp forests thrived in this area.

91.5 Turn off to Stop #2: Ribbon Creek parking lot.

93.3 Ribbon Creek parking lot.

## 3.2 STOP #2: FORMATION OF ROCKS

### 3.2.1 BACKGROUND INFORMATION

After being buried for millions of years, the layers of sediment begin to change. Pressure from the weight of billions of tonnes of sediment produces heat, which causes chemical change. As a result, the sediments became rock. In addition, as the sediments are buried deeper and deeper, they were also subject to high temperatures radiating from the earth's molten core. This heat and pressure causes the sediment grains to cement together, forming sedimentary rock. The process of loose sediments turning to stone is called **lithification**, and is one of the steps of the rock cycle.

Different kinds of sedimentary rock are formed, depending on the type of sediment. For example, sand becomes sandstone, silt becomes siltstone, and the clay becomes claystone or shale. The thick beds of calcite-rich sediment, made from the shells and skeletons of marine organisms, eventually becomes limestone, which is the most widespread sedimentary rock in the world.

#### Notes:

1. Calcite-rich sediments are a different type of sediment from those considered in Stop #1. Gravel, sand, silt, and clay are formed from the erosion of rock; sediments that contain calcite are only formed on the bottom of warm marine seas, and eventually form limestone.
- 2) Two other major rock types are found in the world. These are igneous rocks, which are formed from cooled magma, and metamorphic rocks, rocks that have been "cooked" at extremely high temperatures. These rock types are very rare in Kananaskis Country, and have usually been transported by glaciers to their present location.

### 3.2.2 ACTIVITIES

1. *For the "Rolling Stone Game", ask five or six pairs of the stronger students to stand in a row. These students are the "river". Have the rest of the class stand in a group at one end of the row; this second group is the "mountain". The teacher should stand at the other end, at the "ocean". The teacher should place some garbage bags or a tarpaulin on the ground beside him/her in the area of the ocean for the students to kneel on..*
2. *Explain to the class that they will be representing a mountain that is being eroded; the eroded sediment will be carried to the ocean, and the surface of the garbage bags will represent the ocean.*

- The "river" will carry the particles of sediment (i.e. individual students) down-river. To do this, the students will learn the seat carry. Have each of them extend their right arm above their heads, and then clasp their right wrist with their left hand. Lowering their arms, they then grab onto their partner's left wrist with their right hand - as does the partner - to form a stable square that the "river sediment" will sit on while being carried down to the sea (see figure).

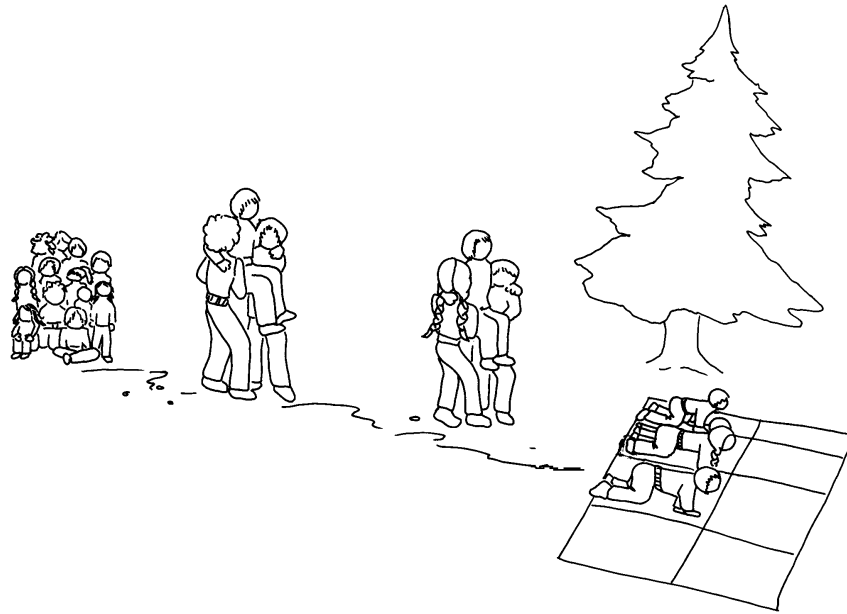

### *Class Activity and Pyramid of Students*

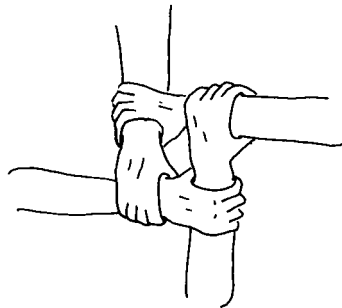

### *Hands for Seat Sit*

- Have each river pair carry a student (representing sediment from the mountain) to the garbage bags, and ask that student to kneel down on their hands and knees. Another student is then carried and placed beside the first student in the same manner, also kneeling. This process continues until there are enough people to form the bottom layer of a pyramid. The rest of the class is then passed down and arranged in a pyramid shape, as illustrated above.

## Discussion

1. What happened to the people below as more people were added to the top of the pyramid?

*Point out that as more people (sediments) were brought down the river and added to the pyramid, more weight was felt by the people below. This is analogous to the increase in pressure which cause sediments to turn to stone.*

*Ask the students what kind of pressures would cause sediments to turn into rock - they should realize that the pressure exerted by overlying sediments is indeed enormous.*

2. Name other important ingredients (missing from this activity) that are needed before sediment can turn into stone?

*One factor missing in this activity is heat. Heat is increased not only by the insulating effect of the overlying sediments, but also by their pressure. To illustrate how pressure produces heat, pump vigorously with a bicycle pump. Ask a student to feel the end of the pump (it should feel warm).*

## **ACTIVITY - ROCK IDENTIFICATION**

1. Each sedimentary rock has features which allow us to identify it and to discover what its origin is. **Use *The Sensory Guide to Rock Identification*** (next page) to help you identify three different rocks that you find on the ground in the area around Ribbon Creek. In the space below write their names, where you found them, and the kind of environment that they were formed in. Remember to return the rocks once you have identified them.

	<u>Rock Name</u>	<u>Location Found</u>	<u>Where the Sediments were Formed</u>
a)	<i>sandstone</i>	<i>along creek bank</i>	<i>near a beach</i>
b)			
c)			
d)			

Why is it that we can find several different rock types in the area of Ribbon Creek?

*The creek cuts across beds of different rock types along its course, and has transported these different rocks to this location.*

# SENSORY GUIDE TO IDENTIFYING THE ROCKS OF KANANASKIS COUNTRY

Begin Here!

**Break the Rock**

(put the rock inside a sock and break it with a hammer)



**Does the rock have layering and rounded grains, OR does it have sparkling crystals?**

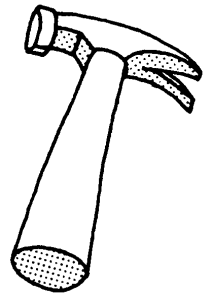

Layering and rounded grains

can't decide

Sparkling crystals



1. Are the grains larger than sand-sized?

2. Smell the freshly-broken surface: does it smell like rotten eggs?

No

Yes



**CONGLOMERATE**

Rub the rock against your teeth.  
Does it feel...

Like a jackhammer?

Gritty?

Smooth?



Can you see individual grains clearly?

Are the individual grains too small to be seen?

yes

no

yes

yes

**SANDSTONE**

**SILTSTONE**

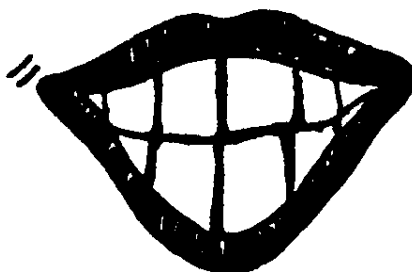

Do you get a "mud" when you wet the weathered surface?

**SHALE OR SILTSTONE**

Yes

No



Add HCl to the rock, and then look and listen. What fizzes?



The rock doesn't fizz.

Go to 1.

Only the fresh surfaces (not the weathered).

Both fresh and weathered surfaces.

**DOLOMITE**

**LIMESTONE**

### 3.2.3 CHALLENGE QUESTIONS

- Match the rock type with the type of sediment that it is formed from.

<u>Sediment</u>	<u>Rock Type</u>
silt	conglomerate
gravel	limestone
sand	shale
clay	sandstone
lime mud	siltstone

- When you add HCl to some rocks they fizz, due to a reaction with the calcite in the rock. What do you think would happen to a mountain of limestone in an area with an acid rain problem?

*Limestone is composed of calcium carbonate (calcite;  $\text{CaCO}_3$ ). The acid would react with the calcite and slowly dissolve it. (Caves are formed in limestone formations by this dissolving process). In fact, rain water is always slightly acidic, thus this process occurs (although at a slower rate) even in areas where there is no man-created acid rain problem.*

- Some sandstones “fizz” when acid is applied to them, even though the sand **grains** are not made of calcium carbonate. Why might this happen?

*The sand grains are held together by a cement that can be composed of hematite, silica, or calcite. In the latter case, the sandstone will fizz when acid is applied to it.*

- Do you think limestone could help solve the problem of acid indigestion? Hint: find out what *Tums* and *Rolaids* are made of.

*Both Tums and Rolaids are composed mainly of calcite,  $\text{CaCO}_3$ . The acid in your stomach could therefore be neutralized by contact with some powdered form of calcite, which forms the main mineral in limestone.*

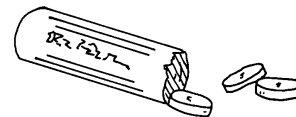

- Rivers and lakes in the foothills and mountains of Alberta tend to be less acidic than those in Ontario and Quebec, for two reasons. The first reason is that we receive less acid rain here than in Eastern Canada. What do you think the other reason is? (Hint: some of our mountains are limestone).

*The mountains - and the mountain-derived soils that lie in the valleys - tend to neutralize the acid in the rainwater that falls in this area. By the time the water reaches a lake, it is no longer acidic and has little or no detrimental impact on the lake system..*



6. The diagram below, entitled *Rock Cycle*, is incomplete. More arrows could be added than just the five shown here. Draw an arrow between two of the bolded words and describe the process that you think has to occur. There are several possibilities: for example, can a sedimentary rock become a sediment? (Yes, it can). What processes would have to occur? Write them in, and then repeat the procedure for a second arrow.

**THE ROCK CYCLE**

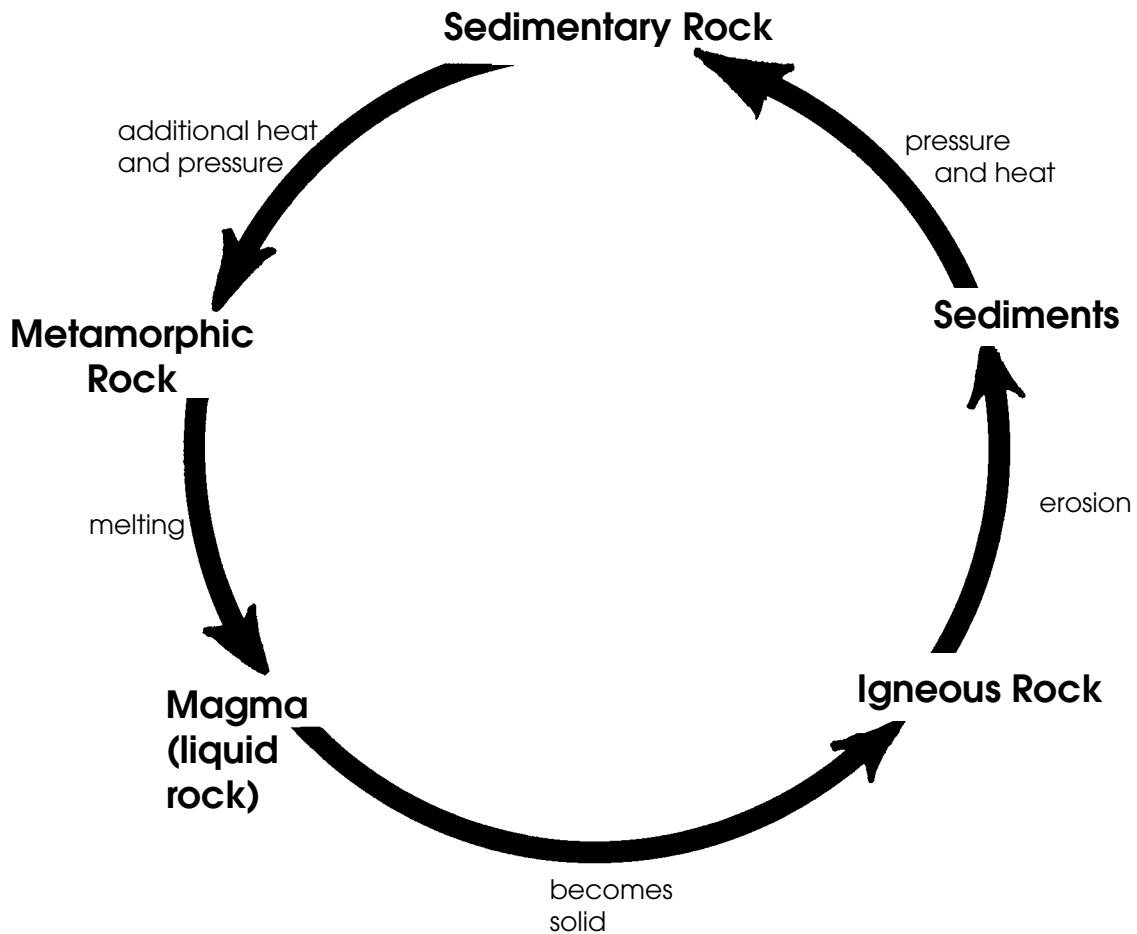

**THE ROCK CYCLE**  
*teacher's copy*

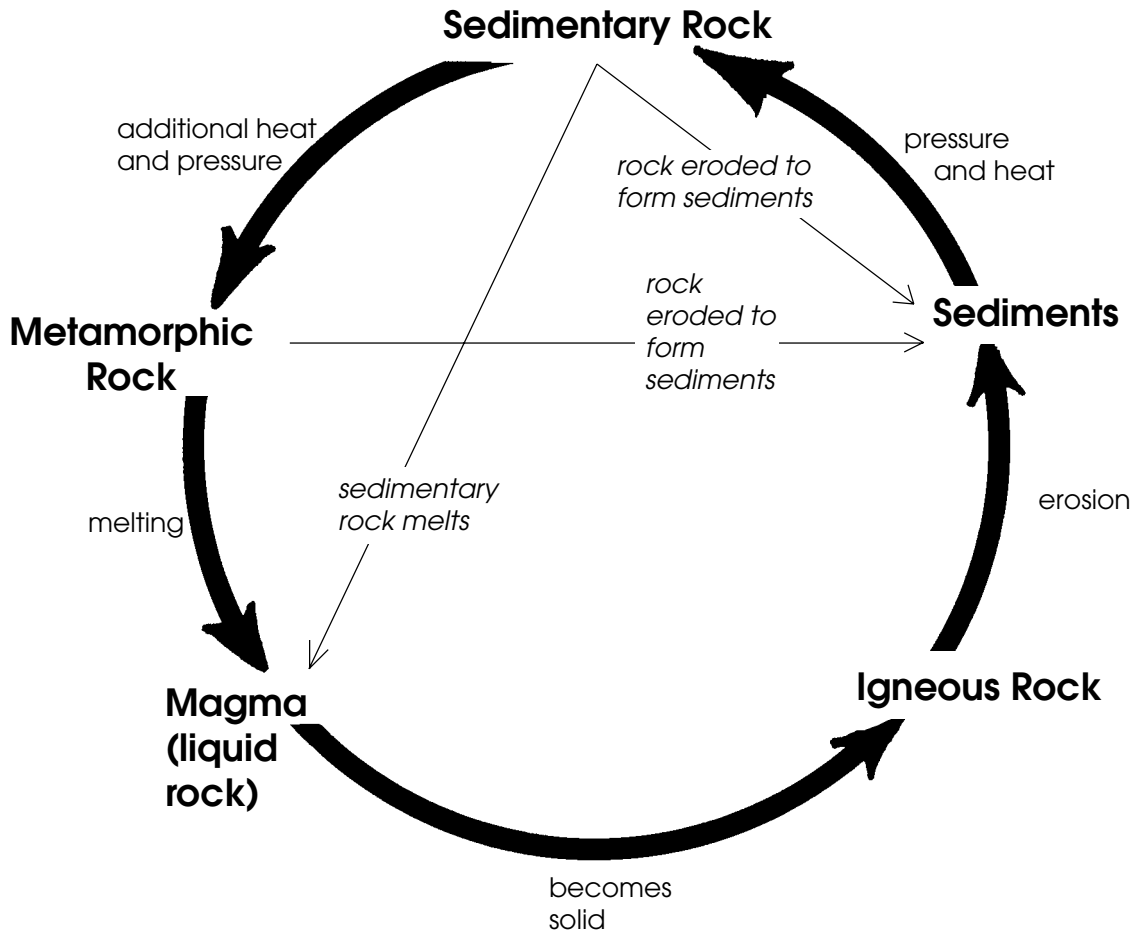

### 3.2.4 ROAD LOG - RIBBON CREEK TO GALATEA PARKING LOT

- 96.4 (View of Kananaskis Village to the west)  
The terrace-like formation that the Kananaskis Village is built on was deposited by a glacier, and is called glacial till. What do you think the glacial till is made up of?

*The brownish cliff-like formation is actually a lateral moraine, composed of glacial till that was deposited by the glacier that occupied this valley during the Ice Ages. It is composed of clay, sand, silt and gravel all mixed up together.*

- 97.4 (Mount Kidd to the west - right side of the bus)  
Like Mount Yamnuska, this is another “split-level” mountain: older rocks overlying younger rocks, separated by a fault. Keeping in mind the fact that limestones and dolomites are very hard rocks, while sandstones and shales are relatively soft rock, what type of rock do you think Mount Kidd’s steep cliffs are made of? What about the gentle slopes below? Label these two rock types on the diagram below, and label where you think the thrust fault is.

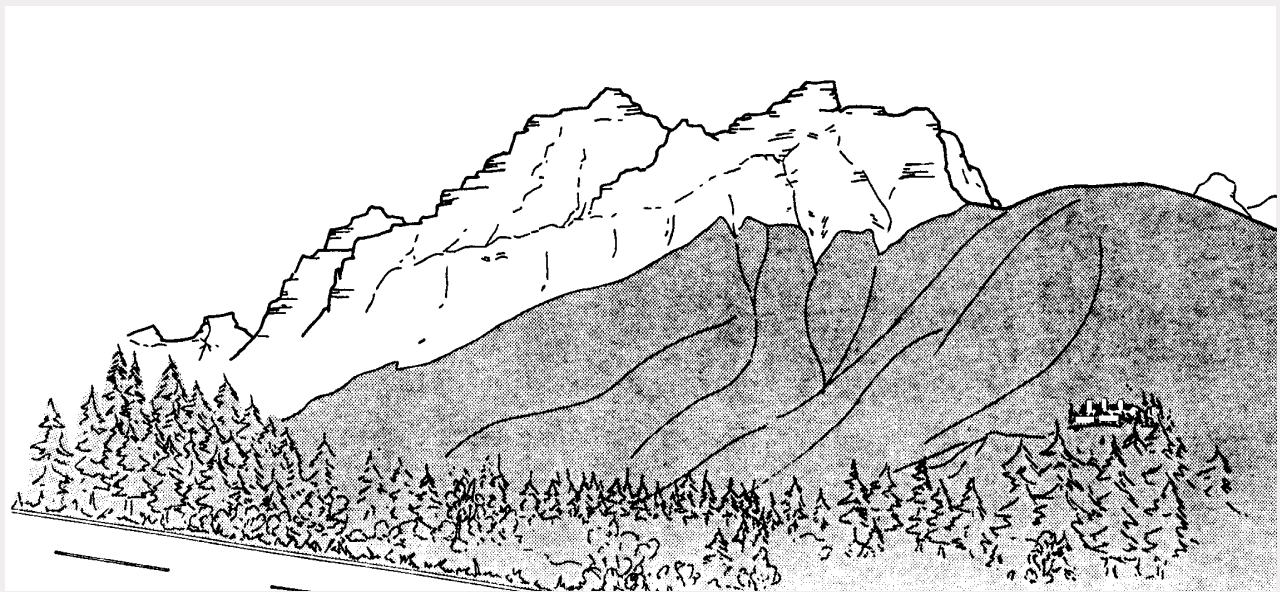

**Mount Kidd, looking south-west**

*The limestones and dolomites are the cliff-forming rocks, while the gentle, tree-covered slopes are underlain by sandstone and shale. The thrust fault is marked by the abrupt transition of the two rock types of rock (in the diagram, where the shaded area meets the plain area).*

- 105.4 Turn off to Stop #3 - Galatea parking lot.  
105.6 Galatea parking Lot

## 3.3 STOP #3: MOUNTAIN BUILDING

### 3.3.1 BACKGROUND

#### Plate Tectonics

Have you ever played with balloons full of water (water bombs) in the summertime? Let's compare the earth to a water bomb. The earth is similar to a water bomb in that it has a liquid core (which is hot), and a cold, solid crust which sits on the core.

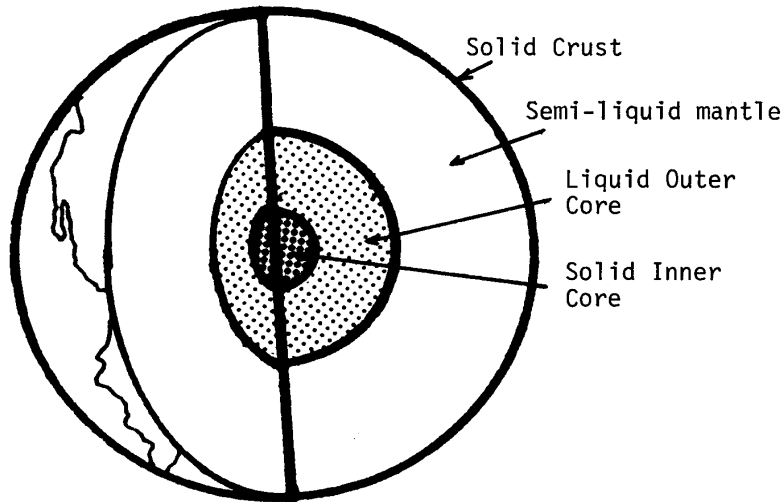

**Cross Section through the Earth**

The crust is not one smooth piece, like the skin of a water balloon; rather it is made of sections, or **plates**, that fit together like the pieces of a giant jigsaw puzzle. As you read these words these plates are sliding around on the surface of the earth's semi-liquid core at a very slow rate of only a few centimetres per year. Some of the earth's plates are slowly spreading apart from each other; others are being thrust underneath other plates as they approach one another; and still others are just sliding past each other. Figure 3-2 shows the names of these plates and their direction of movement. We live on the **North American Plate**. The theory of why plates form, disappear and change in shape and size is called **Plate Tectonics**.

#### Subduction

The North American plate and the Pacific plate to the west of it have been colliding very slowly for millions of years. As they collide, the thin Pacific plate is pushed down under the thicker North American plate, into the hot liquid mantle below. The active volcanos that are found in Washington state are caused by this process.

*Note to teacher: it might be instructive to tell your students that **both** the North American plate and the Pacific plate are moving as this subduction occurs. Too often, the continental plate is pictured as static, while only the oceanic plate is pictured as moving. In fact, they are both moving.*

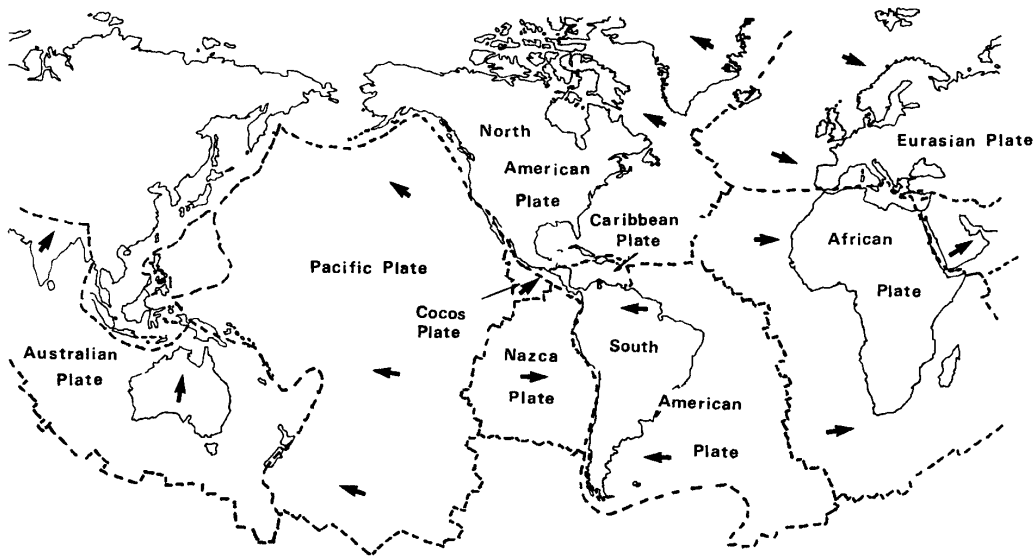

**The Earth's plates**

### Car Crash Analogy

The pattern of deformation of the Rockies is especially apparent when seen on a geological map: virtually all of the mountain ranges are aligned in an approximately north-south direction. It is as if the continent of North America were a parked car that had been hit by a moving car (i.e., the Pacific Plate); the crash caused a series of ridges, parallel to the impact front, to occur on the west side of the continent, forming the Rocky Mountains. The ridges were formed where rocks to the west were pushed along thrust faults, up and over the rocks to the east. (See the next page for a description of thrust faults).

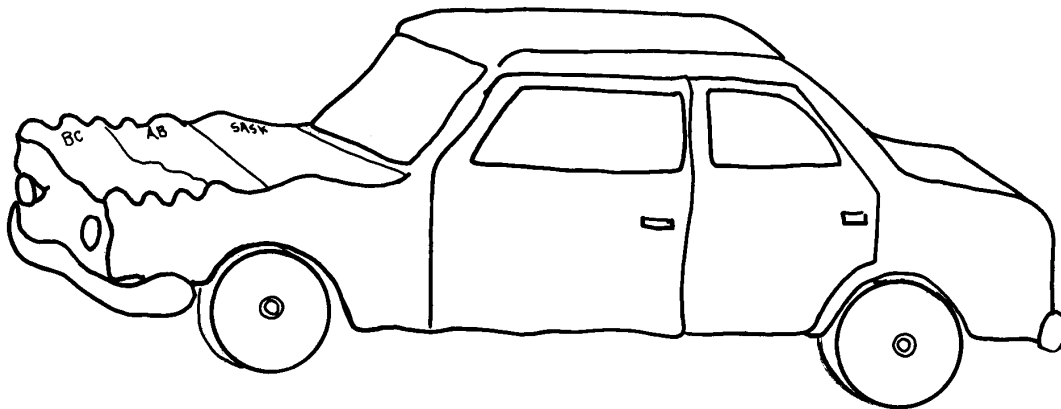

**The "North American Continent" car; note the crumpled hood!**

**Note to teacher:**

1. Both of the plates were moving when the collision occurred; however, from the point of view of an observer on the North American plate, only the oceanic plate appears to be moving.
2. The parallel ridges referred to in the car crash analogy can be illustrated by using either of the two maps referred to in Section 2.1 (the geological map of Alberta and the Lansat image).

As a result of the subduction that was going on, all of the sedimentary rocks in the area of the present Rocky Mountains felt compression forces, as if the two plates were pushing at them from opposite sides. This compressional force caused the sedimentary rocks to bend and break. The bends in these rock beds are called **folds**. Large cracks in the rock beds are called **faults**. Folds and faults can both be seen in Kananaskis Country.

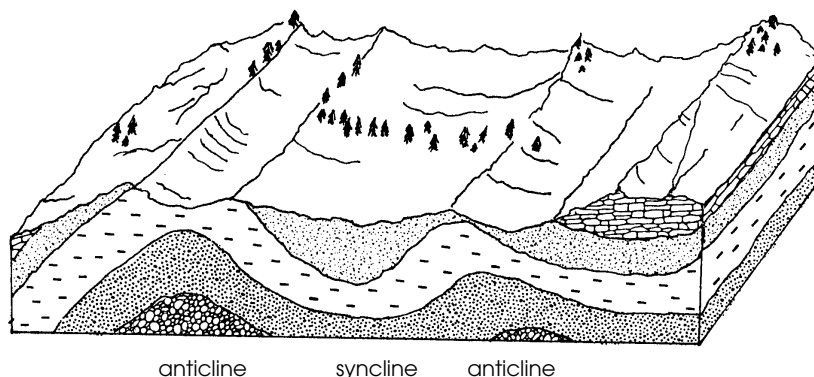

**Anticline and syncline folds**

Thrust faults are caused by compression being exerted on a layer of sedimentary rocks. A fracture line develops, and the rocks above the fault line or fracture line are "thrust" above the rocks that lie below the thrust line. The two figures below illustrate this occurrence.

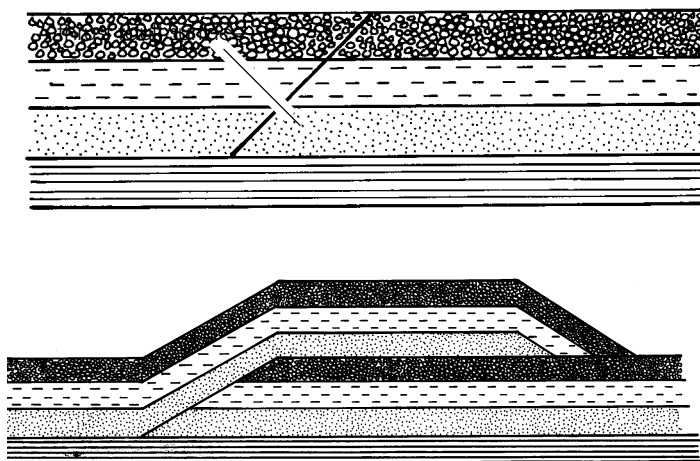

**Sedimentary rocks:  
before and after thrust fault**

## Isostatic Rebound

The forces resulting from the collision of the North American plate and the Pacific plate caused subduction to occur, as described earlier. Another effect of these huge compressive forces occurred further inland, along the boundary of Alberta and B.C: during the time these compression forces were active, the crust of the earth in this area was warped downwards, carrying the overlying rocks in the area downwards with it and creating a large depression in the earth's crust.

Let's return to the water balloon. Have you ever poked your finger into one? If you have, you might remember that, as you pressed your finger into the balloon, it felt as if the balloon were pushing back on your finger. This is because the water inside the balloon exerts a pressure on the skin of the balloon, and also on your finger when you press your finger into the balloon.

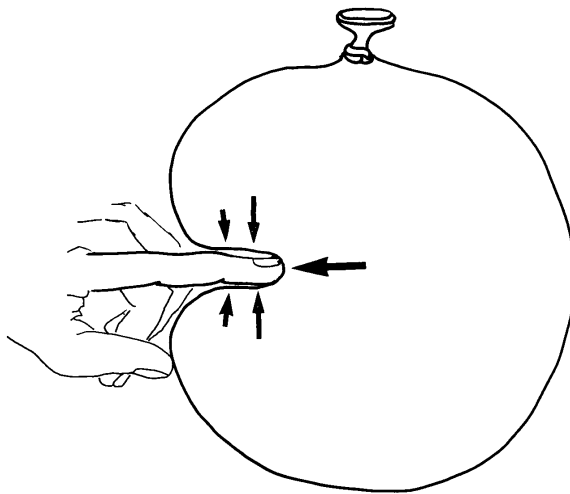

### **Pushing on a Water Bomb**

But what happens when your muscles in your finger get tired and you stop pushing into the side of the balloon? Your finger is pushed back to the surface of the balloon. The same thing happened to the earth's crust. Fifty million years ago, when the compressive forces ended, two things happened: the folding and faulting ended, and the earth's crust began to "bounce back" in the very same way as your finger is pushed back to the surface of the balloon. This "bouncing back" process is known as **isostatic rebound**. Even though the rebound process began 50 million years ago, it is **still happening - the Rocky Mountains are slowly being lifted up!** Why don't we feel as though we were in an elevator going up? Because the uplift occurs very slowly - at a rate that is measured in just a few millimetres per year.

Incidentally, you may have heard of isostatic rebound before if you have studied glaciation.

When continental glaciers covered North America with hundreds of metres of ice, their weight made the crust of the earth sink in much the same way. The melting of the ice resulted in the uprising of the crust over the period of hundreds of years through the process of isostatic rebound.

*NATURE OF SCIENCE: It is interesting to note that the story of the formation of the Rockies is incomplete: scientists don't have all the answers! For example, although geologists are sure that the mountains are still rising upwards from isostatic rebound, they don't know how fast. Also, it is still unclear to geologists **why** the process of isostatic rebound is occurring; was it because of the compressional forces acting on the sedimentary rocks, as described above, or was there some other mechanism?*

### **Boiling Soup Analogy**

How continental plates move can be demonstrated by heating soup or milk. As the hot liquid bubbles, a cooled "skin" begins to form on the surface, and soon creates a layer that is moved about by the hot liquid that circulates in a convection pattern beneath the surface. The pieces of skin act very much like the plates of the earth. The skin, in floating about on the surface of the liquid, tends to become wrinkled and distorted when it collides with other surface layers. These wrinkles are analogous to the mountain ranges that form when continental plates collide; the hot liquid underneath represents the earth's molten magma.

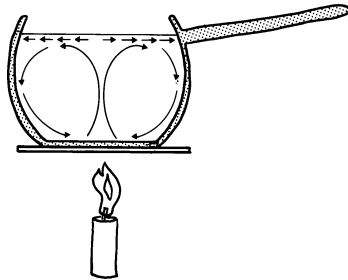

In addition, the skin in the middle of the pot tends to be spread apart by the uprising liquid in this area. This is also a good analogy to the earth's **rift zones**. Evidence of two plates' moving apart is found in the middle of the Atlantic Ocean, where an opening or **rift** is located. Uprising lava creates newly formed volcanic rock along this rift.



### 3.3.2 ACTIVITIES

The earlier stops explored sediment accumulation and the creation of rocks; now it is time to look at how layers of rocks are deformed into the many different shapes and forms that we see today.

1. The diagram below shows sedimentary rock that has been bent into folds. A fold is simply a bend in what was once a flat-lying bed caused by forces in the earth.

Folds have two basic shapes. When the rock is bent upwards in the middle the fold is called an **anticline**; when the rock is bent downwards in the middle the fold is called a **syncline**. Label the synclines and anticlines that appear in the diagram below.

Anticlines and synclines

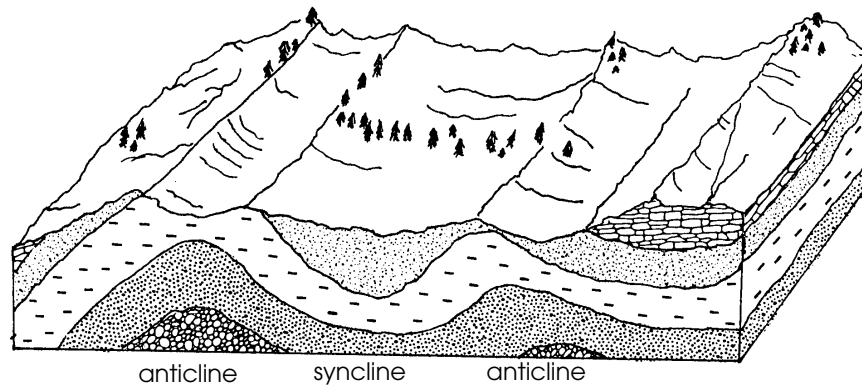

#### Folding Demonstration I

**Note to Teachers:** although this demonstration is best done using construction paper, it can also be done using a sheet of loose-leaf paper.

Ask for two volunteers. Holding the strip of construction paper horizontally in front of you, have the two students stand at your elbows. Tell the class that the paper represents a sedimentary bed, and that the volunteers represent compressional forces. Have the students push on both ends of the sheet. With a little manipulation, both a single fold (either an anticline or a syncline) and an anticline/syncline pair can be created.

forming a single anticline



forming a syncline/ anticline pair

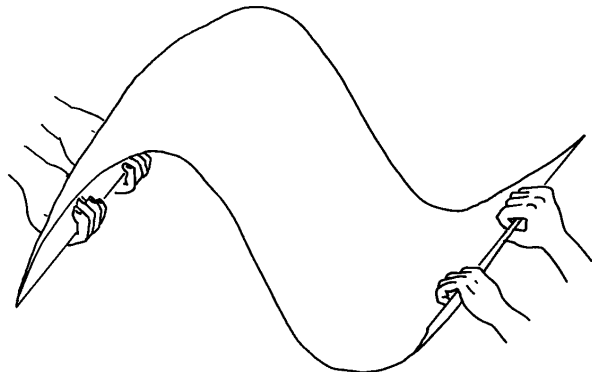

2. Look about you. In the rocks of one of the mountains the layers have been folded to form an anticline and a syncline. Label them on the diagram below.

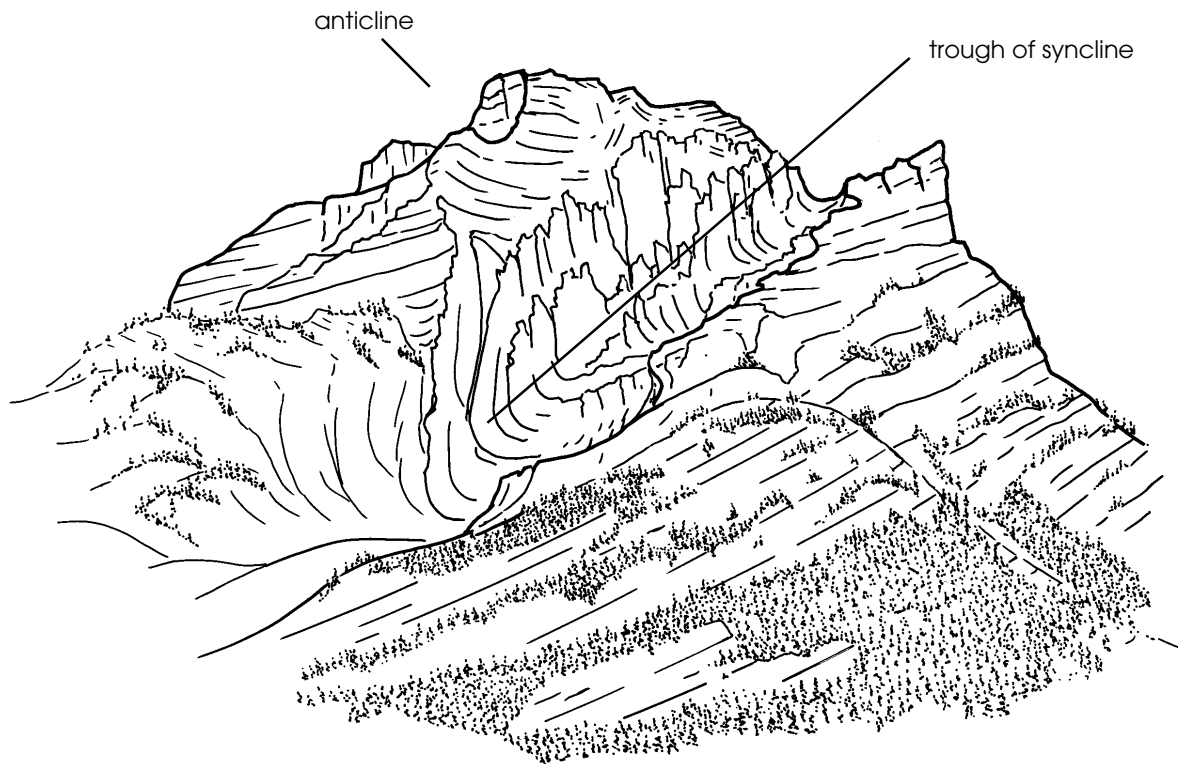

### Mount Kidd anticline and syncline

#### Folding Demonstration II

Give each student about 500 grams of modelling clay (about the size of a **large** snowball should suffice) and have them break it into two equal portions. Tell the students that they will first make a "sandstone" layer. Instruct them to use half of the clay to make a layer that is flat, thin, and square.

The next step is to make a similar layer - you will call this layer a siltstone. Place this layer on top of the sandstone layer to make two beds. To make the exercise more realistic, you might have the students add a few pinches of sand and silt (collected at the first stop) to the mixture; however, this would make the clay quite difficult to reuse. One possible alternative is to use two different colours of clay.

Ask the students to push the two ends of the layer together to simulate compressional stress. With patience, they will produce either one or two folds in their layered model.

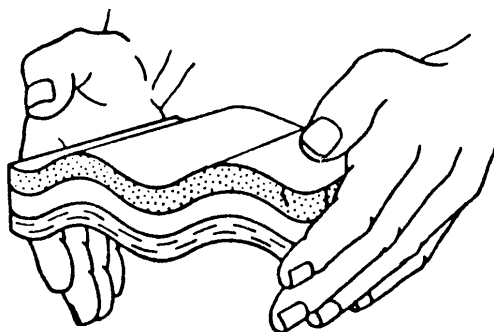

### Hands folding clay

*Note to teacher:* Instruct students to save their models for the next stop.

### Faulting Demonstration

When rock is very strong, yet brittle, it tends to fault rather than fold. Ask students to stand facing Mount Kidd (i.e. towards the north) and to put their fingertips together, with their elbows pointing at the horizon, to simulate a strong sedimentary bed. Ask the students to imagine that the palm of their hands are two separate bands of rock. Ask them which layer would be older; they should realize that the "palm" layer is older, having been deposited first.

Next, ask the students to push their hands together. They should allow their left hand to rise slightly, so that the fingertips lose contact with the fingertips of the right hand and the left hand is allowed to slide over the right hand.

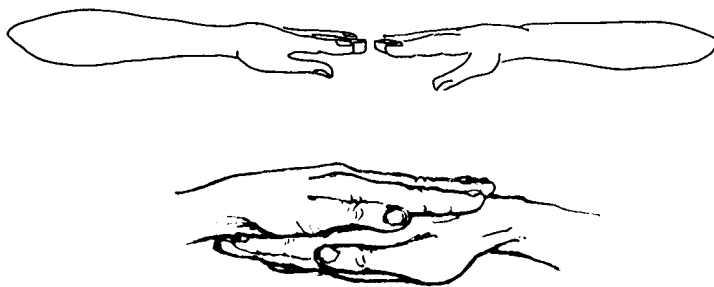

### thrust fault demonstration : pre- and post-fault

Students have created a thrust fault. A thrust fault is defined as a fault, or break in the rock, where the lower strata have been thrust over the upper strata. A thrust fault is characterized by having the fault plane at a low angle (less than 30 degrees from the horizontal bedding).

Continued pressure results in the left hand riding over the right hand; this is similar to what happened in the Rockies, with the more westerly sheets of sediments sliding up and on top of the eastern ones. Point out that now the bottom of the students' left hands are resting on the top of their right hands; this corresponds to older rock sitting on top of younger rock, a common phenomena that we have seen in Mount Kidd and Mount Yamnuska.

**ELECTIVE:**

Use a water-filled balloon to demonstrate the uplift that has raised the folded and faulted rock mass to its present elevation. Tell the students that the balloon represents the entire earth, and that the plastic balloon surface represents the crust of the earth. Have a student press his/her finger into the body of the balloon. Ask the student if they had to use some force to insert their finger; they should answer in the affirmative. Then tell the students that this same finger force is similar to the forces that were felt by the crust when the compression forces were causing the folding and faulting; therefore, the crust of the earth sunk underneath the Rockies.

Later (around 50 million years ago) all of the forces stopped. Ask the volunteer student (whose finger might be getting tired by now) to stop pushing down into the balloon. Their finger should move out to the surface of the balloon. The same thing happened in this area. Once the folding and faulting stopped, the crust of the earth began to rise back up: this is called isostatic rebound, and marked the beginning of the rock mass uprising that is still occurring today.

### 3.3.3 CHALLENGE QUESTIONS

1. Using what you know about the appearance of thrust faults, explain how mountain ranges can be compared to shingles on a roof.

*Sheets of thrust-faulted rock layers pile or overlap on top of each other as continents collide, much like the overlapping of roof shingles.*

2. Indicate on the diagram below the direction you think the rock layers on either side of the Mount Rundle thrust fault moved.

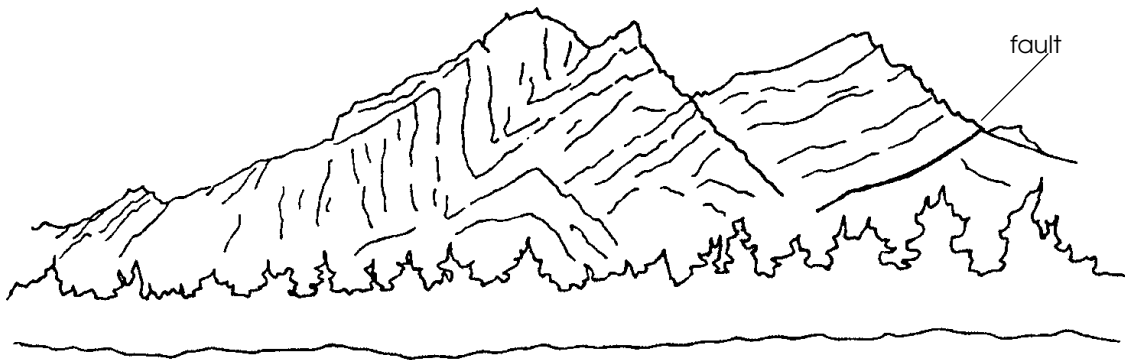

**View of Mount Kidd, looking north**

3. What would happen to a trampoline mat if, over several hours, you continually piled rocks onto it?

*The mat would be forced lower as the weight of rocks on it increased.*

4. During the formation of the Rocky Mountains, the thrust fault activity caused a very thick layer of rocks to be deposited. Remembering what happened to the mat, what do you think this weight did to the earth's crust?

*The crust subsided under the weight. (It also is believed that the crust subsided due to compression pressures caused by the collision of the continental plates).*

5. When the rocks are removed from the trampoline mat, it will spring up again. Rock material is presently being removed from the Rockies by erosion. What effect do you think this would have on the earth's crust?

*Isostatic rebound results in the uprising of the earth's crust due to a decreased weight upon it. (The cessation of mountain building forces also allows isostatic rebound to occur).*

### 3.3.4 ROAD LOG: GALATEA TO LOWER LAKE DAY USE AREA

- 106.7 A very large-scale “slice of time” can be seen to your right. Here, the slicing was not caused by a road crew, but by a much larger force, which you’ll find out about at your last field study stop.
- 109.0 Opal Day Use Area.
- 115.2 Fortress Junction.  
What might have caused the large “bowl-like” formation in the mountains to your right? Hint: The “Great White Chisel” has left yet another clue to its existence here..

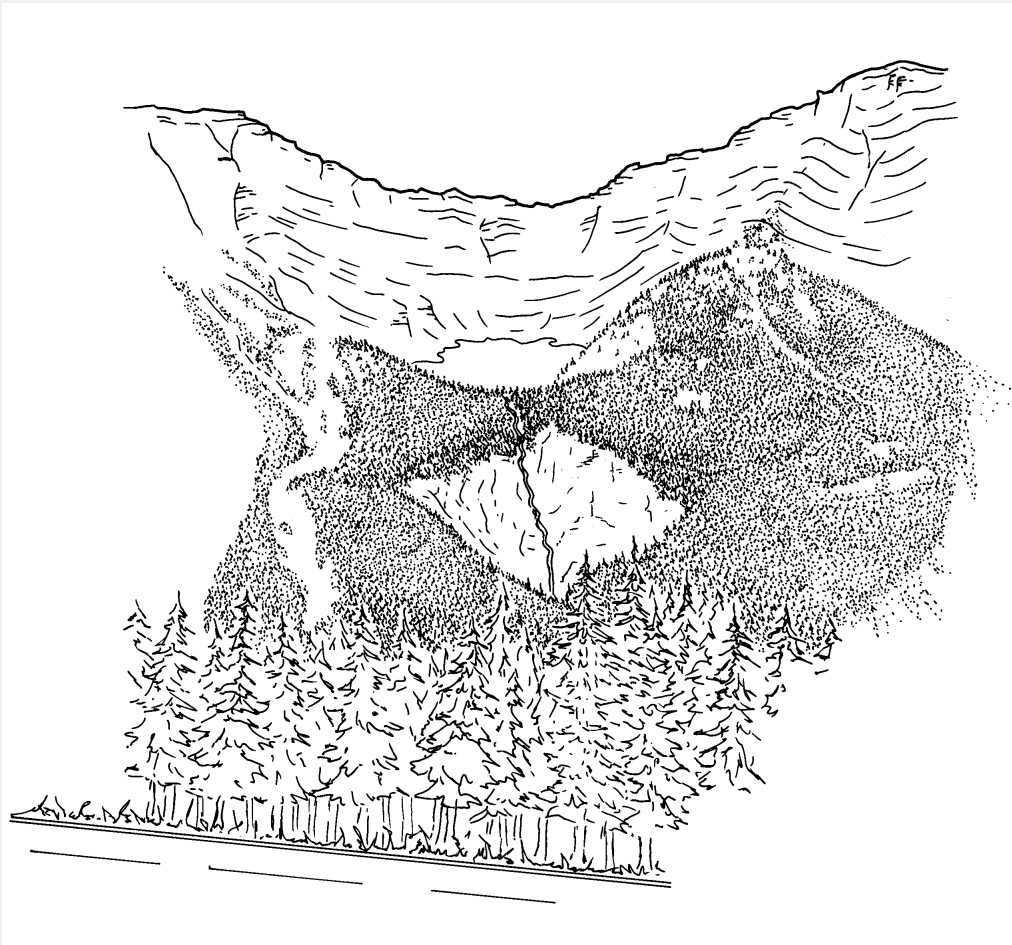

**Cirque at Fortress Junction - looking west**

*The bowl is called a cirque. It was formed by a glacier that sat in the bottom of the bowl and “ate into” the sides of the mountain, making the cirque larger over time.*

- 118.7 Grizzly Creek marks the northern boundary of Peter Lougheed Provincial Park.
- 119.4 What would have created the bare patches that extend downwards from the top of the mountain to your right? Hint: this occurrence happens most often in

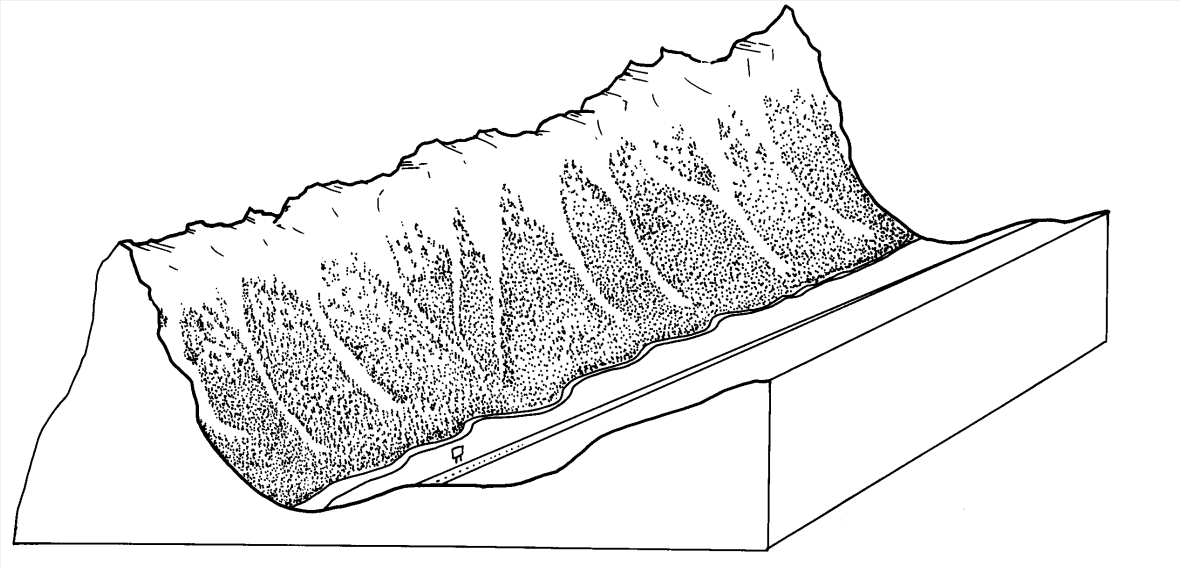

winter and early spring...

*These treeless patches are known as avalanche paths, or avalanche chutes. Avalanches "bulldoze" away any tall trees or shrubs that might begin to grow on the chutes, keeping the area bare of trees, and allowing the growth of grasses, flowers, and shrubs.*

120.7-122.2 (Elective stop at the crest of the hill)

At first glance, the rock slabs to your left may seem rather plain. But upon closer examination you will see fossilized ripple marks. Approximately 200 million years ago, these ripple marks were formed in sand and silt by ocean currents. Geologists speculate that at the time that these were forming, a large coastline existed in this area, and the first crocodiles, lizards and turtles were beginning to swim the earth's waters.

Why is this ancient sea bottom now standing on its side?

*Compressive forces have tilted, deformed, and upthrust many of the rocks in Kananaskis Country.*

- 125.0 Turn right just after the parking lot for the King Creek trail - **do not** continue down Highway 40 towards Highwood Pass.
- 134.6 Turn-off to the right - Lower Lakes Day Use Area.
- 135.8 Lower Lakes Day Use Area.

## 3.4 STOP #4: EROSION

### 3.4.1 BACKGROUND

First, sediments were buried beneath thousands of tonnes of other sediment; next, huge pressures and heat transformed these sediments into layers of rock; then, tremendous forces bent, twisted, crumpled and broke the rock layers. What other forces could the Rocky Mountains possibly be subjected to?

# DESTRUCTION!

From the moment the Rockies first started to cast shadows on the plains, they have been attacked by natural processes that seem bent on destroying the mountains. **Weathering** breaks the rocks down, and **erosion** carries the fragments to new locations. Together, these processes began to relocate the sediments that took millions and millions of years to become mountains.

On this field study, look for these weathering and erosional processes:

#### CHEMICAL WEATHERING

Another name for chemical weathering could be "rock dissolving". When rain falls it mixes with the carbon dioxide in the air to form a mild acid called **carbonic acid**. When this mildly acidic rainwater comes into contact with rock, some substances in the rock are dissolved by the water. The substance that dissolves most in acid is a mineral called calcite, which has the chemical formula  $\text{CaCO}_3$ . Where there is a lot of calcite in the rock, the whole rock is slowly broken down by what appears to be the most gentle of substances - water.

#### MECHANICAL WEATHERING

Any physical process that helps to break down rock is called **mechanical weathering**. One of the main forms of mechanical weathering is called **frost shattering**. This happens when water seeps into the cracks of a rock and expands upon freezing. The ice acts like a small but powerful wedge, and can split a rock into smaller pieces. The pressure from growing tree roots can also act as a wedge. Changes in a rock's temperature (i.e., heating by sunshine, then cooling by rain or snow) causes cracks to grow as the rock expands or contracts. This is also a form of mechanical weathering.

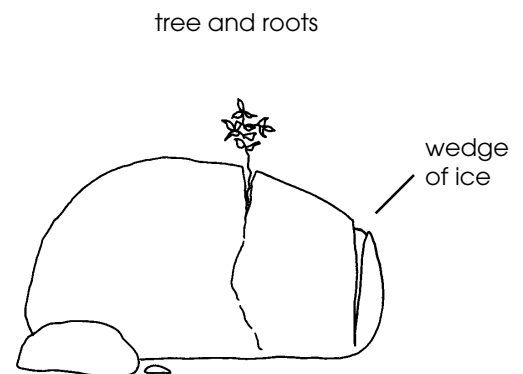

Wedges formed by ice and roots



## WATER EROSION

In its various forms, water carries most of the rock back to the sea. Rivers and creeks cut into mountainsides, creating deep V-shaped valleys like the ones seen in the mountains surrounding the Upper Kananaskis Lake. Rain pounds into the sides of mountains, carrying away loosened sediment and rock as it runs down the mountainside.

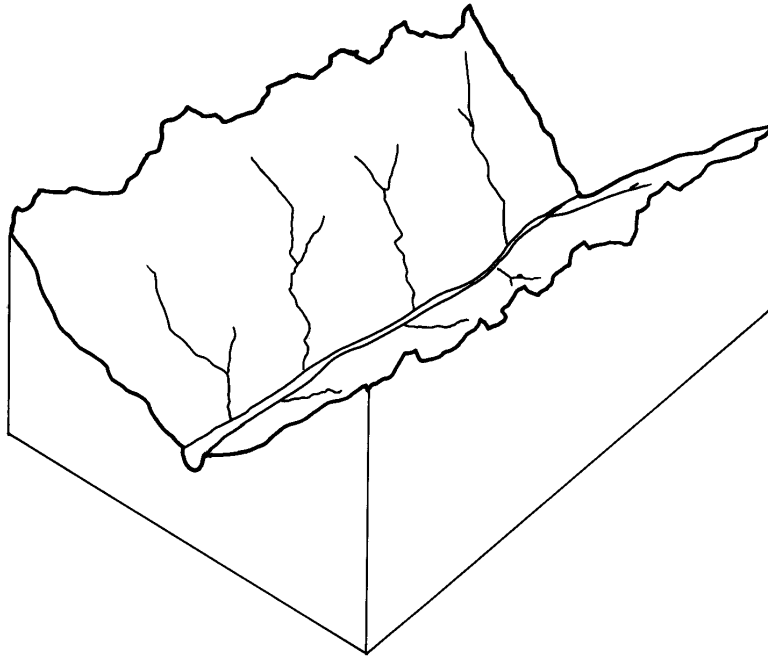

**Water Erosion**

## WIND EROSION

As wind blows, it can pick up hard grains of rock sediment and blow them into exposed rock outcroppings. Like a sandblaster, these hard grains can wear away softer types of rock.

## GLACIAL EROSION

The most important erosional force in the Rockies was - and in some locations, still is - ice in the form of glaciers. For almost two million years this major erosional force visited and revisited North America. In fact, ice once covered areas in Kananaskis Country to heights of 600 to 1000 metres!

Where conditions are cold enough to prevent snowfalls from melting during the summers, the snow begins to accumulate. As the weight of the overlying snows increases, the snow compacts and eventually turns into massive ice sheets. The ice sheets are called **glaciers**, and are so heavy that they tend to flow downhill. As they flow, they picked up large rock fragments which act as grinding tools to carve and scrape the rock surface beneath them.

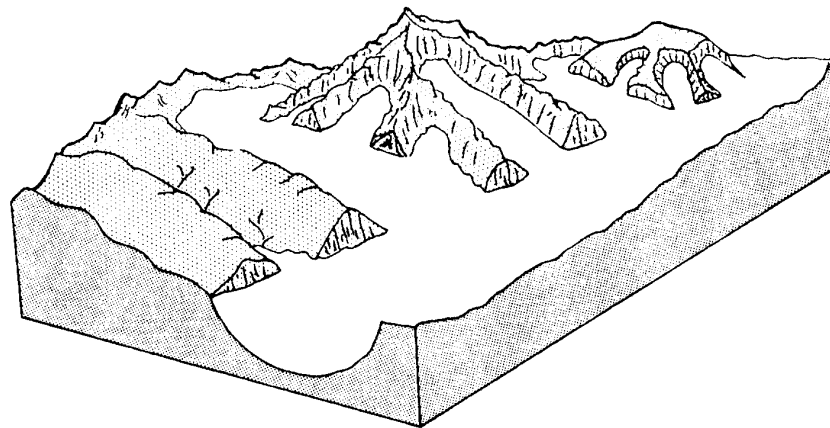

### Glaciated Landscape

Glaciers are still present in some areas of Kananaskis Country, and are seen at Stop #4 of the field study. But they were much larger and more abundant during the last ice age when, working like giant pieces of sandpaper, the glaciers reshaped the “Blocky Mountains” into the peaks and scenic valleys of the “Rocky Mountains” that we see today.

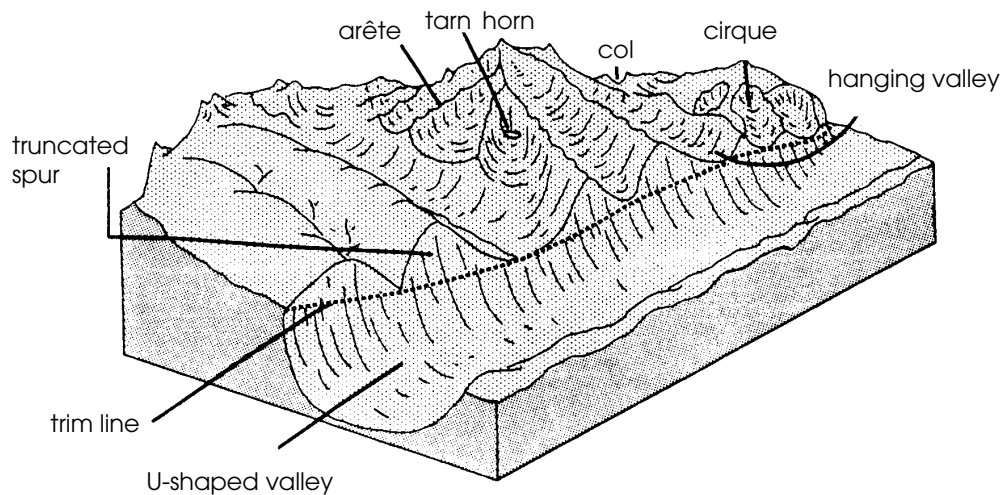

### Glaciated Landscape features

#### CONCLUSION

We have now come full circle in the story of the Rocky Mountains, from their birth in the sea to their eventual return.

By deciphering the rock records which reveal the many forces affecting the earth, we can gain an understanding of how the Earth has always been in a state of change, and of how the earth's "building materials" are constantly being used over and over again, resulting in the birth and death of whole mountain ranges. What happened to the Earth's crust in the past is happening now, and will probably happen long after humans have made his final mark on the planet.

### 3.4.2 ACTIVITIES

#### A) WATER EROSION

The main erosional force in Kananaskis Country these days is... water erosion.

1. Fill a transparent plastic cup with water from Boulton Creek. Try to get the best water sample you can find. Be careful not to disturb the stream bottom and stir up the bottom sediment.
2. Hold the sample of water up to the light and examine the water closely. Do you see any particles floating in the water? If you see nothing, try swirling the water slightly in the cup and try again. What do you see floating in the water?

*Most students should be able to see at least a few particles swirling in the water. Most of these are silt-sized particles that were being transported by the creek.*

*Tell the students that, despite the apparently low mass of sediment that is seen in these water samples, Boulton Creek can actually transport up to 100 kg of material per day, while large rivers such as the Bow River can transport enough sediment to fill 150 half ton trucks in one day!*

3. Carefully pour several cups of water over the clay model you prepared at the last stop.
  - a) What do you notice about the surface of the model after the water has passed over it?
  - b) What do you think would happen if a stream of water were allowed to pass over your model continuously?

*a) The water is slowly eroding the clay surface of the model.*

*b) Given enough time, the clay model would be completely eroded away.*

4. Take a closer look at Boulton Creek.
  - a) Where might the river sediment have come from?

*Either from the river bank or from the mountain rocks farther upstream.*

- b) Predict the effect the sediment load might have on the creek bank and bottom. (Hint: sand suspended in the water has the same effect on the river bank and bottom as sandpaper has on a piece of wood).

*A stream's sediment load is responsible for much of the erosion of the banks and bottom.*

- c) What would happen to the sediment carried by a river if the river were dammed?

*When the river waters arrive at the reservoir, the sediment would sink to the river bottom, since the water would no longer have the energy to transport it. Siltation of the area behind dams is a serious problem, effectively shortening the lifespan of a dam by decreasing the volume of water that can be stored behind it.*

### Cookie Activity

5. If you have wafered cookies, unwrap them - but no bites yet. Observe that the cookie is composed of different layers of edible materials. Choose a surface that shows this cookie layering (e.g., the edge of the cookie) and lick this surface fifty times. What do you observe about the erosion of the surface?

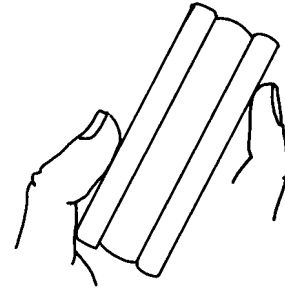

**layered cookie**

*If the wafer and the filling are sufficiently different in hardness, the students should notice that the filling has been eroded away faster than the wafer.*

*This differential erosion rate was responsible for the long, straight valley that you drove down when you entered Peter Lougheed Provincial Park on Highway 40. The Kananaskis River lies on top of easily eroded shale; to the east and west are mountain ranges that are more resistant to erosion. An analogy can be made by comparing the cookie filling to the more easily erodible shale, and the more resistant mountain ranges to the cookie wafer.*

### **B) GLACIAL EROSION**

6. The diagram on the following page is a panorama of the scene that you see in front of you from the Lower Lakes Day Use Area. Arrows on this diagram point to various different landforms. Choose from among the following list of landform names to label your diagram.

horn	arête	cirque	glacier
U-shaped valley	anticline	syncline	

*An answer key to Question #2 is provided by a figure on the following page.*

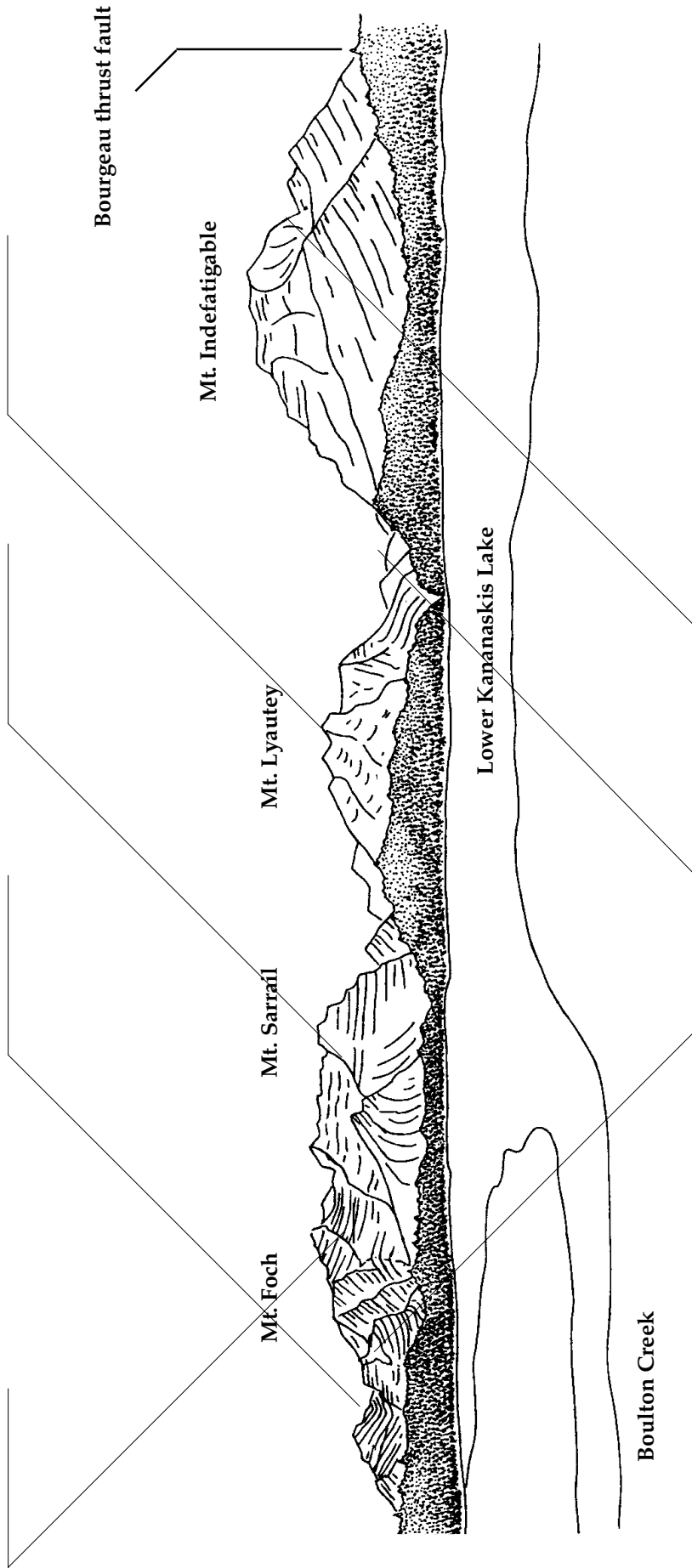

**Notes:**

The Borgeau thrust fault separates Devonian Rock (370 million years old) from Jurassic rock (104 million years old). A difference of 200 million years is seen along the thrust fault line.

In general, the higher, steeper rock faces that are seen in this panorama are limestones and dolomites; the lower, gentler, grass- and tree-covered slopes are sandstones and shales.

The primary erosional force that shaped this area is glaciation.

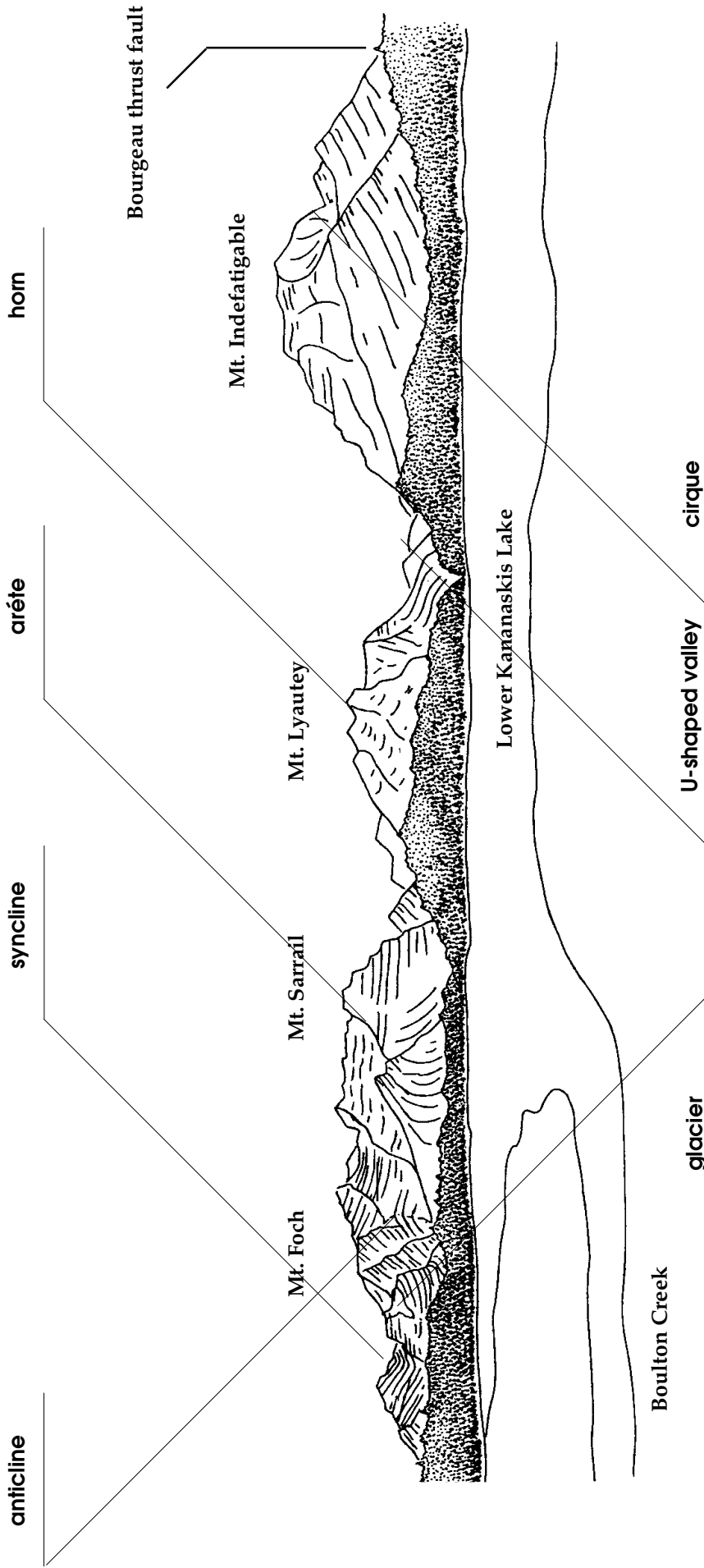

**Notes:**

The Bourgeau thrust fault separates Devonian Rock (370 million years old) from Jurassic rock (104 million years old). A difference of 200 million years is seen along the thrust fault line.

In general, the higher, steeper rock faces that are seen in this panorama are limestones and dolomites; the lower, gentler, grass- and tree -covered slopes are sandstones and shales.

The primary erosional force that shaped this area is glaciation.

### 3.3.3 CHALLENGE QUESTIONS

1. Using the figure showing glacial landforms as a guide, match the names of the various glacial landforms to their definitions.

1. tarn
2. cirque
3. arête
4. hanging valley
5. horn
6. col
7. U-shaped valley

- a lake that is found in a glacier-carved depression
- a low point, or pass, in a mountain ridge
- a bowl-shaped depression that was carved by a glacier
- a sharp peak that is formed when several cirques join at the top
- a knife-like ridge that separates two cirques
- a small, glacial valley that is suspended above the floor of a main valley
- a valley that has been carved from a V-shaped into a U-shape by a glacier

- \_1\_ a lake that is found in a glacier-carved depression*
- \_6\_ a low point, or pass, in a mountain ridge*
- \_2\_ a bowl-shaped depression that was carved by a glacier*
- \_5\_ a sharp peak that is formed when several cirques join at the top*
- \_3\_ a knife-like ridge that separates two cirques*
- \_4\_ a small, glacial valley that is suspended above the floor of a main valley*
- \_7\_ a valley that has been carved from a V-shaped into a U-shape by a glacier*

## 4.0 GLOSSARY OF TERMS

arête	knife-edged ridge between two cirques
anticline	an arch-shaped rock fold (opposite of a syncline)
bed	a single sedimentary layer (e.g., a sandstone or shale bed)
bedding plane	the surface between two beds
calcium carbonate	chemical name for the mineral calcite. The rock called limestone is composed of 100% calcite.
carbonic acid	a naturally occurring acid that forms when water is mixed with the carbon dioxide in the air.
chemical weathering	the chemical process that dissolves rock.
cirque	a bowl-shaped hollow in a mountainside caused by the digging action of a glacier
col	a low spot or "pass" on a mountain ridge; may mark the intersection of two valleys
delta	a fan-shaped body of sediments deposited in a lake or ocean at the mouth of a river.
drumlin	a tapered hill made of clay and rocks that is formed by a glacier.
erosion	the processes by which soil and rock particles are broken up and carried away by water, ice or wind.
glacier	a large, permanent collection of snow and ice that flows downhill at a slow rate (i.e. a few metres per year)
horn	a pointed mountain peak created by the formation of cirques on two or more sides of the mountain
hanging valley	a U shaped valley that intersects another valley, not at the bottom of the larger valley but part way up the valley wall
igneous rock	rock created by the cooling of molten magma
isostasy	the floating of the earth's solid crust upon the liquid mantle.



isostatic rebound	the upward movement of the earth's crust after a downward pressure has been removed.
lithification	the process that causes sediment to become rock.
mechanical weathering	the physical processes that break down rock.
metamorphic rock	rock formed from pre-existing rock by strong heat or pressure.
sediment	rock fragments of various sizes that have been deposited in a river, lake or ocean.
sedimentary rock	rock that consists of sediments bound together by some substance that acts as a cement
stratification	parallel layers or beds of sedimentary rock (the pages of a book can be said to be stratified).
subduction	a process that may occurs where continental plates meet, consisting of one plate (usually a continental plate) overriding a more dense plate (usually an oceanic plate)
syncline	a U-shaped rock fold (opposite to an anticline).
tarn	a lake that forms in the bottom of a cirque
U-shaped valley	a valley carved by a glacier
V-shaped valley	a valley carved by a stream or river
weathering	the process by which rocks are broken down by natural forces such as wind, water, and ice.

# 5.0 WRITTEN IN STONE

## Program Evaluation

Kananaskis Country Environmental Education materials have been developed to provide you with teacher-directed units of study. These are *constantly evolving documents* that undergo changes on a continual basis.

The purpose of this questionnaire is to find out if these materials are meeting your teaching needs. Your comments are valuable to us. Please take a few minutes to complete this evaluation so that we may continue to improve your materials.

School name	Grade level taught	Your name <small>(optional)</small>

★ How did you hear about the program?  
 workshop    administration    in-service    newsletter    fellow teacher  
 other (please specify) \_\_\_\_\_

★ Did you use all of the program?    yes    no  
 If you answered **no**, which part did you **not** use and why?  
 \_\_\_\_\_

★ On the bar line below how would you rate the program in the following categories:

	YES		NO
• appropriate for grade level (✓)		-----	
• clear instructions		-----	
• text easy to follow		-----	
• relevant to curriculum		-----	
• materials easy to use		-----	
• did you enjoy the material		-----	
• did your students like the material?		-----	
• program of appropriate length?		-----	

- Approximately how long did it take you to complete this material?  
 1-2 weeks                       3-4 weeks                       5-6 weeks  
 longer than one month       program was spread over the year
- Were you satisfied with how this material fulfilled the curriculum objectives?  
 yes                       no

If you **were not** satisfied, please elaborate: \_\_\_\_\_  
 \_\_\_\_\_

- Did you require any additional information to complete any part of the program?  
 yes                       no

If **yes**, please tell us what was required: \_\_\_\_\_  
 \_\_\_\_\_

- Would you use this material next year?  
 yes                       no

If you answered **no**, please tell us why: \_\_\_\_\_  
 \_\_\_\_\_

- Any additional comments about the program in general?

\_\_\_\_\_  
 \_\_\_\_\_

Thank you for completing this questionnaire. Please mail the completed questionnaire to:

Environmental Education Coordinator  
 Alberta Environment, Natural Resources Service  
 Kananaskis Country  
 Suite 201, 800 Railway Avenue  
 Canmore, AB T1W 1P1  
 Phone: 403-687-5508

# APPENDIX I

## RECIPE FOR HOME-MADE MODELLING CLAY

The following recipe provides enough clay for 30 students.

### **Ingredients:**

2 cups flour  
1 cup salt  
4 teaspoons cream of tartar  
4 cups water  
2 tbsp vegetable oil

### **Directions:**

1. Mix the dry ingredients together in a large saucepan.
2. Add the oil and water, then stir the mixture until it is smooth.
3. Cook over medium heat, stirring constantly until the mixture leaves the sides of the pan.
4. Remove from heat and knead the clay mixture until it reaches the desired consistency.

# APPENDIX II

## ACTIVITY: HOW TO MAKE A MOUNTAIN OF JELLO

---

This recipe can be used to illustrate folding, faulting, and glacial erosion in an interesting and unique fashion! The best part for the students is being able to consume the layers of jello once the demonstration is finished.

---

### Objectives

Students will observe first hand how erosion can change the shape of the earth to create different landforms.

### Materials

- 20 plates
  - knife
  - kettle
  - cake pan (23 x 33 cm, or 9 x 13")
  - two 85 gm boxes of orange jello (or other flavoured gelatin mix)
  - two 85 gm boxes of green jello
  - two 85 gm boxes of red jello
  - two 85 gm boxes of yellow jello
  - 8 packages (8 tablespoons) Knox unflavoured gelatin
- Note the following candies can be substituted with other types of candy such as jelly beans, licorice Allsorts, etc.
- gummy bears
  - gummy worms
  - Sunkist "dinosaurs"
  - ju-jubes



one 40 x 50 cm (16 x 20") sheet of thick, clear plastic - this can be obtained as "polyethylene" from paint stores or building supply stores. Do not substitute with sandwich wrap - it is too thin.

### **Instructions for the Teacher**

1. Line the cake pan with the sheet of clear plastic.
2. Mix two cups of boiling water with the two packages of orange jello and two packages (two tablespoons) of unflavoured gelatin.
3. Stir until the jello and the gelatin have dissolved.
4. Stir one cup of cold water into the jello mixture.
5. Place the pan into the refrigerator, ensuring that the mixture spreads evenly into the corner of the pan.
6. Place the pan into the refrigerator and wait until the mixture hardens completely.
7. When hard, place the first fossils onto the surface of the hardened jello: these will be the "oldest" fossils. On the first layer you could arrange ju-jubes in a "reef" shape, representing reefs in Devonian and Mississippian Alberta. Each jello layer can have a different type of fossil which is indicative of a different period of time. Alternatively, you could allow the jello mixture to attain a semi-solid consistency only, and then insert the fossils directly into the jello so that the fossils are actually contained within the body of the jello "bed".
8. Repeat this procedure with the red jello, allowing the red mixture to cool to room temperature before pouring onto the yellow layer. Be careful not to displace the "coral reef" while pouring. Once again, refrigerate until hard, then position the next set of fossils onto the red jello surface. Each jello layer can have a different type of fossil which is indicative of a different period of time.
9. Repeat the procedure with the green and yellow jellos, but do not place any fossils on the top of the last jello layer. Let sit overnight.

**CAUTION:** If you wait more than 24 hours before using this model, you will find that the layers will begin to separate, causing an interesting (but non-geological) configuration!

10. To remove the jello mountain, carefully lift the plastic out of the cake pan, and set on a flat surface.
11. By pressing the sides together a folded appearance will occur with the layers; any cracks or fissures that develop when you do this can represent faults in the rock.
12. Ask students to observe closely, and then use the butter knife to carve a V-shaped valley into the jello mountain. Have students save the resulting sediments on a plate for later consumption! Ask students what landform you have created, and point out the interesting pattern created by the exposed sediments.
13. You can carve a number of different landforms (or have groups of students carve them), using the same approach to have students to guess which landform you are creating. A few examples are:
  - a U-shaped valley
  - a hanging valley
  - a col, horn, or arrete

To illustrate a slow, erosional sequence, you may want to proceed by taking progressively deeper shavings from the jello mixture, exposing different layers over time.

14. When the examination of landforms is completed, the polite consumption of this sedimentary masterpiece is then in order.

## APPENDIX III: GEOLOGICAL TIME AND KANANASKIS COUNTRY

Era	Period	Years before present (millions)	Distance on 5 m tape (m)	Major Events	Age of...
Cenozoic	Quaternary	.01	0.00001	10,000 years ago - last glacier leaves Kananaskis Country	Flowering Plants and Mammals
	Tertiary	1.0	0.001	2 million years ago - Ice Age and first evidence of man	
Mesozoic	Cretaceous	65	0.065	65 million years ago - formation of Rocky Mountains begins	Crustal Bending
	Jurassic	135	0.135		Reptiles
	Triassic	180	0.18		Non-flowering Plants
Paleozoic	Permian	230	0.23		Extinctions
	Pennsylvanian	280	0.28		Amphibians
	Mississippian	310	0.31		(Carboniferous Period)
	Devonian	345	0.35		Fishes
	Silurian	405	0.41		Land Animals
	Ordovician	425	0.42		Marine Invertebrates
	Cambrian	500	0.50	570 million years ago - first rocks formed in Kananaskis Country	Trilobites
	Pre-Cambrian		570	0.57	4.6 billion years ago - formation of the earth
		4,600	4.6		



ALBERTA ENVIRONMENT

# "ROCK NOTES"

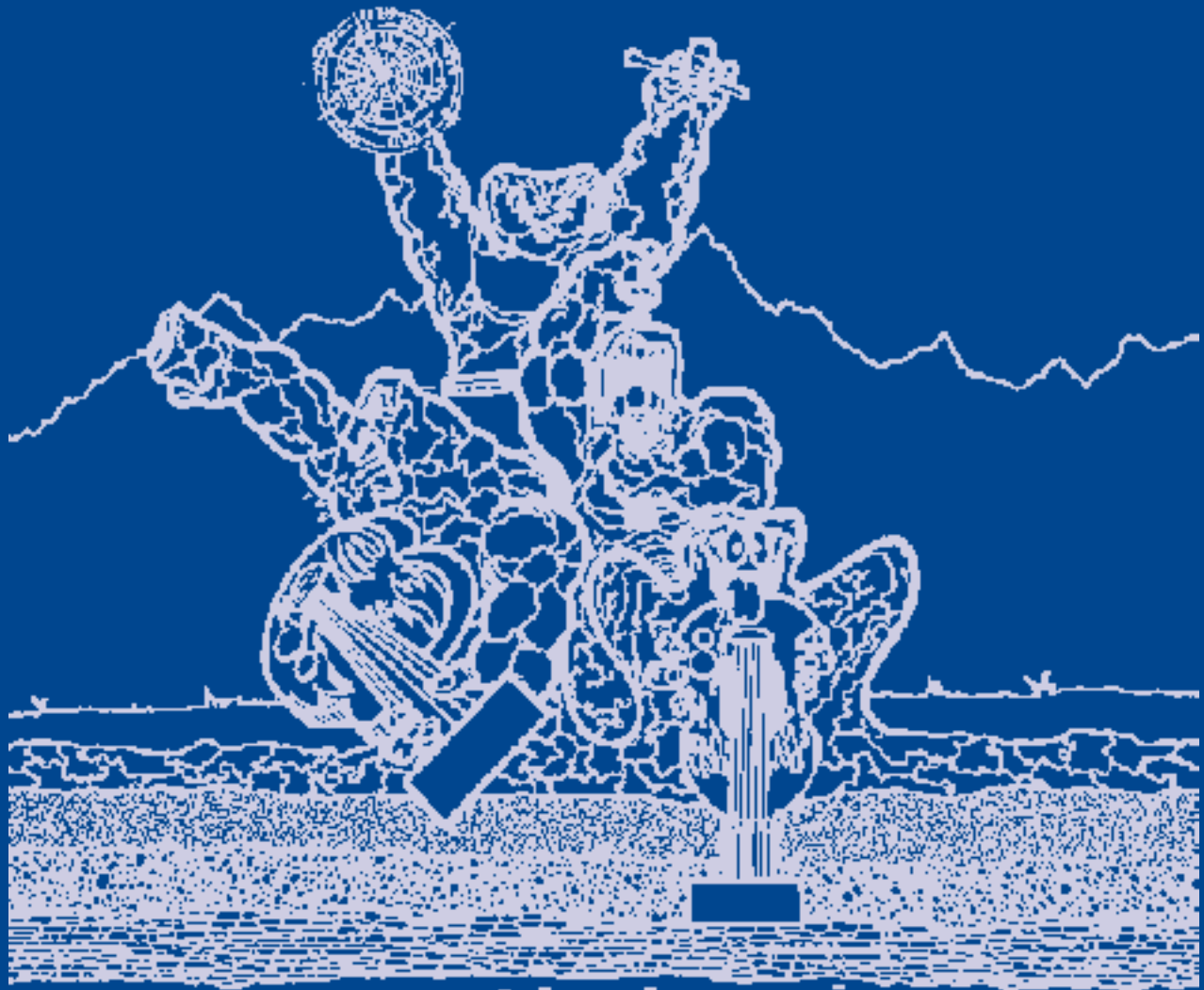

*STUDENT BOOKLET*



Alberta  
ENVIRONMENT

*Kananaskis Country*

# TABLE OF CONTENTS

	Road Log: Calgary to Barrier Lake	1
Stop #1:	Deposition of Sediments	5
	Background Information	5
	Activities	7
	Challenge Questions	9
	Road Log: Barrier Lake to Ribbon Creek	11
Stop #2:	Formation of Rocks	12
	Background Information	12
	Activities	13
	Challenge Questions	15
	Road Log: Ribbon Creek to Galatea Parking Lot	17
Stop #3:	Mountain Building	18
	Background Information	18
	Activities	22
	Challenge Questions	23
	Road Log: Galatea Parking Lot to Lower Lakes Day Use Area	24
Stop #4:	Erosion	26
	Background Information	26
	Activities	29
	Challenge Questions	30
	Glossary Of Terms	32

*In every rock lies a story...*

**ROAD LOG:  
CALGARY TO BARRIER LAKE**

<u>Km</u>	<u>Comments/Questions</u>
0	Intersection of Trans-Canada Highway and the entrance to the Canada Olympic Park (traffic light location). If you have a trip odometer, set it to zero here.
3.0	Valley Ridge Overpass
3.7-3.8	To the right you can see a large valley with a smaller valley cut into it. What do you think would cause this to happen?

\_\_\_\_\_

\_\_\_\_\_

\_\_\_\_\_

18.8	Geologists claim that by examining the road cut to the right they can tell that a very large lake once existed in this area. On what grounds do you think they could make this claim?
------	---

\_\_\_\_\_

\_\_\_\_\_

\_\_\_\_\_

25.2 (Jumping Pound Creek bridge)

We are at the spot where, unseen beneath our feet, the Plains turn into the Foothills. The rock layers beneath the ground surface begin to show the bending and deformation caused by the same forces that built the Rocky Mountains.

The bedrock is Cretaceous in age. This means that these rocks were formed at the time that dinosaurs became extinct. A thin layer of a rare metal called Iridium was deposited in the rock layers at this time, and it has led scientists to believe that the extinction of the dinosaurs was caused by a huge meteorite made out of Iridium that struck the earth around 65 million years ago.

How could a meteorite hitting the earth have caused the extinction of all of the dinosaurs?

---

---

27.2 The outcrop of rock to the right belongs to the Cretaceous period discussed above. These rocks were formed from sediments that probably lay along the shoreline of an ancient river, lake, or sea. How can we tell from looking at the rocks that they were formed along an ancient shoreline?

---

---

31.7-32.2 (Shell Oil's gas and sulphur plant to the right)

At this very moment you are driving over the Jumping Pound Gas Field. This field was discovered in 1944 and produces natural gas from rocks that were formed during the Mississippian age (approximately three hundred million years ago). During the Mississippian age, Alberta was submerged beneath inland tropical seas and swamps. These rocks now lie approximately three to four thousand feet below you.

38.0-38.4 On the left hand side of the bus, you can see sedimentary rocks that have been tilted from their original horizontal position by the same forces that created the Rocky Mountains.

39.1 Scott Lake Hill

This hill is the second highest point on the Trans-Canada highway (Rogers Pass is the highest). Did you feel your ears "pop" due to the decreased air pressure?

45.4-48.6

(and 49.0) A **drumlin** is a low hill that is created by a glacier, and is shown on the next page.



### Drumlin - from the Trans-Canada highway, looking north

When a glacier moves over the ground, sometimes it ploughs the earth into smooth shapes beneath it. One of these shapes looks like an upside-down spoon, and is shown above. It is called a drumlin.

Show the direction of movement of the glacier using an arrow (hint: in this area, the glaciers moved in a west-to-east direction). Where do you think the glacier that formed this drumlin came from?

---

---

49.9 Look at the material exposed beside the road to your left - it looks as if a gravel truck dumped it there. A large glacier dumped its load of **glacial till** here. Any material that has been transported and deposited by a glacier is called **glacial till**.

58.1-60.1 More drumlins.

64.0 Interpretive sign on the right side of the road - **stop here** in the roadside space provided for vehicles.

You can see Mt. Laurie, also known as Mt. Yamnuska, to your right. Mount Yamnuska can be called a "split-level" mountain, because it has two distinct levels. The steep cliffs above are Cambrian in age (approximately 550 million years old), and are the oldest rocks found in Kananaskis Country. The gradual slopes underlying the cliffs are composed of younger rock, and were formed when mountain building was just beginning in Alberta - around 78 million years ago, during the Cretaceous age.

In a typical sedimentary bed, would you find older rocks overlying younger rocks? Explain why or why not.

---

---

Sketch Mount Yamnuska in the space provided. Label the Cambrian rocks, the Cretaceous rocks, and the location of the fault that separates the two.

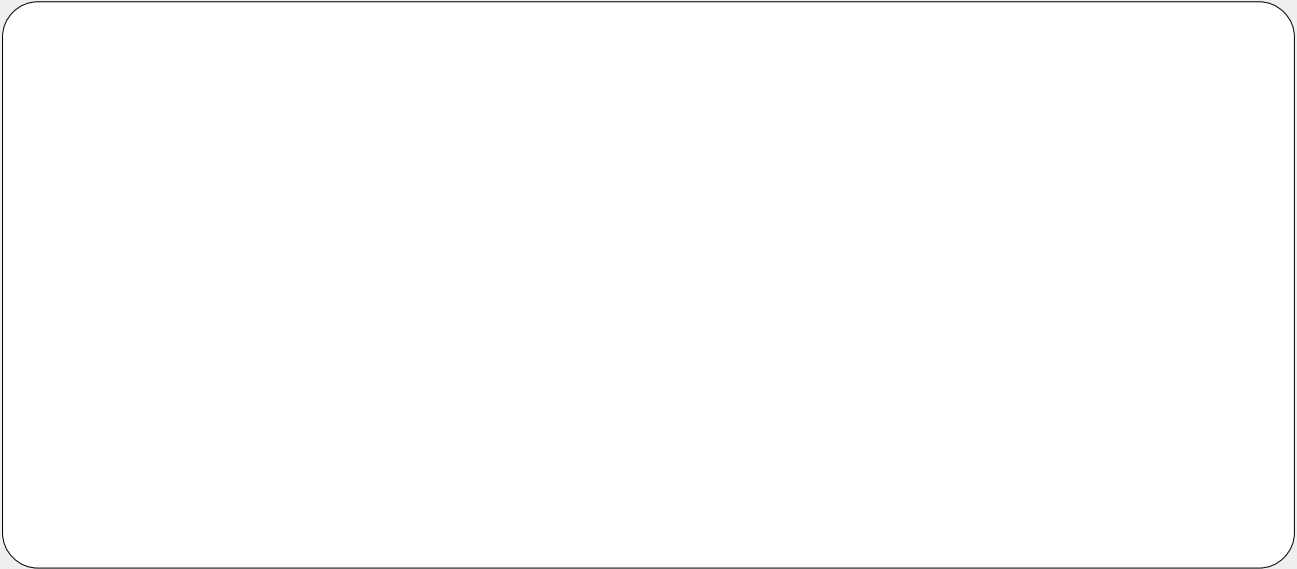

**Sketch of Mount Yamnuska from Highway 40**

Read the interpretive sign. Now look at the land around you. Why do you think we normally find clay deposits in very flat-lying areas?

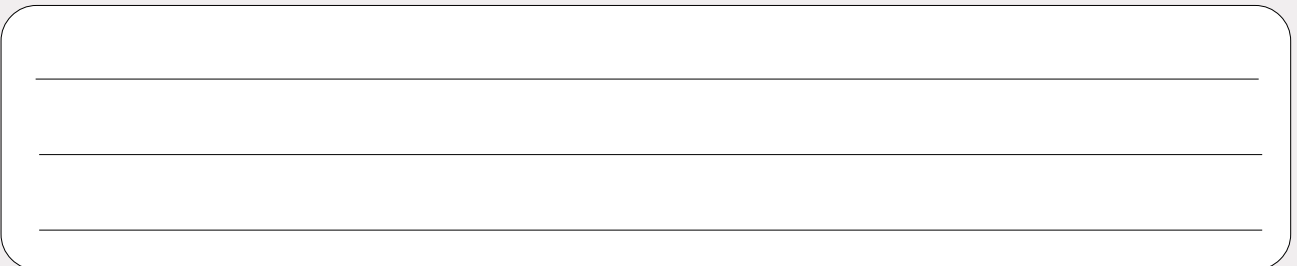

71.4 You have now officially entered Kananaskis Country!

72.9 Geologists speculate that this area was once covered by a large glacial lake called Sibal Lake. How do you think they know this? (Hint: if geologists made a soil map of this area, they would be able to tell from the map how large the lake was).

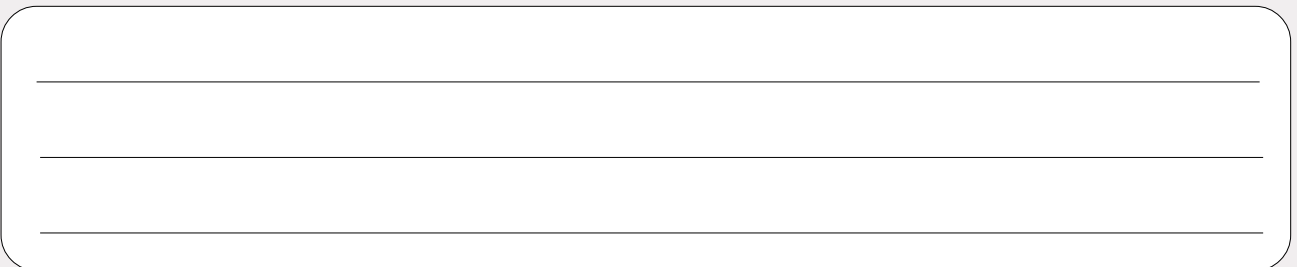

74.5 To your right, McConnell Ridge (also known as Barrier Lake lookout) is another example of a "split-level" mountain. The steep upper cliffs of this mountain are Cambrian aged, while the slopes below are younger Cretaceous-aged rocks - just as was the case for Mt. Yamnuska.

# STOP #1: DEPOSITION OF SEDIMENTS

## BACKGROUND INFORMATION

The story which will unfold during this field program began 350 million years ago, when most of Canada (including Kananaskis Country) was covered by a warm, shallow, tropical sea. This sea was bordered by lands to the north, east, and west. As the land was exposed to wind and water, it gradually wore down and was transported by rivers to the sea. Over hundreds of millions of years, billions of tonnes of sediments (gravels, sands, silts and clays) were deposited layer upon layer on the sea bottom.

As the rivers flowed, they had enough energy to carry quite a sediment load; but upon reaching the sea, the current that provided the energy to carry the sediments was lost. Heavier sands and gravels settled to the bottom first. However, lighter silts and clays remained suspended in the water for a longer time, and so eventually settled to the bottom at greater distances from the river mouths. Eventually, large deltas formed at the mouths of these rivers where the rivers flowed into the shallow seas.

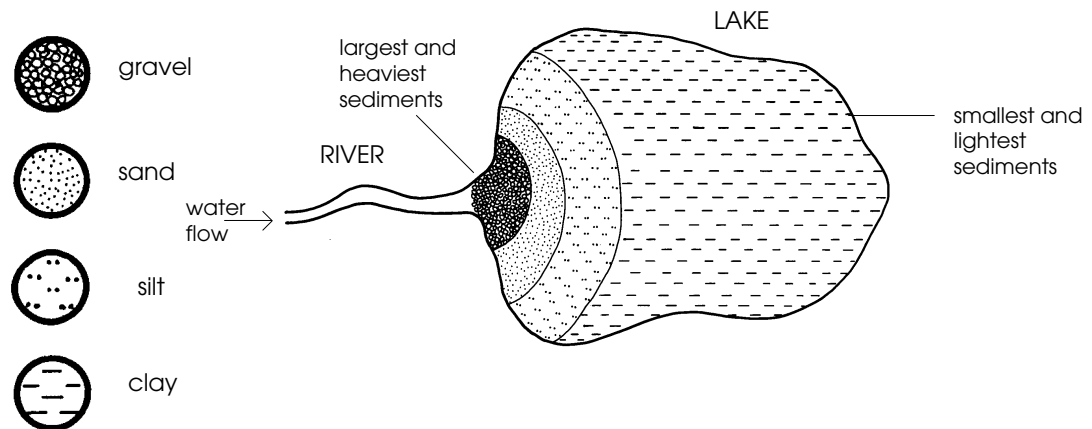

### Sediments deposited in a delta

In the clear, shallow areas of the oceans not influenced by river sediments, marine organisms thrived and coral reefs formed. These areas were known as life zones.

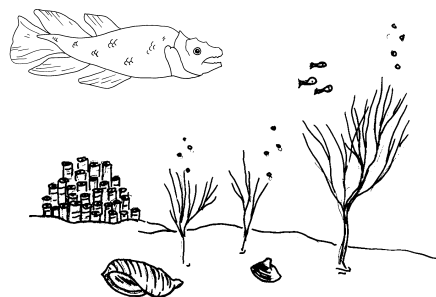

### "Life Zone"

Many of these marine animals had shells and skeletons made of the mineral calcium carbonate ( $\text{CaCO}_3$ ). When these organisms died, their shells and skeletons accumulated on the ocean floor. Through time, this organic material was gradually broken down into smaller and smaller pieces by the gentle rolling action of the water on the ocean bottom, eventually becoming “calcite sediments”.

Over time, the deposition of various types of sediments (clay, silt, sand and gravel) created layers on the ocean floor. This horizontal layering (like a layer cake) is called **bedding** or **stratification**. The divisions between the different types of sediment layers are called **bedding planes**.

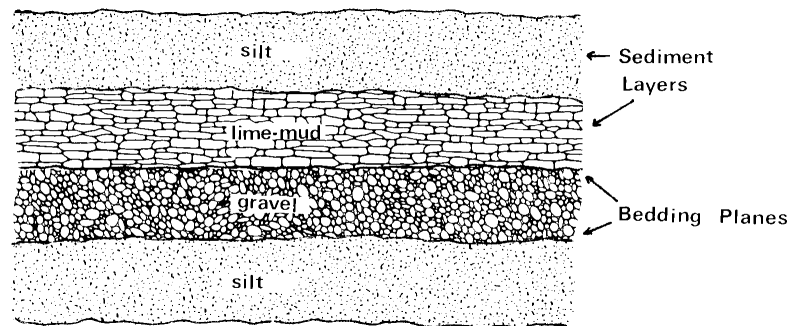

### Stratified Sedimentary Beds

As this process continued, younger layers were deposited on top of older layers. This same layering process can be seen happening today in the oceans and seas, and even in Barrier Lake. You can actually see the Barrier Lake delta forming at kilometre 80.4 of the field study today.



## ACTIVITIES

1. Find a partner for this activity.
2. Each partner should fill a jar three-quarters full with water from Barrier Lake.

**CAUTION:** The shoreline of Barrier Lake slopes steeply away underneath the water. Stay well away from the edge of the water.

3. There are four sizes of DRY sediment that can be found around this shoreline: gravel, sand, silt, and clay. Collect a sample of each kind, and place each type of sediment in a separate bag.

**How to tell sediments apart:** Gravel and sand can be distinguished on the basis of size. (Gravel diameters may vary between 2 and 20 mm; sand size varies between 0.0625 mm and 2 mm). Clay usually appears as a very blocky and cohesive unit that clings together until added to water, and feels somewhat greasy to the touch. Silt grains are intermediate in size between clay and sand (it measures 0.004 to 0.0625 mm in diameter); silt grains are too small to be seen clearly with the naked eye, but do not share the blocky and cohesive nature of clay.

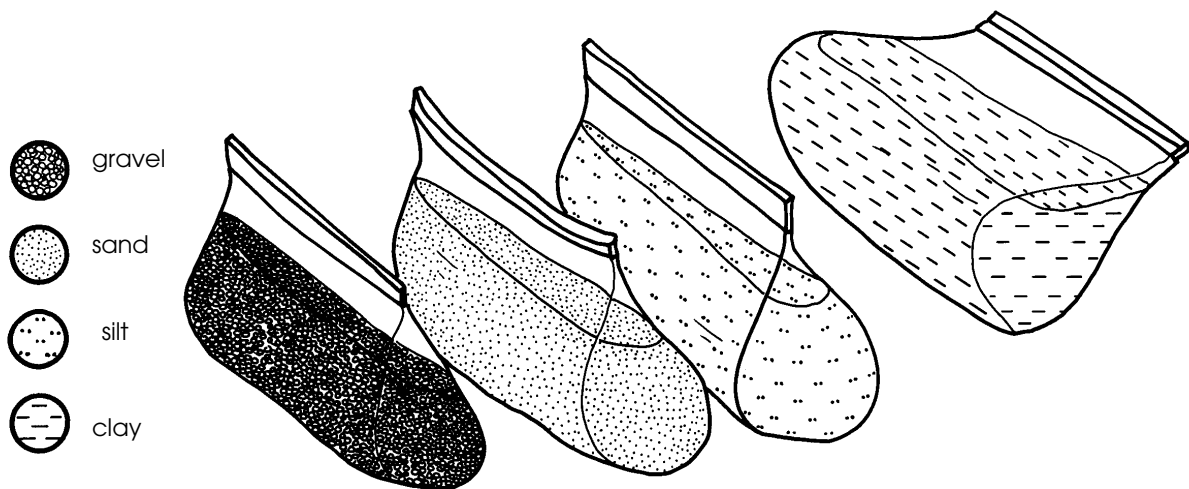

4. For each sediment type: fill your jar lid with sediment so that the soil is level with the lid of the jar. Then, drop the sediment into the jar. (Note: for the clay and silt, rub it between your hands so that it is not all stuck together). Observe the different rates at which they settle. In the space below, record your observations:

\_\_\_\_\_

\_\_\_\_\_

*Note: Remember to rub the clay and silt between their hands, the materials will tend to stick together (cohere) and will settle faster than an individual grain would.*

5. Measure out another "level jar lid" of each sediment type, and mix them thoroughly together in your spare bag. Drop this mixture into the water in the second jar, shake vigorously for ten seconds, and wait five minutes. BEFORE you actually do this, however, PREDICT what sediment layers will form on the bottom of the glass jar, based on your results in #4.

My prediction:

\_\_\_\_\_

\_\_\_\_\_

\_\_\_\_\_

On the jar illustrated below, draw the different sediment layers as they appear, using the following symbols to represent the sediment types:

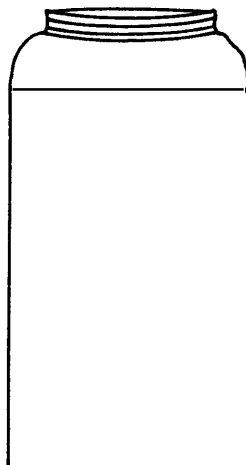
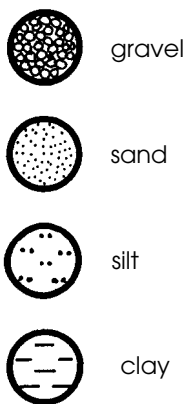

**Jar of Sediment**

# CHALLENGE QUESTIONS

1. The level of an ocean's shoreline constantly fluctuates for a variety of reasons. As a result, the same offshore area will receive not just one type of sediment over the years, but an assortment of sediment types, as illustrated below. Interpret the history of the area illustrated by looking at how the sediment was deposited. Why were different sediments deposited in different places?

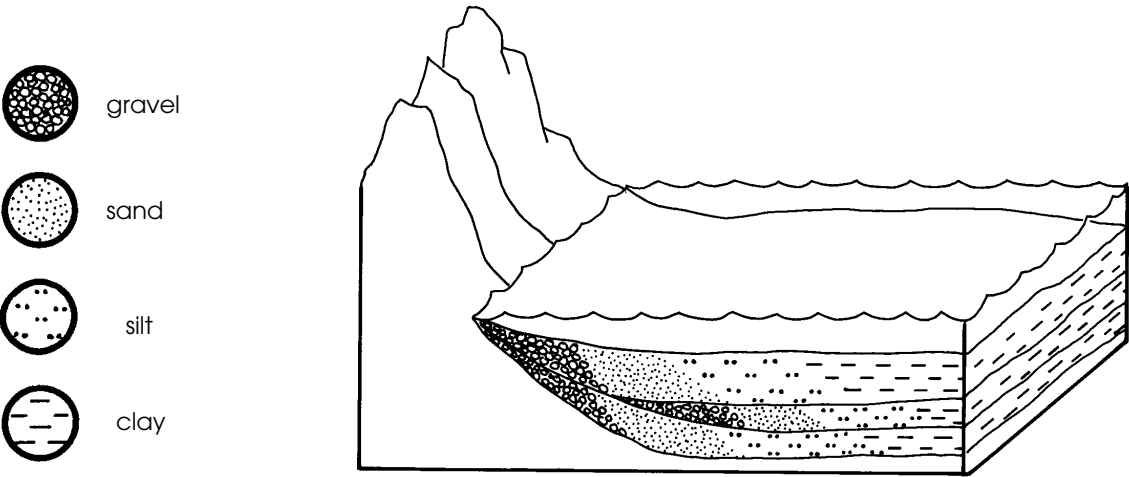

\_\_\_\_\_

\_\_\_\_\_

\_\_\_\_\_

2. A geologist made a geological map of sediments, which is shown on the next page. How does the average grain size change from west to east: does it increase or decrease? Where were the shallow and the deep parts of the sea that once covered this area?

\_\_\_\_\_

\_\_\_\_\_

\_\_\_\_\_

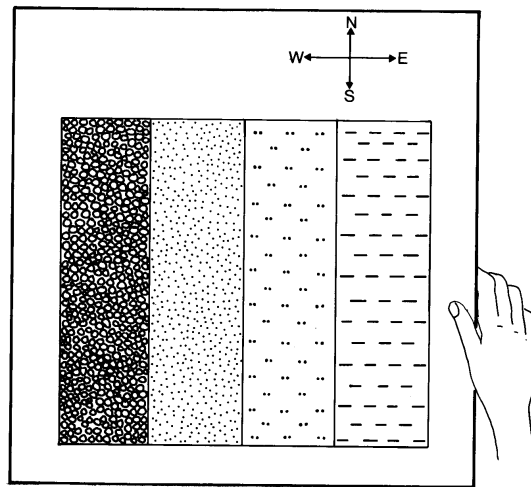
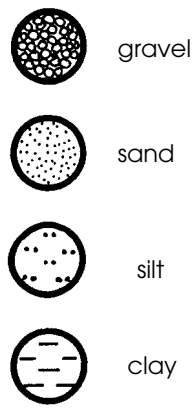

3. Quigley Engineering Co. has dug a large, square, room-shaped block out of the bottom of a lake for engineering purposes. Assuming that sediments will be deposited onto the lake bottom, draw what geologists would see in the rock record three million years from now. Describe the process of what occurs in the space provided.

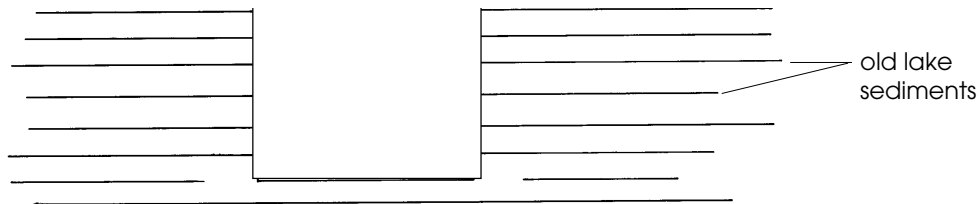

---



---



---

## ROAD LOG - BARRIER LAKE TO RIBBON CREEK

- 79.2 Here's a sixty-four dollar word to impress all your friends with - "Uniformitarianism". It means that processes that occurred in the past, such as rock-forming, are also occurring today. Based on this, what might eventually happen - after millions of years - to the sediments that are now being deposited at Barrier Lake?

---

---

- 79.5 Another possible name for a road cut would be "a slice through time". Why?

---

---

- 80.4 From here you have an excellent view of the delta that is forming in Barrier Lake, as discussed in Stop #1.

Is the river a high-energy or a low-energy environment compared to the lake? Which would you expect to find deposited in the river: sand, or gravel? Why? Draw an arrow pointing to where the different sediment types might be deposited.

---

---

### BIRD'S EYE VIEW OF A TYPICAL DELTA

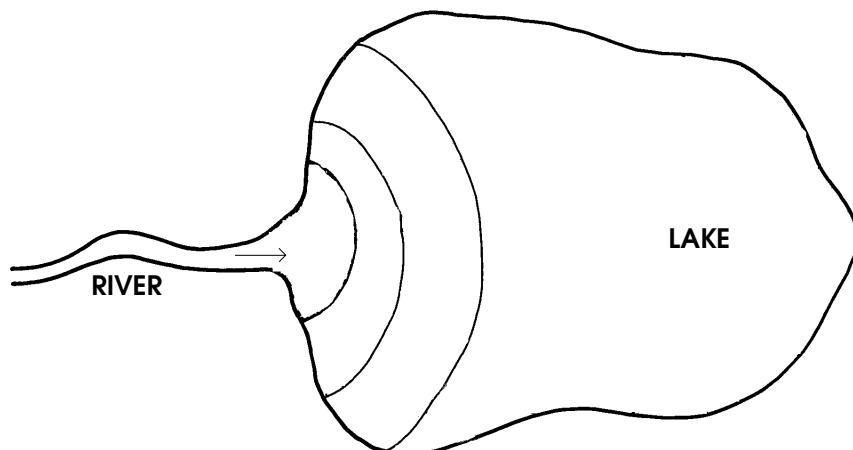
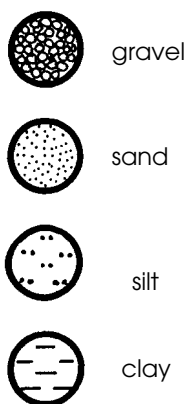

90.5 Roadside interpretive sign for Nakiska Ski area - STOP the bus in the roadside vehicle space provided.

To the left of the ski hills on Mount Allan you can see the scar left by the reclaimed Mount Allan coal mine. In the 1940's this strip coal mine was opened on the east slope of the mountain. Due to a number of conditions, this mine proved not to be economically feasible, and the operation closed in 1952. The coal found at this location was formed during the Cretaceous era, when swamp forests thrived in this area.

## STOP #2: FORMATION OF ROCKS

### BACKGROUND INFORMATION

After being buried for millions of years, the layers of sediment begin to change. Pressure from the weight of billions of tonnes of sediment produces heat, which causes chemical change. As a result, the sediments became rock. In addition, as the sediments are buried deeper and deeper, they were also subject to high temperatures radiating from the earth's molten core. This heat and pressure causes the sediment grains to cement together, forming sedimentary rock. The process of loose sediments turning to stone is called **lithification**, and is one of the steps of the rock cycle.

Different kinds of sedimentary rock are formed, depending on the type of sediment. For example, sand becomes sandstone, silt becomes siltstone, and the clay becomes claystone or shale. The thick beds of calcite-rich sediment, made from the shells and skeletons of marine organisms, eventually becomes limestone, which is the most widespread sedimentary rock in the world.

#### Notes:

1. Calcite-rich sediments are a different type of sediment from those considered in Stop #1. Gravel, sand, silt, and clay are formed from the erosion of rock; sediments that contain calcite are only formed on the bottom of warm marine seas, and eventually form limestone.
- 2) Two other major rock types are found in the world. These are igneous rocks, which are formed from cooled magma, and metamorphic rocks, rocks that have been "cooked" at extremely high temperatures. These rock types are very rare in Kananaskis Country, and have usually been transported by glaciers to their present location.

## ACTIVITY

1. What happened to the people below as more people were added to the top of the pyramid?

---

---

---

2. Name other important ingredients (missing from this activity) that are needed before sediment can turn into stone?

---

---

---

### Rock Identification

1. Each sedimentary rock has features which allow us to identify it and to discover what its origin is. *Use The Sensory Guide to Rock Identification* (next page) to help you identify three different rocks that you find on the ground in the area around Ribbon Creek. In the space below write their names, where you found them, and the kind of environment that they were formed in. Remember to return the rocks once you have identified them.

	<u>Rock Name</u>	<u>Location Found</u>	<u>Where the Sediments were Formed</u>
a)	<i>sandstone</i>	<i>along creek bank</i>	<i>near a beach</i>

b)

c)

d)

Why is it that we can find several different rock types in the area of Ribbon Creek?

---

---

---

# SENSORY GUIDE TO IDENTIFYING THE ROCKS OF KANANASKIS COUNTRY

Begin Here!

**Break the Rock**

(put the rock inside a sock and break it with a hammer)



Does the rock have layering and rounded grains,  
OR does it have sparkling crystals?

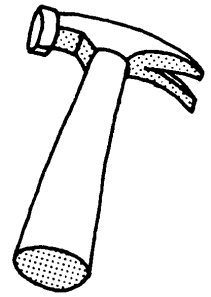

Layering and rounded grains

can't decide

Sparkling crystals

1. Are the grains larger than sand-sized?

2. Smell the freshly-broken surface:  
does it smell like rotten eggs?

No

Yes



**CONGLOMERATE**

Rub the rock against your teeth.  
Does it feel...

Like a  
jackhammer?

Gritty?

Smooth?



Can you see  
individual grains  
clearly?

Are the individual  
grains too small  
to be seen?

yes

no

yes

yes

**SANDSTONE**

**SILTSTONE**

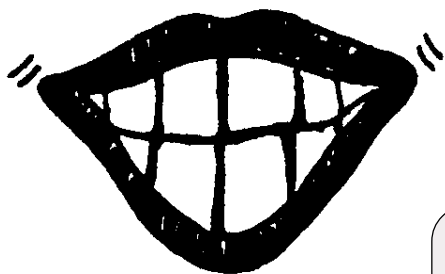

Do you get a "mud"  
when you wet the  
weathered surface?

**SHALE OR  
SILTSTONE**

Yes

No



Add HCl to the  
rock, and then  
look and listen.  
What fizzes?



The rock  
doesn't fizz.

Go to 1.

Only the fresh  
surfaces (not the  
weathered ).

Both fresh  
and  
weathered  
surfaces.

**DOLOMITE**

**LIMESTONE**



## CHALLENGE QUESTIONS

1. Match the rock type with the type of sediment that it is formed from.

**Sediment**

silt  
gravel  
sand  
clay  
lime mud

**Rock Type**

conglomerate  
limestone  
shale  
sandstone  
siltstone

2. When you add HCl to some rocks they fizz, due to a reaction with the calcite in the rock. What do you think would happen to a mountain of limestone in an area with an acid rain problem?

---

---

3. Some sandstones “fizz” when acid is applied to them, even though the sand **grains** are not made of calcium carbonate. Why might this happen?

---

---

4. Do you think limestone could help solve the problem of acid indigestion? Hint: find out what *Tums* and *Rolaids* are made of.

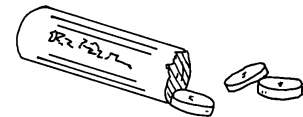

---

---

5. Rivers and lakes in the foothills and mountains of Alberta tend to be less acidic than those in Ontario and Quebec, for two reasons. The first reason is that we receive less acid rain here than in Eastern Canada. What do you think the other reason is? (Hint: some of our mountains are limestone).

---

---

---

6. The diagram below, entitled *Rock Cycle*, is incomplete. More arrows could be added than just the five shown here. Draw an arrow between two of the boldface words and describe the process that you think has to occur. There are several possibilities: for example, can a sedimentary rock become a sediment? (Yes, it can). What processes would have to occur? Write them in, and then repeat the procedure for a second arrow.

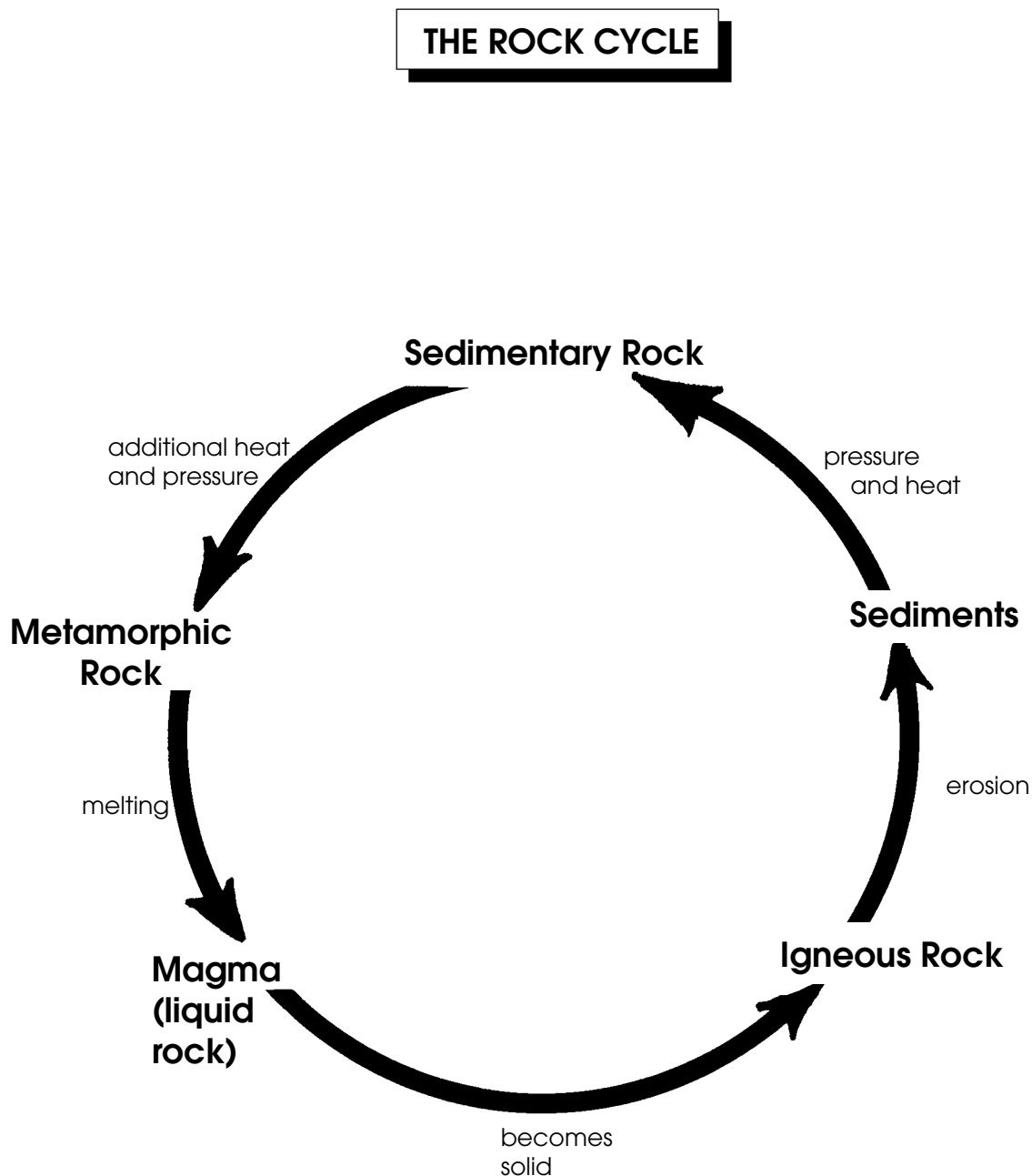

## ROAD LOG - RIBBON CREEK TO GALATEA PARKING LOT

- 96.4 (View of Kananaskis Village to the west)  
The terrace-like formation that the Kananaskis Village is built on was deposited by a glacier, and is called glacial till. What do you think the glacial till is made up of?

---

---

- 97.4 (Mount Kidd to the west - right side of the bus)  
Like Mount Yamnuska, this is another "split-level" mountain: older rocks overlying younger rocks, separated by a fault. Keeping in mind the fact that limestones and dolomites are very hard rocks, while sandstones and shales are relatively soft rock, what type of rock do you think Mount Kidd's steep cliffs are made of? What about the gentle slopes below? Label these two rock types on the diagram below, and label where you think the thrust fault is.

---

---

---

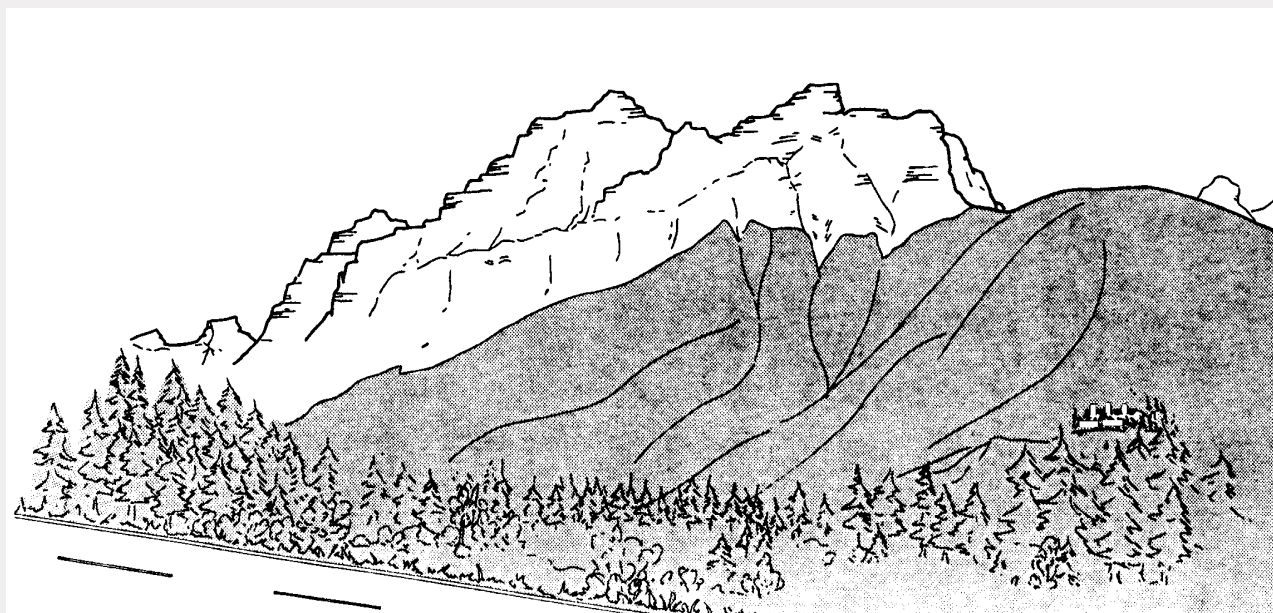

Mount Kidd, looking south-west

## STOP #3: MOUNTAIN BUILDING

### BACKGROUND

#### Plate Tectonics

Have you ever played with balloons full of water (water bombs) in the summertime? Let's compare the earth to a water bomb. The earth is similar to a water bomb in that it has a liquid core (which is hot), and a cold, solid crust which sits on the core.

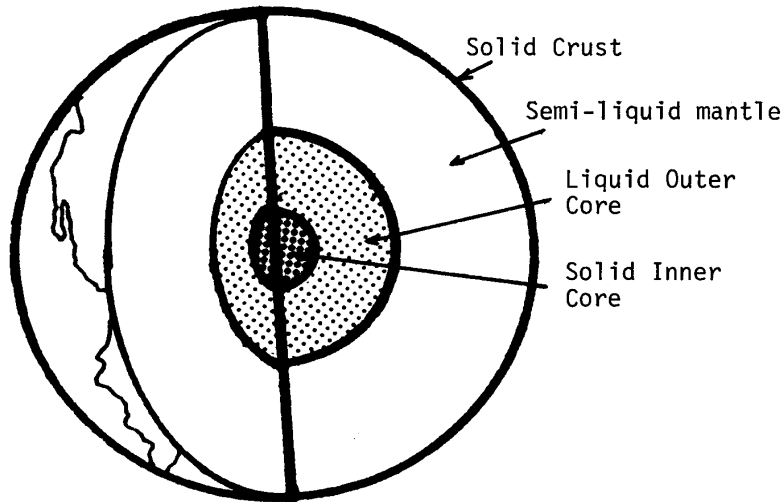

**Cross Section through the Earth**

The crust is not one smooth piece, like the skin of a water balloon; rather it is made of sections, or **plates**, that fit together like the pieces of a giant jigsaw puzzle. As you read these words these plates are sliding around on the surface of the earth's semi-liquid core at a very slow rate of only a few centimetres per year. Some of the earth's plates are slowly spreading apart from each other; others are being thrust underneath other plates as they approach one another; and still others are just sliding past each other. Figure 3-2 shows the names of these plates and their direction of movement. We live on the **North American Plate**. The theory of why plates form, disappear and change in shape and size is called **Plate Tectonics**.

#### Subduction

The North American plate and the Pacific plate to the west of it have been colliding very slowly for millions of years. As they collide, the thin Pacific plate is pushed down under the thicker North American plate, into the hot liquid mantle below. The active volcanos that are found in Washington state are caused by this process.

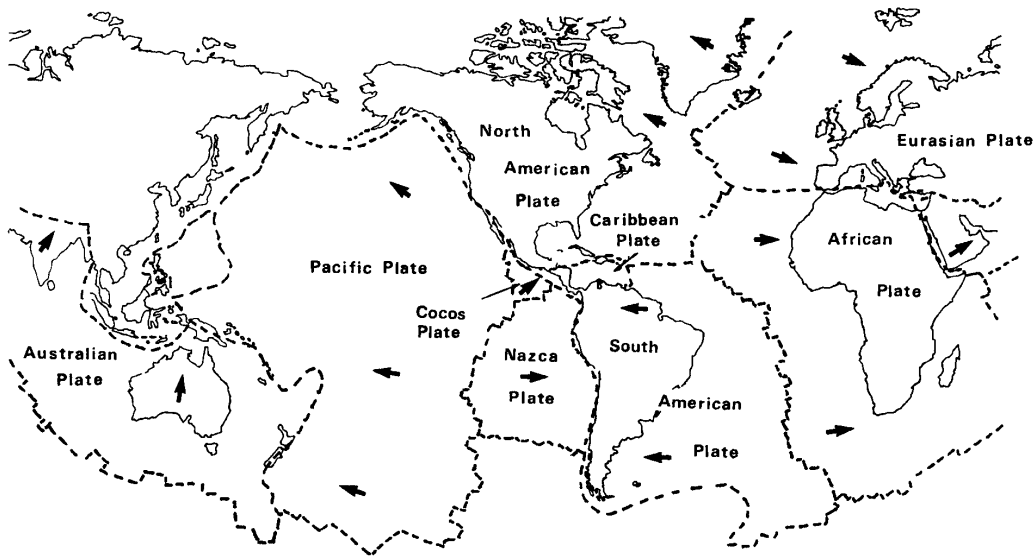

The Earth's plates

**Car Crash Analogy**

The pattern of deformation of the Rockies is especially apparent when seen on a geological map: virtually all of the mountain ranges are aligned in an approximately north-south direction. It is as if the continent of North America were a parked car that had been hit by a moving car (i.e., the Pacific Plate); the crash caused a series of ridges, parallel to the impact front, to occur on the west side of the continent, forming the Rocky Mountains. The ridges were formed where rocks to the west were pushed along thrust faults, up and over the rocks to the east. (See the next page for a description of thrust faults).

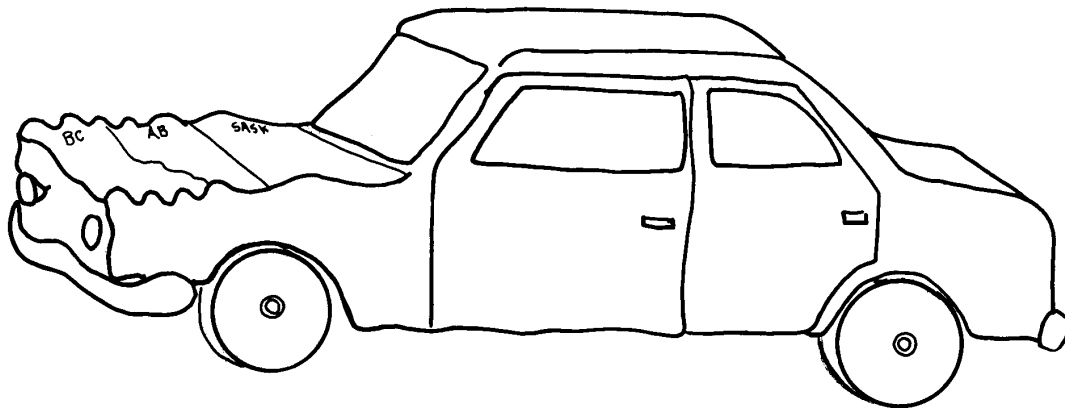

The "North American Continent" car; note the crumpled hood!

As a result of the subduction that was going on, all of the sedimentary rocks in the area of the present Rocky Mountains felt compression forces, as if the two plates were pushing at them from opposite sides. This compressional force caused the sedimentary rocks to bend and break. The bends in these rock beds are called **folds**. Large cracks in the rock beds are called **faults**. Folds and faults can both be seen in Kananaskis Country.

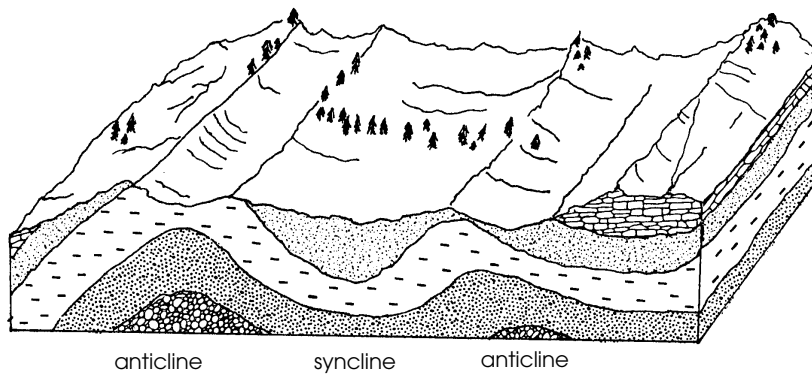

### Anticline and syncline folds

Thrust faults are caused by compression being exerted on a layer of sedimentary rocks. A fracture line develops, and the rocks above the fault line or fracture line are "thrust" above the rocks that lie below the thrust line. The two figures below illustrate this occurrence.

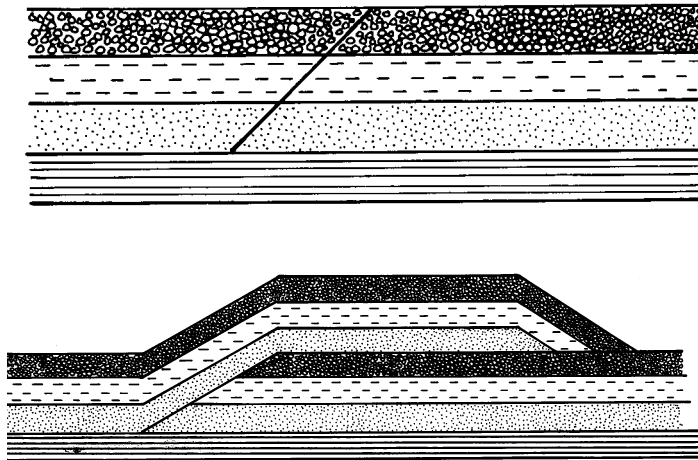

**Sedimentary rocks:  
before and after thrust fault**

### Isostatic Rebound

The forces resulting from the collision of the North American plate and the Pacific plate caused subduction to occur, as described earlier. Another effect of these huge compressive forces occurred further inland, along the boundary of Alberta and B.C: during the time these compression forces were active, the crust of the earth in this area was warped downwards, carrying the overlying rocks in the area downwards with it and creating a large depression in the earth's crust.

Let's return to the water balloon. Have you ever poked your finger into one? If you have, you might remember that, as you pressed your finger into the balloon, it felt as if the balloon were pushing back on your finger. This is because the water inside the balloon exerts a pressure on the skin of the balloon, and also on your finger when you press your finger into the balloon.

But what happens when your muscles in your finger get tired and you stop pushing into the side of the balloon? Your finger is pushed back to the surface of the balloon. The same thing happened to the earth's crust. Fifty million years ago, when the compressive forces ended, two things happened: the folding and faulting ended, and the earth's crust began to "bounce back" in the very same way as your finger is pushed back to the surface of the balloon. This "bouncing back" process is known as **isostatic rebound**. Even though the rebound process began 50 million years ago, it is **still happening - the Rocky Mountains are slowly being lifted up!** Why don't we feel as though we were in an elevator going up? Because the uplift occurs very slowly - at a rate that is measured in just a few millimetres per year.

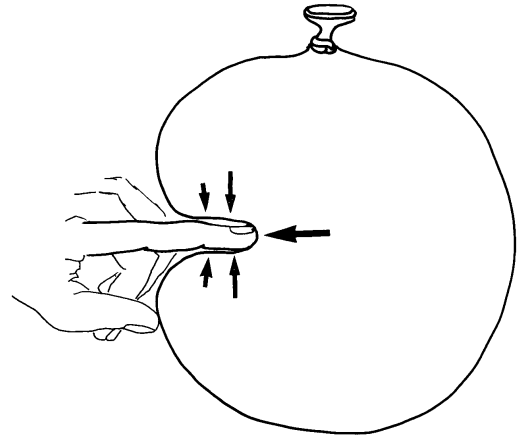

**Pushing on a Water Bomb**

Incidentally, you may have heard of isostatic rebound before if you have studied glaciation.

When continental glaciers covered North America with hundreds of metres of ice, their weight made the crust of the earth sink in much the same way. The melting of the ice resulted in the uprising of the crust over the period of hundreds of years through the process of isostatic rebound.

### **Boiling Soup Analogy**

How continental plates move can be demonstrated by heating soup or milk. As the hot liquid bubbles, a cooled "skin" begins to form on the surface, and soon creates a layer that is moved about by the hot liquid that circulates in a convection pattern beneath the surface. The pieces of skin act very much like the plates of the earth. The skin, in floating about on the surface of the liquid, tends to become wrinkled and distorted when it collides with other surface layers. These wrinkles are analogous to the mountain ranges that form when continental plates collide; the hot liquid underneath represents the earth's molten magma.

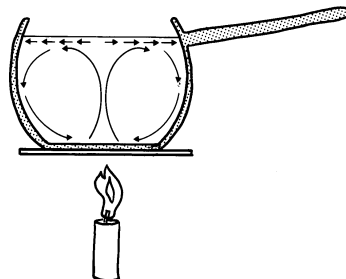

In addition, the skin in the middle of the pot tends to be spread apart by the uprising liquid in this area. This is also a good analogy to the earth's **rift zones**. Evidence of two plates' moving apart is found in the middle of the Atlantic Ocean, where an opening or **rift** is located. Uprising lava creates newly formed volcanic rock along this rift.

## ACTIVITIES

The earlier stops explored sediment accumulation and the creation of rocks; now it is time to look at how layers of rocks are deformed into the many different shapes and forms that we see today.

1. The diagram below shows sedimentary rock that has been bent into folds. A fold is simply a bend in what was once a flat-lying bed caused by forces in the earth.

Folds have two basic shapes. When the rock is bent upwards in the middle the fold is called an **anticline**; when the rock is bent downwards in the middle the fold is called a **syncline**. Label the synclines and anticlines that appear in the diagram below.

### Anticlines and synclines

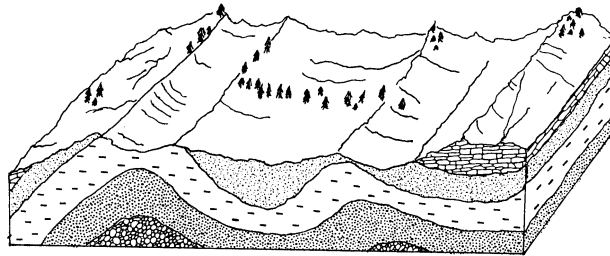

2. Look about you. In the rocks of one of the mountains the layers have been folded to form an anticline and a syncline. Label them on the diagram below.

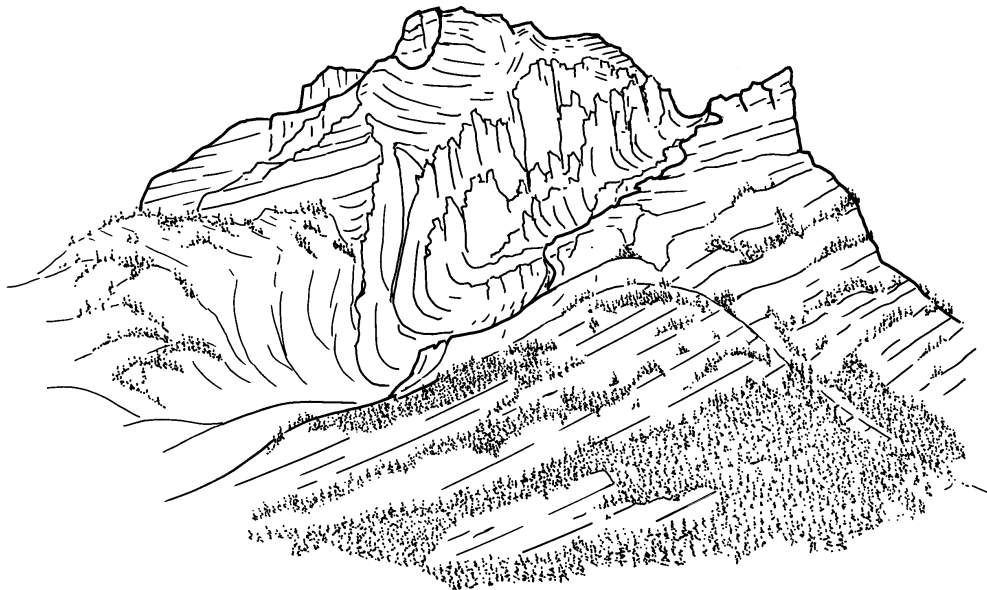

### Mount Kidd anticline and syncline



## CHALLENGE QUESTIONS

1. Using what you know about the appearance of thrust faults, explain how mountain ranges can be compared to shingles on a roof.

---

---

2. Indicate on the diagram below the direction you think the rock layers on either side of the Mount Rundle thrust fault moved.

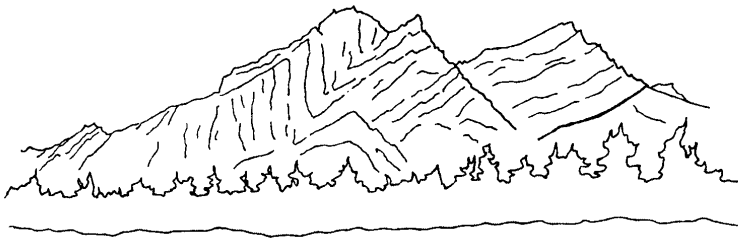

**View of Mount Kidd, looking north**

3. What would happen to a trampoline mat if, over several hours, you continually piled rocks onto it?

---

---

4. During the formation of the Rocky Mountains, the thrust fault activity caused a very thick layer of rocks to be deposited. Remembering what happened to the mat, what do you think this weight did to the earth's crust?

---

---

5. When the rocks are removed from the trampoline mat, it will spring up again. Rock material is presently being removed from the Rockies by erosion. What effect do you think this would have on the earth's crust?

---

---

## ROAD LOG: GALATEA TO LOWER LAKE DAY USE AREA

106.7 A very large-scale “slice of time” can be seen to your right. Here, the slicing was not caused by a road crew, but by a much larger force, which you’ll find out about at your last field study stop.

115.2 Fortress Junction.  
What might have caused the large “bowl-like” formation in the mountains to your right? Hint: The “Great White Chisel” has left yet another clue to its existence here..

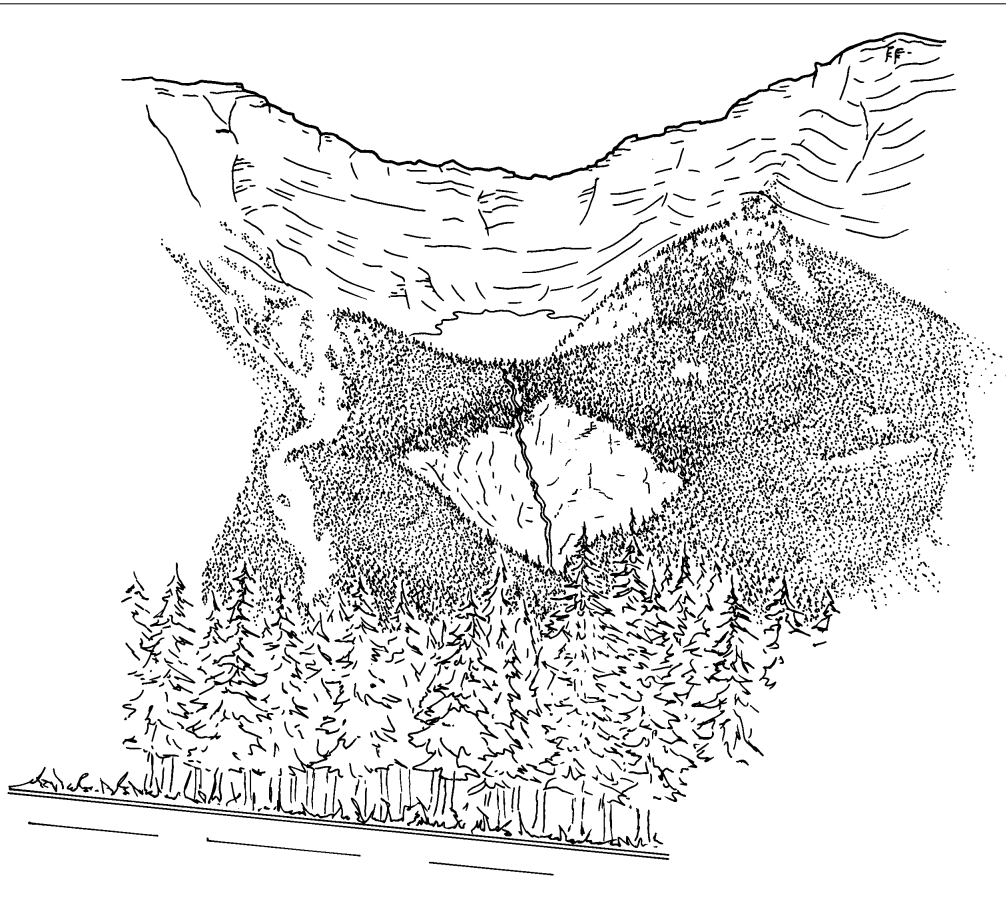

**Cirque at Fortress Junction - looking west**

118.7 Grizzly Creek marks the northern boundary of Peter Lougheed Provincial Park.

119.4 What would have created the bare patches that extend downwards from the top of the mountain to your right? Hint: this occurrence happens most often in winter and early spring...

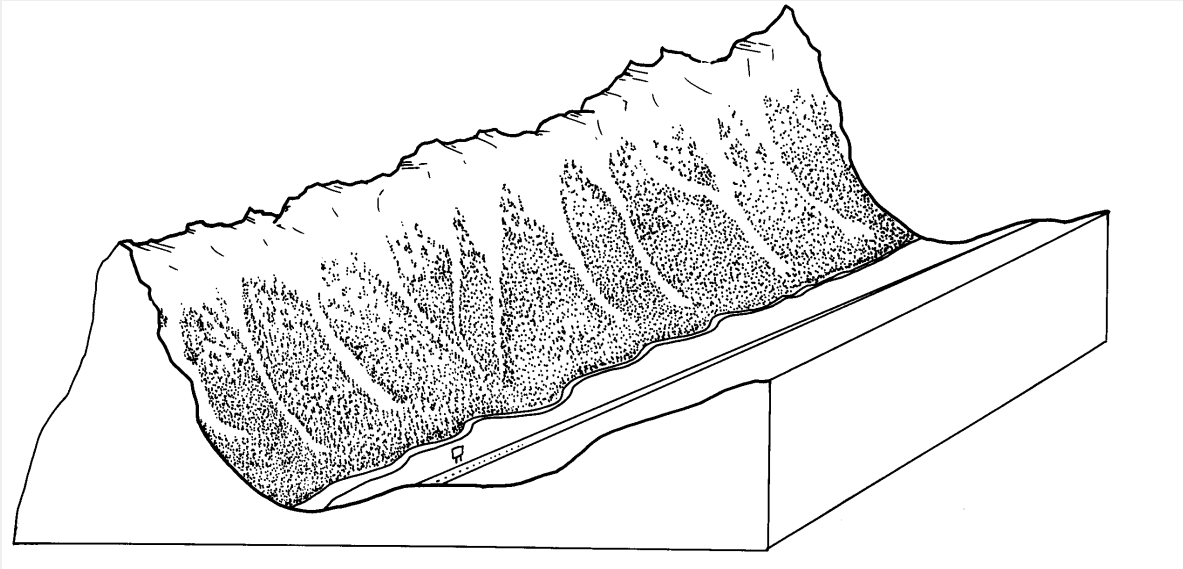

---

---

---

120.7-122.2 (Elective stop at the crest of the hill)

At first glance, the rock slabs to your left may seem rather plain. But upon closer examination you will see fossilized ripple marks. Approximately 200 million years ago, these ripple marks were formed in sand and silt by ocean currents. Geologists speculate that at the time that these were forming, a large coastline existed in this area, and the first crocodiles, lizards and turtles were beginning to swim the earth's waters.

Why is this ancient sea bottom now standing on its side?

---

---

---

## STOP #4: EROSION

### BACKGROUND

First, sediments were buried beneath thousands of tonnes of other sediment; next, huge pressures and heat transformed these sediments into layers of rock; then, tremendous forces bent, twisted, crumpled and broke the rock layers. What other forces could the Rocky Mountains possibly be subjected to?

# DESTRUCTION!

From the moment the Rockies first started to cast shadows on the plains, they have been attacked by natural processes that seem bent on destroying the mountains. **Weathering** breaks the rocks down, and **erosion** carries the fragments to new locations. Together, these processes began to relocate the sediments that took millions and millions of years to become mountains.

On this field study, look for these weathering and erosional processes:

### CHEMICAL WEATHERING

Another name for chemical weathering could be "rock dissolving". When rain falls it mixes with the carbon dioxide in the air to form a mild acid called **carbonic acid**. When this mildly acidic rainwater comes into contact with rock, some substances in the rock are dissolved by the water. The substance that dissolves most in acid is a mineral called calcite, which has the chemical formula  $\text{CaCO}_3$ . Where there is a lot of calcite in the rock, the whole rock is slowly broken down by what appears to be the most gentle of substances - water.

### MECHANICAL WEATHERING

Any physical process that helps to break down rock is called **mechanical weathering**. One of the main forms of mechanical weathering is called **frost shattering**. This happens when water seeps into the cracks of a rock and expands upon freezing. The ice acts like a small but powerful wedge, and can split a rock into smaller pieces. The pressure from growing tree roots can also act as a wedge. Changes in a rock's temperature (i.e., heating by sunshine, then cooling by rain or snow) causes cracks to grow as the rock expands or contracts. This is also a form of mechanical weathering.

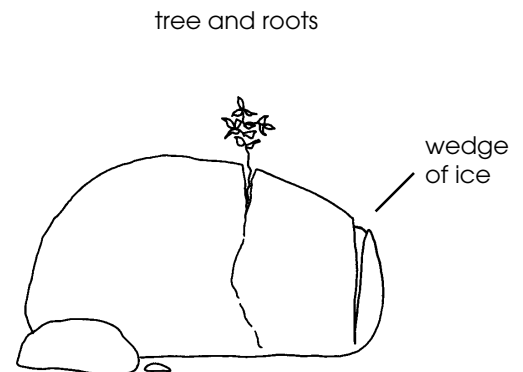

Wedges formed by ice and roots

## WATER EROSION

In its various forms, water carries most of the rock back to the sea. Rivers and creeks cut into mountainsides, creating deep V-shaped valleys like the ones seen in the mountains surrounding the Upper Kananaskis Lake. Rain pounds into the sides of mountains, carrying away loosened sediment and rock as it runs down the mountainside.

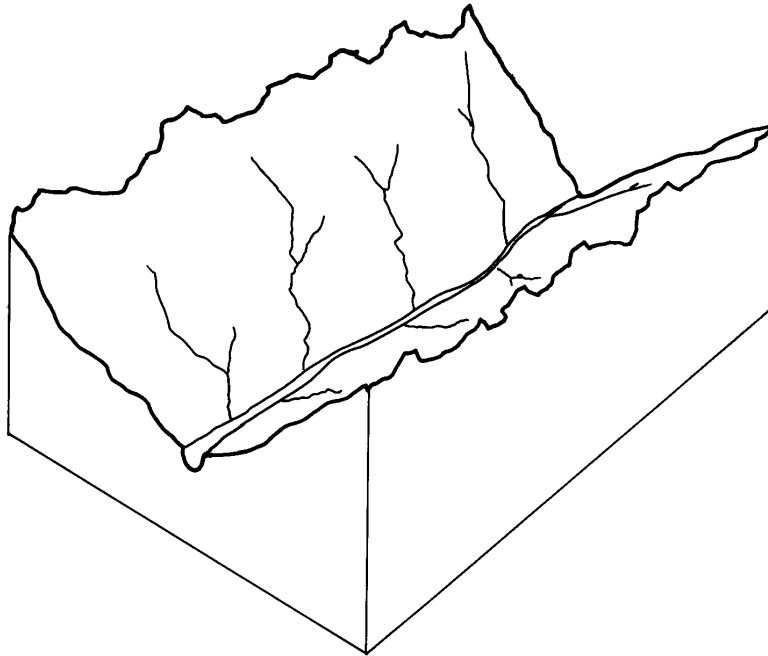

**Water Erosion**

## WIND EROSION

As wind blows, it can pick up hard grains of rock sediment and blow them into exposed rock outcroppings. Like a sandblaster, these hard grains can wear away softer types of rock.

## GLACIAL EROSION

The most important erosional force in the Rockies was - and in some locations, still is - ice in the form of glaciers. For almost two million years this major erosional force visited and revisited North America. In fact, ice once covered areas in Kananaskis Country to heights of 600 to 1000 metres!

Where conditions are cold enough to prevent snowfalls from melting during the summers, the snow begins to accumulate. As the weight of the overlying snows increases, the snow compacts and eventually turns into massive ice sheets. The ice sheets are called **glaciers**, and are so heavy that they tend to flow downhill. As they flow, they picked up large rock fragments which act as grinding tools to carve and scrape the rock surface beneath them.

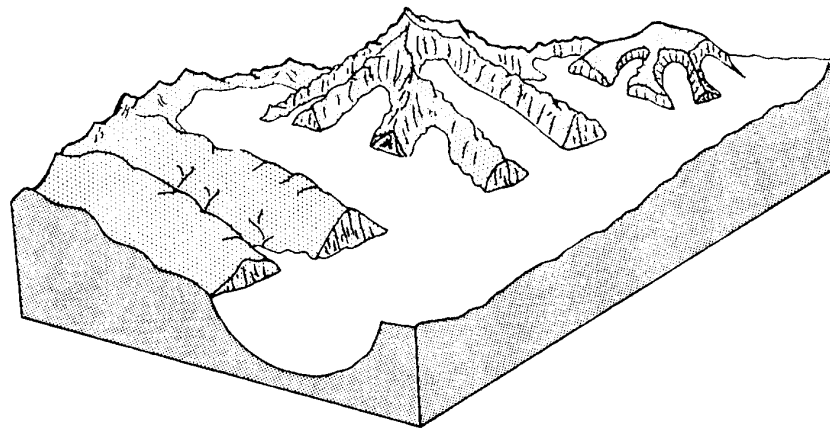

### Glaciated Landscape

Glaciers are still present in some areas of Kananaskis Country, and are seen at Stop #4 of the field study. But they were much larger and more abundant during the last ice age when, working like giant pieces of sandpaper, the glaciers reshaped the “Blocky Mountains” into the peaks and scenic valleys of the “Rocky Mountains” that we see today.

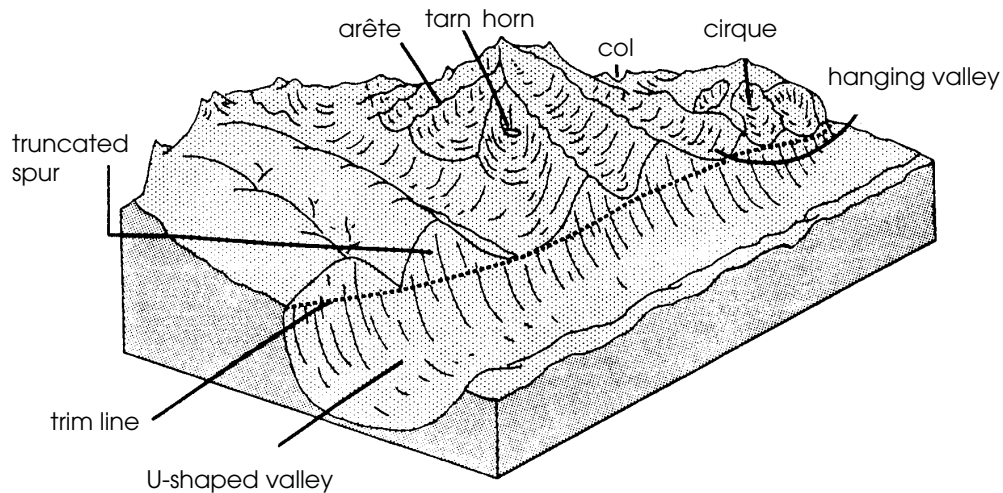

### Glaciated Landscape features

#### CONCLUSION

We have now come full circle in the story of the Rocky Mountains, from their birth in the sea to their eventual return.

By deciphering the rock records which reveal the many forces affecting the earth, we can gain an understanding of how the Earth has always been in a state of change, and of how the earth's "building materials" are constantly being used over and over again, resulting in the birth and death of whole mountain ranges. What happened to the Earth's crust in the past is happening now, and will probably happen long after humans have made his final mark on the planet.

## ACTIVITIES

### A) WATER EROSION

The main erosional force in Kananaskis Country these days is... water erosion.

1. Fill a transparent plastic cup with water from Boulton Creek. Try to get the best water sample you can find. Be careful not to disturb the stream bottom and stir up the bottom sediment.
2. Hold the sample of water up to the light and examine the water closely. Do you see any particles floating in the water? If you see nothing, try swirling the water slightly in the cup and try again. What do you see floating in the water?

---

---

---

3. Carefully pour several cups of water over the clay model you prepared at the last stop.
  - a) What do you notice about the surface of the model after the water has passed over it?
  - b) What do you think would happen if a stream of water were allowed to pass over your model continuously?

---

---

---

4. Take a closer look at Boulton Creek.
  - a) Where might the river sediment have come from?
  - b) Predict the effect the sediment load might have on the creek bank and bottom. (Hint: sand suspended in the water has the same effect on the river bank and bottom as sandpaper has on a piece of wood).
  - c) What would happen to the sediment carried by a river if the river were dammed?

---

---

---

### Cookie Activity

5. If you have wafered cookies, unwrap them - but no bites yet. Observe that the cookie is composed of different layers of edible materials. Choose a surface that shows this cookie layering (e.g., the edge of the cookie) and lick this surface fifty times. What do you observe about the erosion of the surface?

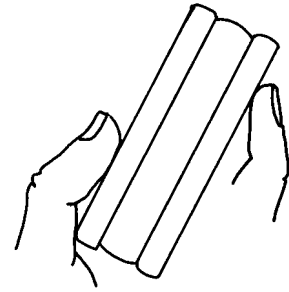

layered cookie

---

---

### **B) GLACIAL EROSION**

6. The diagram on the following page is a panorama of the scene that you see in front of you from the Lower Lakes Day Use Area. Arrows on this diagram point to various different landforms. Choose from among the following list of landform names to label your diagram.

horn                      arête                      cirque                      glacier  
U-shaped valley      anticline                      syncline

**CHALLENGE QUESTIONS**

1. Using the figure showing glacial landforms as a guide, match the names of the various glacial landforms to their definitions.

1. tarn
2. cirque
3. arête
4. hanging valley
5. horn
6. col
7. U-shaped valley

- a lake that is found in a glacier-carved depression
- a low point, or pass, in a mountain ridge
- a bowl-shaped depression that was carved by a glacier
- a sharp peak that is formed when several cirques join at the top
- a knife-like ridge that separates two cirques
- a small, glacial valley that is suspended above the floor of a main valley
- a valley that has been carved from a V-shaped into a U-shape by a glacier



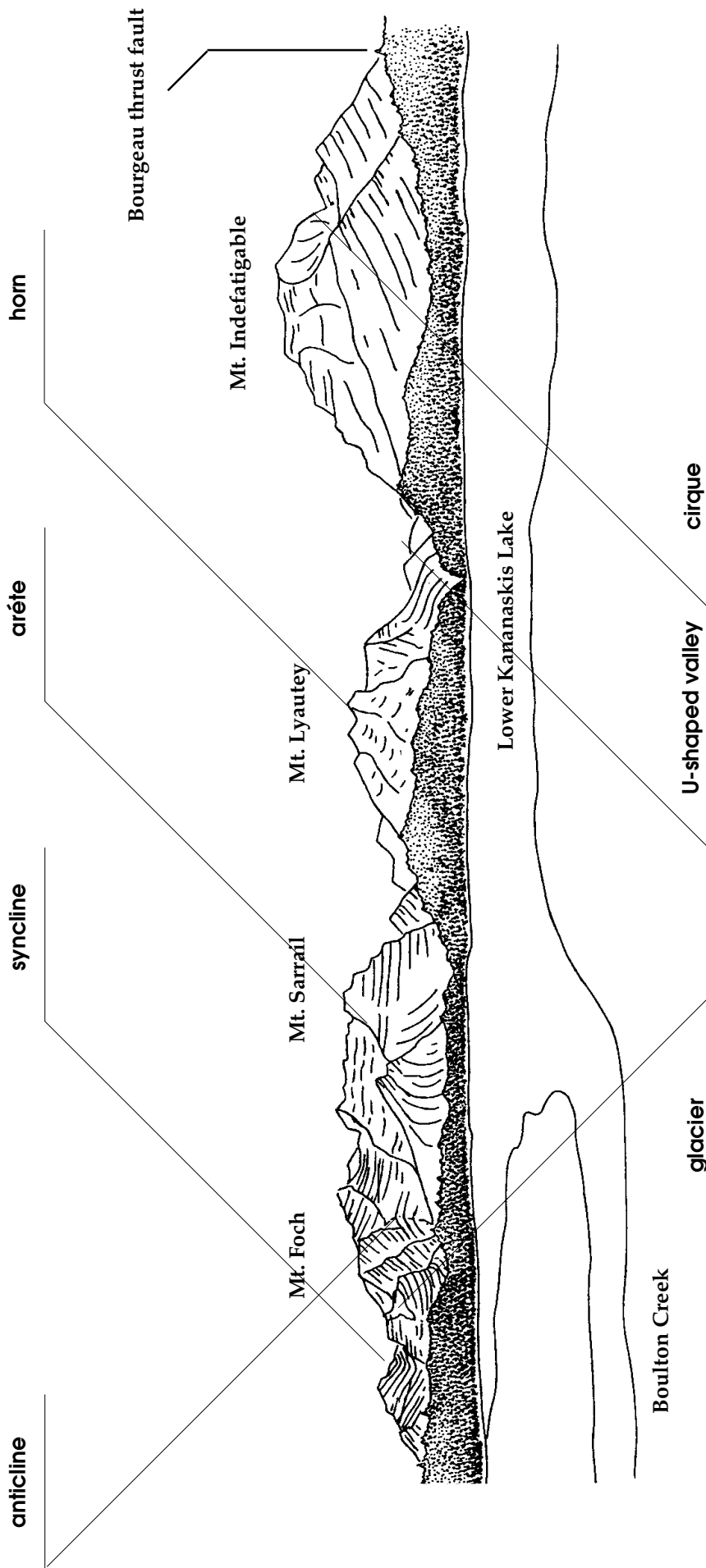

**Notes:**

The Borgeau thrust fault separates Devonian Rock (370 million years old) from Jurassic rock (104 million years old). A difference of 200 million years is seen along the thrust fault line.

In general, the higher, steeper rock faces that are seen in this panorama are limestones and dolomites; the lower, gentler, grass- and tree -covered slopes are sandstones and shales.

The primary erosional force that shaped this area is glaciation.

# GLOSSARY OF TERMS

arête	knife-edged ridge between two cirques
anticline	an arch-shaped rock fold (opposite of a syncline)
bed	a single sedimentary layer (e.g., a sandstone or shale bed)
bedding plane	the surface between two beds
calcium carbonate	chemical name for the mineral calcite. The rock called limestone is composed of 100% calcite.
carbonic acid	a naturally occurring acid that forms when water is mixed with the carbon dioxide in the air.
chemical weathering	the chemical process that dissolves rock.
cirque	a bowl-shaped hollow in a mountainside caused by the digging action of a glacier
col	a low spot or "pass" on a mountain ridge; may mark the intersection of two valleys
delta	a fan-shaped body of sediments deposited in a lake or ocean at the mouth of a river.
drumlin	a tapered hill made of clay and rocks that is formed by a glacier.
erosion	the processes by which soil and rock particles are broken up and carried away by water, ice or wind.
glacier	a large, permanent collection of snow and ice that flows downhill at a slow rate (i.e. a few metres per year)
horn	a pointed mountain peak created by the formation of cirques on two or more sides of the mountain
hanging valley	a U shaped valley that intersects another valley, not at the bottom of the larger valley but part way up the valley wall
igneous rock	rock created by the cooling of molten magma
isostasy	the floating of the earth's solid crust upon the liquid mantle.

isostatic rebound	the upward movement of the earth's crust after a downward pressure has been removed.
lithification	the process that causes sediment to become rock.
mechanical weathering	the physical processes that break down rock.
metamorphic rock	rock formed from pre-existing rock by strong heat or pressure.
sediment	rock fragments of various sizes that have been deposited in a river, lake or ocean.
sedimentary rock	rock that consists of sediments bound together by some substance that acts as a cement
stratification	parallel layers or beds of sedimentary rock (the pages of a book can be said to be stratified).
subduction	a process that may occurs where continental plates meet, consisting of one plate (usually a continental plate) overriding a more dense plate (usually an oceanic plate)
syncline	a U-shaped rock fold (opposite to an anticline).
tarn	a lake that forms in the bottom of a cirque
U-shaped valley	a valley carved by a glacier
V-shaped valley	a valley carved by a stream or river
weathering	the process by which rocks are broken down by natural forces such as wind, water, and ice.